



**GIRRAWEEN HIGH SCHOOL  
MATHEMATICS EXTENSION 2**

**TASK 1 2015 December 2014: COMPLEX NUMBERS**

**ANSWERS COVER SHEET**

Name: \_\_\_\_\_

Teacher: \_\_\_\_\_

FINAL MARK
---------------

	MARK	E2	E3	E4	E5	E6	E7	E8
1-5 Multiple Choice	/5		√					
6	/17		√					
	/17							
7	/14		√					
	/14							
8	/15		√					
	/15							
9	/13		√					
	/13							
10	/8		√					
	/8							
11	/13		√					
	13							
<b>TOTAL</b>	<b>/85</b>		<b>/85</b>					

## HSC Outcomes

## Mathematics Extension 2

- E1 appreciates the creativity, power and usefulness of mathematics to solve a broad range of problems.
- E2 chooses appropriate strategies to construct arguments and proofs in both concrete and abstract settings.
- E3 uses the relationship between algebraic and geometric representations of complex numbers and of conic sections.
- E4 uses efficient techniques for the algebraic manipulation required in dealing with questions such as those involving conic sections and polynomials.
- E5 uses ideas and techniques from calculus to solve problems in mechanics involving resolution of forces, resisted motion and circular motion
- E6 combines the ideas of algebra and calculus to determine the important features of the graphs of a wide variety of functions.
- E7 uses the techniques of slicing and cylindrical shells to determine volumes.
- E8 applies further techniques of integration, including partial fractions, integration by parts and recurrence formulae, to problems.
- E9 communicates abstract ideas and relationships using appropriate notation and logical argument.



**GIRRAWEEN HIGH SCHOOL**

**TASK 1 2015 (December 2014)**

**MATHEMATICS**

**EXTENSION 2**

**Complex Numbers**

*Time allowed – 100 Minutes*

**DIRECTIONS TO CANDIDATES**

- Attempt ALL questions.
- All necessary working should be shown in every question. Marks may be deducted for careless or badly arranged work.
- Board-approved calculators may be used.
- For Questions 6 -11: Each question attempted is to be returned on a *separate* piece of paper clearly marked Question 1 , Question 2 , etc. Each piece of paper must show your name.
- You may ask for extra pieces of paper if you need them.
- For Multiple Choice questions: colour in the oval corresponding to the correct answer on Multiple Choice answer sheet.
- Diagrams are NOT TO SCALE.

Year 11 Term 4 Examination – Mathematics Extension 2 2014

(Complex Numbers)

Multiple Choice Answer Sheet

Student Name: \_\_\_\_\_

Teacher: \_\_\_\_\_

Select the alternative A, B, C or D that best answers the question. Fill in the response oval completely.

**Sample:**  $2 + 4 =$  (A) 2 (B) 6 (C) 8 (D) 9  
 A  B  C  D

If you think you have made a mistake, put a cross through the incorrect answer and fill in the new answer.

A  B  C  D

If you change your mind and have crossed out what you consider to be the correct answer, then indicate the correct answer by writing the word *correct* and drawing an arrow as follows.

A  B  C  D   
 correct

---

1.	A	<input type="radio"/>	B	<input type="radio"/>	C	<input type="radio"/>	D	<input type="radio"/>
2.	A	<input type="radio"/>	B	<input type="radio"/>	C	<input type="radio"/>	D	<input type="radio"/>
3.	A	<input type="radio"/>	B	<input type="radio"/>	C	<input type="radio"/>	D	<input type="radio"/>
4.	A	<input type="radio"/>	B	<input type="radio"/>	C	<input type="radio"/>	D	<input type="radio"/>
5.	A	<input type="radio"/>	B	<input type="radio"/>	C	<input type="radio"/>	D	<input type="radio"/>

---

Questions 1-5 Multiple Choice: Colour in the correct answer on your multiple choice answer sheet:

(1) The value of  $(-i)^{11}$  is:

- (A)  $-i$                       (B)  $-1$                       (C)  $i$                       (D)  $1$

(2) If  $z = 3 - 2i$  and  $w = 1 + 3i$  then  $\bar{z}w =$

- (A)  $-3 + 7i$                       (B)  $-3 + 11i$                       (C)  $9 + 7i$                       (D)  $9 + 11i$

(3) When expressed in modulus/ argument form  $4\sqrt{3}(\cos(-\frac{\pi}{6}) + i\sin(-\frac{\pi}{6})) =$

- (A)  $6 + i\sqrt{3}$                       (B)  $3 - i\sqrt{3}$                       (C)  $-6 + i\sqrt{3}$                       (D)  $6 - 2i\sqrt{3}$

(4) The region in the complex plane defined by  $|z + 1| < 3$  and  $\frac{\pi}{4} \leq \text{Arg}(z + 1) \leq \frac{\pi}{2}$  is represented by:

(A)

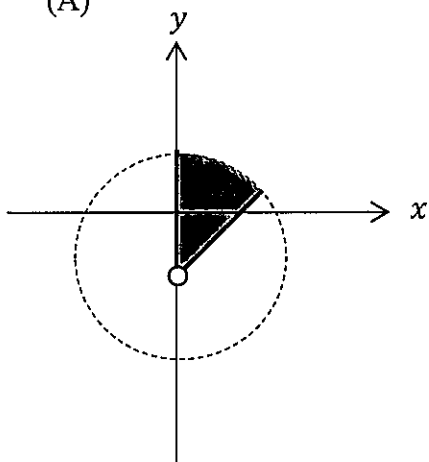

(B)

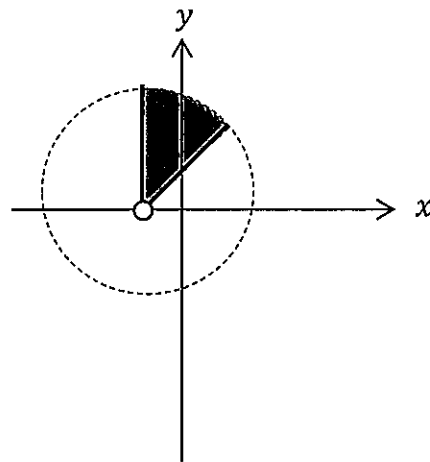

(C)

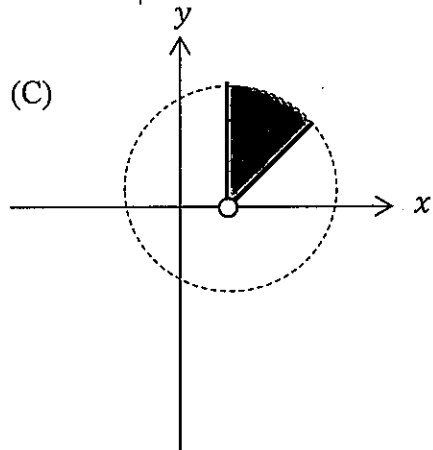

(D)

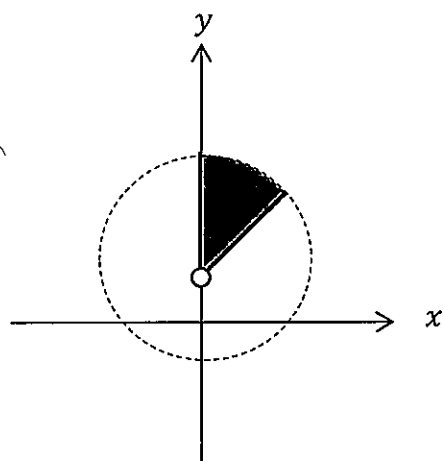

(5) In Cartesian form,  $\frac{39+26i}{2-3i} =$

- (A)  $13i$                       (B)  $12-5i$                       (C)  $12+5i$                       (D)  $-13i$

For Question 6 onward show all workings on the blank paper provided:

Question 6 (17 Marks)	Marks
(a) (i) Find $\frac{\sqrt{3}-i}{1-i}$ in cartesian form.	2
(ii) Convert $\sqrt{3} - i$ and $1 - i$ to modulus/ argument form.	2
(iii) Use the answers to (i) and (ii) to find the exact value of $\sin \frac{\pi}{12}$ .	2
(b) (i) If $x + iy = \sqrt{-7 + 24i}$ , $x, y, real$ find the value of $x$ and $y$ .	4
(ii) Hence solve the quadratic equation $z^2 + (-1 + 2i)z + (1 - 7i) = 0$ .	2
(c) Use DeMoivre's Theorem to find $(\sqrt{3} - i)^7$ in Cartesian form.	3
(d) Find the five fifth roots of $-16\sqrt{3} + 16i$ . Leave your answers in modulus/argument form.	2

**Question 7 (14 Marks)**

- (a) Sketch the following loci on separate Argand diagrams:
- (i)  $|z - i| = 3$  2
  - (ii)  $Arg(z - 1 + 2i) = \frac{\pi}{6}$ . 2
  - (iii)  $|z + 2 + 3i| = |z + i|$  3
  - (iv)  $z\bar{z} = 4Im(z)$  3
- (b) Sketch and shade the region on the number plane satisfied by both  $-1 \leq Re(z) \leq 1$  and  $\frac{-\pi}{4} < Arg(z + 2) \leq \frac{\pi}{4}$ . 4

**Examination continues on the next page**

**Question 8 (15 Marks)**

**Marks**

- (a)  $z$  and  $w$  are arbitrary points on the complex plane such that  $\overrightarrow{OA} = z$  and  $\overrightarrow{OB} = w$ . (See below)

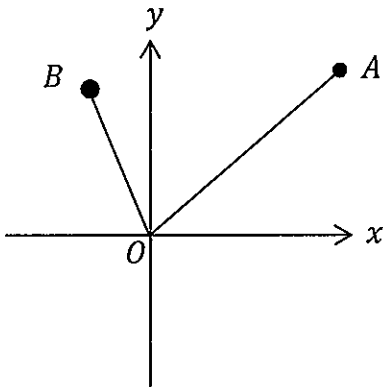

Copy the diagram on to your writing paper and draw in

- (i)  $\overrightarrow{OC}$  so that  $\overrightarrow{OC} = -iz$  1
  - (ii)  $\overrightarrow{OD}$  so that  $\overrightarrow{OD} = z \times (\cos \frac{\pi}{4} + i \sin \frac{\pi}{4})$  1
  - (iii)  $\overrightarrow{OE}$  so that  $\overrightarrow{OE} = z + w$  1
  - (iv)  $\overrightarrow{OF}$  so that  $\overrightarrow{OF} = z - w$  1
- (b) In the diagram below,  $\overrightarrow{OA} = z_1$ ,  $\overrightarrow{OB} = z_2$  and  $\overrightarrow{OC} = z_3$ .  $AB$  and  $AC$  are tangents to the circle  $OAC$ , centre  $O$ .

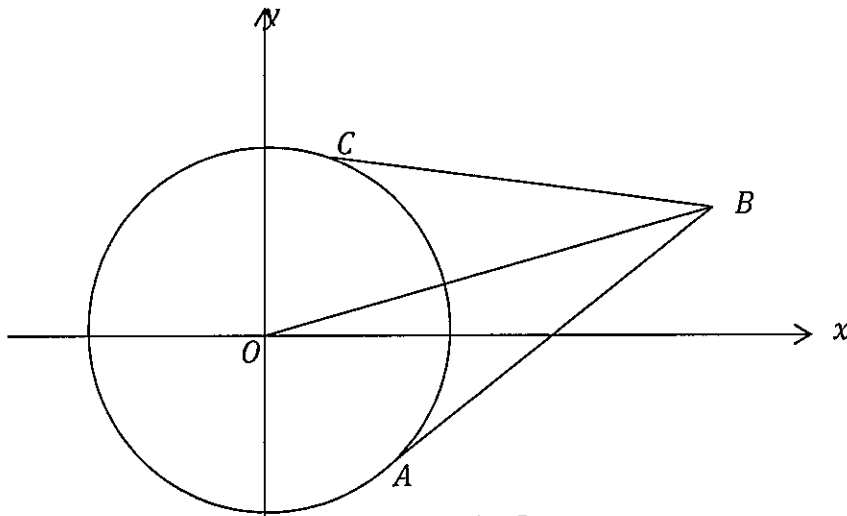

- (i) State why  $\frac{z_3 - z_2}{z_3}$  and  $\frac{z_2 - z_1}{z_1}$  are entirely imaginary. 3
- (ii) State why  $|z_3 - z_2| = |z_2 - z_1|$  2
- (iii) Prove  $\frac{z_3 - z_1}{z_2}$  is entirely imaginary. 4
- (iv) Find, with reasons, the centre of the circle  $OACB$ . 2

**Examination continues on the next page**

**Question 9 (13 Marks)****Marks**

- (a) The graph of  $\text{Arg} \left( \frac{z+4}{z-2} \right) = \frac{2\pi}{3}$  represents part of a circle. Draw this circle part and find its centre, radius and Cartesian equation. **4**
- (b) (i) If  $z = \cos\theta + i\sin\theta$ , prove that  $z^n + \frac{1}{z^n} = 2\cos n\theta$ . **3**
- (ii) Solve  $z^8 + 1 = 0$  and use your solutions to resolve  $z^8 + 1$  into real quadratic factors. **3**
- (iii) Use your answers to (i) and (ii) to prove **3**
- $$\cos 4\theta = 8(\cos^2\theta - \cos^2\frac{\pi}{8})(\cos^2\theta - \cos^2\frac{3\pi}{8}).$$

**Question 10 (8 Marks)**

- (a) Use DeMoivre's Theorem to find formulae for
- (i)  $\sin 7\theta$  **2**
- (ii)  $\cos 7\theta$  **1**
- (You may leave your answers in terms of mixed  $\sin\theta$  and  $\cos\theta$ .)*
- (b) Use your answers to (a) to derive the formula for  $\tan 7\theta$  in terms of  $\tan\theta$ . **2**
- (c) Using your answers to (a) and (b) or otherwise, show that  $i\tan\frac{\pi}{7}$  is a **3**
- solution to the equation  $x^6 + 21x^4 + 35x^2 + 7 = 0$ .
- (Do not solve this equation.)*

**Examination continues on the next page**



**Question 11 (13 Marks)**

**Marks**

(a) Solve  $z^9 - 1 = 0$ .

**1**

(b) If  $w$  is the root of  $z^9 - 1 = 0$  with the smallest positive argument,

**1**

show that  $w^2, w^3, w^4, w^5, w^6, w^7$  and  $w^8$  are the other non real roots of this equation.

(c) On the diagram below,

$\overrightarrow{OA} = w, \overrightarrow{OB} = w^2, \overrightarrow{OC} = w^3, \overrightarrow{OD} = w^4, \overrightarrow{OE} = w^5, \overrightarrow{OF} = w^6,$   
 $\overrightarrow{OG} = w^7, \overrightarrow{OH} = w^8$  and  $\overrightarrow{OI} = 1$ .

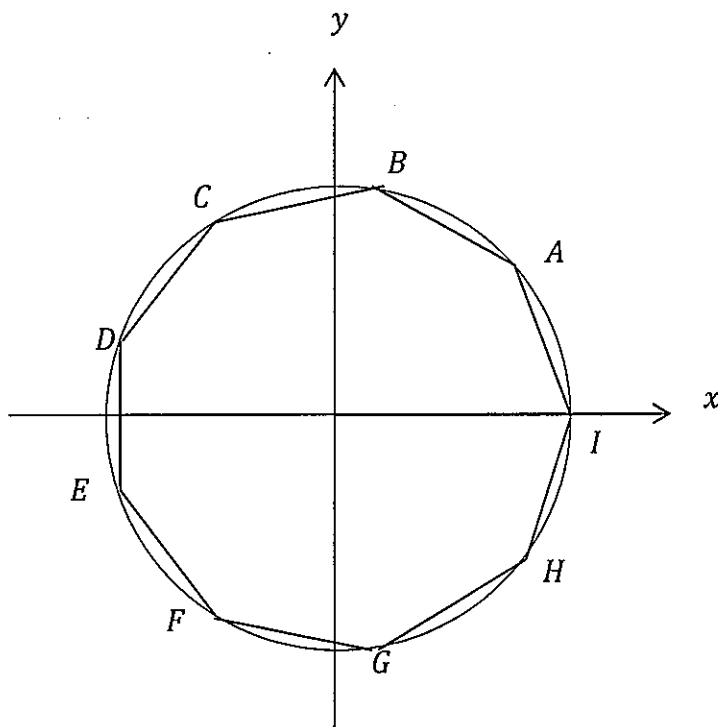

(i) Find the area of the regular nonagon formed by joining  $A, B, C, D, E, F, G, H$  and  $I$ . (Answer to 2 decimal places.)

**2**

(ii) Prove  $\text{Arg} \left\{ \frac{w-w^6}{w^8-w^5} \right\} = \frac{\pi}{3}$ .

**3**

(d) (i) Show that  $1 + w + w^2 + w^3 + w^4 + w^5 + w^6 + w^7 + w^8 = 0$ .

**1**

(ii) Hence or otherwise show that

$$(w^4 + w^5)(w^2 + w^7) + (w^3 + w^6)(w^2 + w^7) = -1.$$

**2**

(iii) Hence or otherwise show that  $\cos \frac{4\pi}{9} \left\{ 2\cos \frac{8\pi}{9} - 1 \right\} = -\frac{1}{2}$ .

**3**

**Here endeth the examination!!!**

Year 11 Term 4 Examination – Mathematics Extension 2 2014

(Complex Numbers)

Multiple Choice Answer Sheet

P.1

Student Name: Solutions

Teacher: Hudley

Select the alternative A, B, C or D that best answers the question. Fill in the response oval completely.

Sample:  $2 + 4 =$  (A) 2 (B) 6 (C) 8 (D) 9  
 A  B  C  D

If you think you have made a mistake, put a cross through the incorrect answer and fill in the new answer.

A  B  C  D

If you change your mind and have crossed out what you consider to be the correct answer, then indicate the correct answer by writing the word *correct* and drawing an arrow as follows.

A  B  C  D   
 correct

1.	A	<input type="radio"/>	B	<input type="radio"/>	C	<input checked="" type="radio"/>	D	<input type="radio"/>
2.	A	<input type="radio"/>	B	<input checked="" type="radio"/>	C	<input type="radio"/>	D	<input type="radio"/>
3.	A	<input type="radio"/>	B	<input type="radio"/>	C	<input type="radio"/>	D	<input checked="" type="radio"/>
4.	A	<input type="radio"/>	B	<input checked="" type="radio"/>	C	<input type="radio"/>	D	<input type="radio"/>
5.	A	<input checked="" type="radio"/>	B	<input type="radio"/>	C	<input type="radio"/>	D	<input type="radio"/>

p.1 Year 11 Extension 2 Complex Numbers

Task 1 2015 [December 2014]

— Solutions:—

$$(1) \quad C \quad (-i)^{11} = (-i)^8 \times (-i)^2 \times (-i) = 1 \times -1 \times -i = i$$

$$(2) \quad B \quad \bar{z}w \\ = (3+2i)(1+3i) \\ = -3+11i$$

$$(3) \quad D \quad 4\sqrt{3} \left( \cos \frac{-\pi}{6} + i \sin \frac{-\pi}{6} \right) \\ = 4\sqrt{3} \left( \frac{\sqrt{3}}{2} - \frac{1i}{2} \right) \\ = 6 - 2i\sqrt{3}$$

(4) B

$$(5) \quad A \quad \frac{39+26i}{2-3i} \times \frac{(2+3i)}{(2+3i)}$$

$$= \frac{78+117i+52i-78}{13}$$

$$= 13i$$

p. 2<sup>nd</sup> Y11 Extension 2 Complex Numbers Solutions

$$Q. (b)(a)(i) \frac{\sqrt{3} - i}{1 - i} \times \frac{(1+i)}{(1+i)}$$

$$= \frac{\sqrt{3} + i\sqrt{3} - i + 1}{2}$$

$$= \frac{(\sqrt{3}+1)}{2} + i \frac{(\sqrt{3}-1)}{2}$$

$$(ii) \sqrt{3} - i = 2 \left( \cos \frac{-\pi}{6} + i \sin \frac{-\pi}{6} \right)$$

$$1 - i = \sqrt{2} \left( \cos \frac{-\pi}{4} + i \sin \frac{-\pi}{4} \right)$$

$$(iii) \frac{\sqrt{3} - i}{1 - i} = \frac{2 \left( \cos \frac{-\pi}{6} + i \sin \frac{-\pi}{6} \right)}{\sqrt{2} \left( \cos \frac{-\pi}{4} + i \sin \frac{-\pi}{4} \right)}$$

$$= \sqrt{2} \left( \cos \frac{\pi}{12} + i \sin \frac{\pi}{12} \right)$$

Equating imaginary parts of (i) & (iii)

$$\sqrt{2} \sin \frac{\pi}{12} = \frac{\sqrt{3}-1}{2}$$

$$\therefore \sin \frac{\pi}{12} = \frac{\sqrt{3}-1}{2\sqrt{2}}$$

$$(b)(i) \text{ If } x+iy = \sqrt{-7+24i}$$

$$(x+iy)^2 = -7+24i$$

$$(x^2-y^2) + 2ixy = -7+24i$$

Equating reals,

$$x^2 - y^2 = -7 \quad (1)$$

Equating imaginaries

$$\Rightarrow 2xy = 24 \quad \rightarrow$$

$$\therefore y = \frac{12}{x} \quad (2)$$

Sub. (2) in (1):

$$x^2 - \frac{144}{x^2} = -7$$

$$x^4 - 144 = -7x^2$$

$$x^4 + 7x^2 - 144 = 0$$

$$(x^2+16)(x^2-9) = 0$$

$$\text{As } x \text{ is real, } x = \pm 3$$

$$\text{As } y = \frac{12}{x}, y = \pm 4$$

$$\sqrt{-7+24i}$$

$$= \pm (3+4i)$$

Dec. 2014 for 2015

$$Q. (6)(b)(ii) \quad z^2 + (-1+2i)z + (1-7i) = 0$$

$$z = \frac{-b \pm \sqrt{b^2 - 4ac}}{2a}$$

$$= \frac{(1-2i) \pm \sqrt{(-1+2i)^2 - 4 \times 1 \times (1-7i)}}{2 \times 1}$$

$$= \frac{(1-2i) \pm \sqrt{-7+24i}}{2}$$

$$= \frac{1-2i \pm (3+4i)}{2} \quad [\text{from (i)}]$$

$$z = 2+i \quad \text{or} \quad z = -1-3i$$

$$(c) \quad (\sqrt{3}-i)^7$$

$$= \left[ 2 \left( \cos^{-\frac{\pi}{6}} + i \sin^{-\frac{\pi}{6}} \right) \right]^7$$

$$= 128 \left[ \cos^{-\frac{7\pi}{6}} + i \sin^{-\frac{7\pi}{6}} \right]$$

$$= 128 \left[ \cos \frac{5\pi}{6} + i \sin \frac{5\pi}{6} \right]$$

$$= 128 \left[ -\frac{\sqrt{3}}{2} + \frac{1}{2}i \right]$$

$$= -64\sqrt{3} + 64i$$

$$(d) \quad -16\sqrt{3} + 16i$$

$$= 32 \left( \cos \frac{5\pi}{6} + i \sin \frac{5\pi}{6} \right)$$

$$\therefore 5^{\text{th}} \text{ roots of } -16\sqrt{3} + 16i \text{ are}$$

$$2 \operatorname{cis} \frac{\pi}{6} + \frac{2k\pi}{5}, \quad k=0, 1, 2, 3, 4$$

$$= 2 \left( \cos \frac{\pi}{6} + i \sin \frac{\pi}{6} \right), 2 \left( \cos \frac{17\pi}{30} + i \sin \frac{17\pi}{30} \right), 2 \left( \cos \frac{29\pi}{30} + i \sin \frac{29\pi}{30} \right),$$

$$2 \left( \cos \frac{41\pi}{30} + i \sin \frac{41\pi}{30} \right), 2 \left( \cos \frac{53\pi}{30} + i \sin \frac{53\pi}{30} \right)$$

Complex Numbers

Dec. 2014 for 2015

Q. (7) (a) (i)  $|z-i|=3$

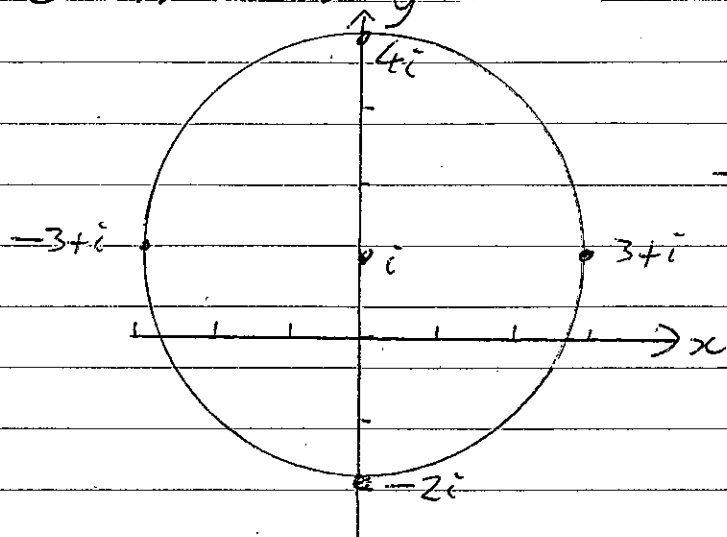

(ii)  $\text{Arg}(z-1+2i) = \frac{\pi}{6}$

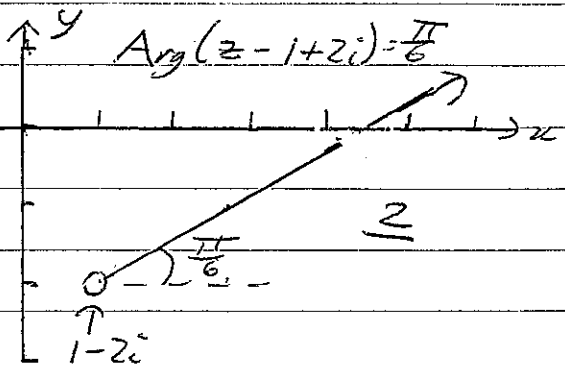

(iii)  $|z+2+3i| = |z+i|$

→ Will be perpendicular bisector of line between  $-2-3i$  &  $-i$ .

Using algebra,

$$\sqrt{(x+2)^2 + (y+3)^2} = \sqrt{x^2 + (y+1)^2}$$

$$y = -x - 3$$

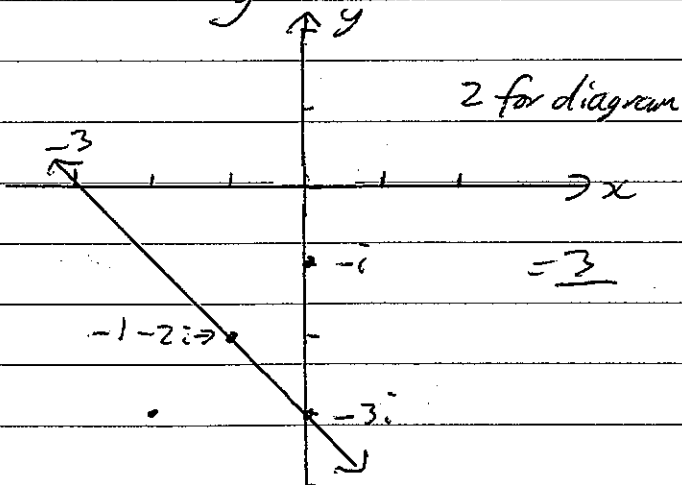

(iv)  $z\bar{z} = 4 \text{Im}(z)$

$$(x+iy)(x-iy) = 4y$$

$$x^2 + y^2 = 4y$$

Completing the square,

$$x^2 + (y^2 - 4y + 4) = 4$$

$$x^2 + (y-2)^2 = 4$$

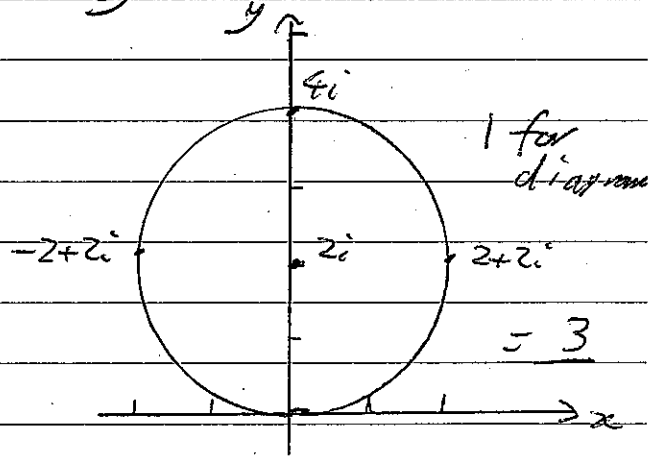

(b)

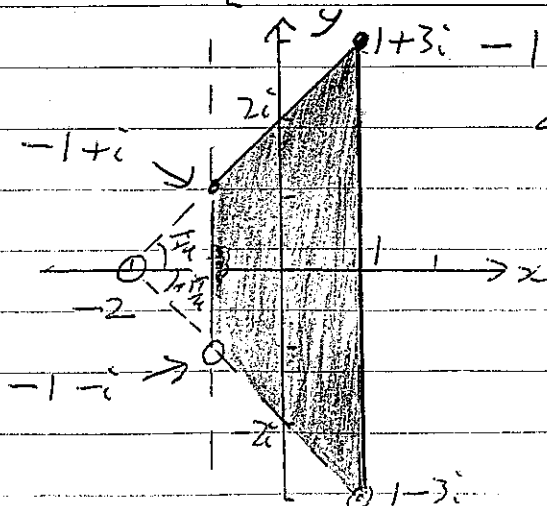

$-1 \leq \text{Re}(z) \leq 1$

&  $-\frac{\pi}{4} < \text{Arg}(z+2) \leq \frac{\pi}{4}$

- 1 for starting at  $-2$
- 1 for  $-1 \leq \text{Re } z \leq 1$ .
- 1 for  $-\frac{\pi}{4}$  to  $\frac{\pi}{4}$
- 1 for dotted & — lines.

4

Q. (8) (a)

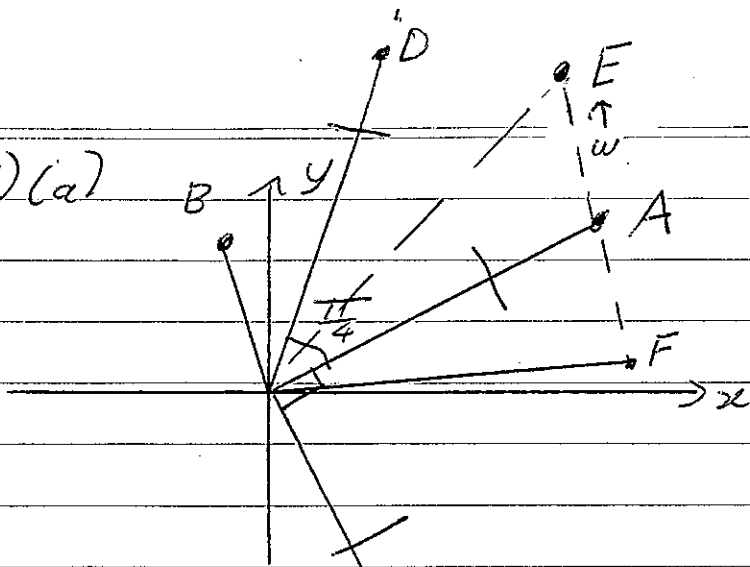

p. 5

4 (lead).

(b)

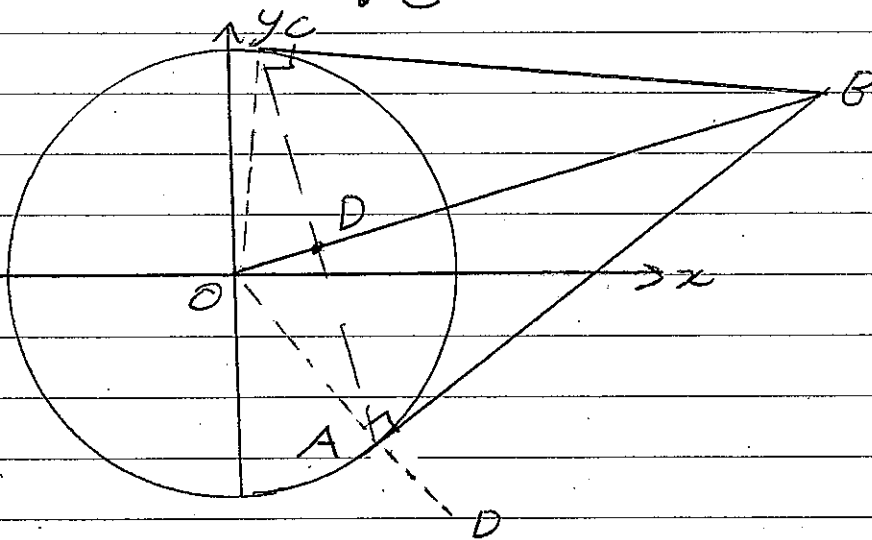

(i) Join OA, OC

$$\vec{AB} = z_2 - z_1$$

$$\vec{OA} = z_1$$

3

$\angle OAB = \frac{\pi}{2}$  [tangent  $\perp$  radius at point of contact]

$\therefore$  As  $\angle BAD = \frac{\pi}{2}$  [C's in straight line]

$$\angle BAD = \text{Arg} \left( \frac{z_2 - z_1}{z_1} \right)$$

$$\text{Arg} \left( \frac{z_2 - z_1}{z_1} \right) = \frac{\pi}{2} \text{ \& } \frac{z_2 - z_1}{z_1} \text{ is entirely imaginary.}$$

Similarly  $\vec{BC} = z_3 - z_2$

$$\vec{OC} = z_3$$

As  $\angle OCB = \frac{\pi}{2}$  [tangent  $\perp$  radius at point of contact].

$$\text{Arg} \left( \frac{z_3 - z_2}{z_2} \right) = \frac{3\pi}{2} \text{ [revolution]}$$

$z_3 - z_2$  is entirely imaginary.

$z_2$

$$Q.(8)(b)(ii) \text{ As } \vec{BC} = z_3 - z_2,$$

$$|BC| = |z_3 - z_2|.$$

$$\text{Similarly as } \vec{AB} = z_2 - z_1,$$

$$AB = |z_2 - z_1|$$

As  $BC = AB$  [tangents from external point =].

$$|z_3 - z_2| = |z_2 - z_1|.$$

$$(iii) \quad OC = OA \text{ [circle radii].}$$

$$BC = AB \text{ [proven above].}$$

$OABC$  is a kite [2 pairs of adjacent sides =].

Diagonals of kite  $OABC$  are  $\vec{AC} = z_3 - z_1$

$$\& \vec{OB} = z_2.$$

$\therefore$  Let  $D$  = point of intersection of  $OB$  &  $AC$

$$\angle CDB = \frac{\pi}{2} \text{ [diagonals of kite } \perp]$$

$$\text{As } \angle CDB = \text{Arg}\left(\frac{z_3 - z_1}{z_2}\right),$$

$$\text{Arg}\left(\frac{z_3 - z_1}{z_2}\right) = \frac{\pi}{2} \quad \frac{4}{4}$$

$\frac{z_3 - z_1}{z_2}$  is entirely imaginary.

(iv) As  $\angle OAB = \angle OCB = \frac{\pi}{2}$ ,  $OABC$  is a cyclic quadrilateral

&  $OB$  is circle diameter [in semicircle].

$\therefore$  Midpoint of  $OB$  is centre of circle  $OABC$ .



Q. (9)(a)  $\text{Arg}\left(\frac{z+4}{z-2}\right) = \frac{2\pi}{3}$

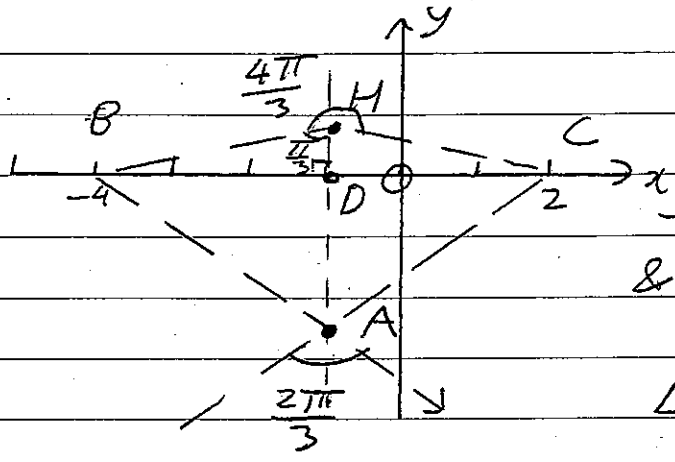

Notes: Centre of circle will be on  $x = -1$ .  
If  $\vec{OA} = 2$  below x axis

$-\frac{\pi}{2} < \text{Arg}(z+4) < 0$   
 $& -\pi < \text{Arg}(z-2) < -\frac{\pi}{2}$   
 $\vec{OA} = 2$   
 $\angle BAC = \frac{2\pi}{3}$  [Vertically opposite  $\angle$ s].

Let H = circle centre.

$\angle BHC$  [reflex] =  $\frac{4\pi}{3}$ , [L at centre =  $2x$   
 Lat circumference on same arc].

$\angle BHD = \frac{\pi}{3}$   
 $HD = \frac{3}{\tan \frac{\pi}{3}}$   
 $= \sqrt{3}$ .

∴ Circle centre =  $-1 + i\sqrt{3}$ .  
 Radius =  $HO = \sqrt{3^2 + (\sqrt{3})^2} = \sqrt{12} = 2\sqrt{3}$ .

Circle centre =  $-1 + i\sqrt{3}$ . Radius =  $2\sqrt{3}$ .  
 Equation is  $(x+1)^2 + (y-\sqrt{3})^2 = 12$ .

(b)(i)  $z = \cos \theta + i \sin \theta$ .

$z^n = \cos n\theta + i \sin n\theta$  [by De Moivre].

$\frac{1}{z^n} = z^{-n} = \cos(-n\theta) + i \sin(-n\theta)$  " "  
 $= \cos n\theta - i \sin n\theta$  [as cos is even & sin is odd].

∴  $z^n + \frac{1}{z^n} = (\cos n\theta + i \sin n\theta) + (\cos n\theta - i \sin n\theta)$   
 $\frac{z^n + 1}{z^n} = 2 \cos n\theta$ .

$$(9)(b)(i) z^8 + 1 = 0, z = \text{cis} \left( \frac{(2k+1)\pi}{8} \right), k = 0, 1, 2, \dots, 7. \quad |$$

$$z^8 + 1 = \left( z - \text{cis} \frac{\pi}{8} \right) \left( z - \text{cis} \frac{15\pi}{8} \right) \left( z - \text{cis} \frac{3\pi}{8} \right) \left( z - \text{cis} \frac{13\pi}{8} \right) \\ \left( z - \text{cis} \frac{5\pi}{8} \right) \left( z - \text{cis} \frac{11\pi}{8} \right) \left( z - \text{cis} \frac{7\pi}{8} \right) \left( z - \text{cis} \frac{9\pi}{8} \right) \quad |$$

$$z^8 + 1 = \left( z^2 - 2z \cos \frac{\pi}{8} + 1 \right) \left( z^2 - 2z \cos \frac{3\pi}{8} + 1 \right) \left( z^2 - 2z \cos \frac{5\pi}{8} + 1 \right) \left( z^2 - 2z \cos \frac{7\pi}{8} + 1 \right) \quad | \quad \underline{3}$$

(ii)

(iii) Dividing BS of (ii) by  $z^4$ :

$$z^4 + \frac{1}{z^4} = \left( z + \frac{1}{z} - 2 \cos \frac{\pi}{8} \right) \left( z + \frac{1}{z} - 2 \cos \frac{3\pi}{8} \right) \left( z + \frac{1}{z} - 2 \cos \frac{5\pi}{8} \right) \left( z + \frac{1}{z} - 2 \cos \frac{7\pi}{8} \right) \quad |$$

As  $z = \text{cis} \theta$ , using (i)  $z^n + \frac{1}{z^n} = 2 \cos n\theta$ ,

$$2 \cos 4\theta = \left( 2 \cos \theta - 2 \cos \frac{\pi}{8} \right) \left( 2 \cos \theta - 2 \cos \frac{3\pi}{8} \right) \left( 2 \cos \theta - 2 \cos \frac{5\pi}{8} \right) \left( 2 \cos \theta - 2 \cos \frac{7\pi}{8} \right) \quad |$$

Dividing BS by 2 & remembering  $\cos \frac{5\pi}{8} = -\cos \frac{3\pi}{8}$   
&  $\cos \frac{7\pi}{8} = -\cos \frac{\pi}{8}$

$$\cos 4\theta = 8 \left( \cos \theta - \cos \frac{\pi}{8} \right) \left( \cos \theta + \cos \frac{\pi}{8} \right) \left( \cos \theta - \cos \frac{3\pi}{8} \right) \left( \cos \theta + \cos \frac{3\pi}{8} \right) \quad |$$

$$\cos 4\theta = 8 \left( \cos^2 \theta - \cos^2 \frac{\pi}{8} \right) \left( \cos^2 \theta - \cos^2 \frac{3\pi}{8} \right) \quad | \quad \underline{3}$$

= RHS QED.

Q. (10) (a)  $\cos 7\theta + i \sin 7\theta = (\cos \theta + i \sin \theta)^7$

$$= \cos^7 \theta + 7i \cos^6 \theta \sin \theta - 21 \cos^5 \theta \sin^2 \theta - 35i \cos^4 \theta \sin^3 \theta + 35 \cos^3 \theta \sin^4 \theta + 21i \cos^2 \theta \sin^5 \theta - 7 \cos \theta \sin^6 \theta - i \sin^7 \theta$$

Equating imaginaries

(i)  $\sin 7\theta = 7 \cos^6 \theta \sin \theta - 35 \cos^4 \theta \sin^3 \theta + 21 \cos^2 \theta \sin^5 \theta - \sin^7 \theta$

(ii)  $\cos 7\theta = \cos^7 \theta - 21 \cos^5 \theta \sin^2 \theta + 35 \cos^3 \theta \sin^4 \theta - 7 \cos \theta \sin^6 \theta$

(b) Dividing (i) by (ii)

$$\tan 7\theta = \frac{7 \cos^6 \theta \sin \theta - 35 \cos^4 \theta \sin^3 \theta + 21 \cos^2 \theta \sin^5 \theta - \sin^7 \theta}{\cos^7 \theta - 21 \cos^5 \theta \sin^2 \theta + 35 \cos^3 \theta \sin^4 \theta - 7 \cos \theta \sin^6 \theta}$$

Dividing numerator & denominator by  $\cos^7 \theta$

$$\tan 7\theta = \frac{7 \tan \theta - 35 \tan^3 \theta + 21 \tan^5 \theta - \tan^7 \theta}{1 - 21 \tan^2 \theta + 35 \tan^4 \theta - 7 \tan^6 \theta}$$

(c) If  $\theta = \frac{\pi}{7}$  then  $\tan 7\theta = \tan \pi = 0$

$$\therefore \tan \pi = 0 = \frac{7 \tan \frac{\pi}{7} - 35 \tan^3 \frac{\pi}{7} + 21 \tan^5 \frac{\pi}{7} - \tan^7 \frac{\pi}{7}}{1 - 21 \tan^2 \frac{\pi}{7} + 35 \tan^4 \frac{\pi}{7} - 7 \tan^6 \frac{\pi}{7}}$$

$\times 85$  by  $(1 - 21 \tan^2 \frac{\pi}{7} + 35 \tan^4 \frac{\pi}{7} - 7 \tan^6 \frac{\pi}{7})$

$$- \tan^7 \frac{\pi}{7} + 21 \tan^5 \frac{\pi}{7} - 35 \tan^3 \frac{\pi}{7} + 7 \tan \frac{\pi}{7} = 0$$

$$- \tan^6 \frac{\pi}{7} + 21 \tan^4 \frac{\pi}{7} - 35 \tan^2 \frac{\pi}{7} + 7 = 0 \quad (1)$$

Substituting  $i \tan \frac{\pi}{7}$  in  $x^6 + 21x^4 + 35x^2 + 7$

$$= - \tan^6 \frac{\pi}{7} + 21 \tan^4 \frac{\pi}{7} - 35 \tan^2 \frac{\pi}{7} + 7$$

$$= 0 \text{ [from (1)]}$$

$\therefore i \tan \frac{\pi}{7}$  is a solution to  $x^6 + 21x^4 + 35x^2 + 7 = 0$

Q. (11) (a)  $z^9 - 1 = 0$

$z = \text{cis } \frac{2k\pi}{9}, k = 0, 1, 2, \dots, 8$  |

(b)  $w = \text{cis } \frac{2\pi}{9}$

$w^2 = \text{cis } \frac{4\pi}{9} \Rightarrow (w^2)^9 = \text{cis } 8\pi = 1$

$w^3 = \text{cis } \frac{6\pi}{9} \Rightarrow (w^3)^9 = \text{cis } 6\pi = 1$

$w^4 = \text{cis } \frac{8\pi}{9} \Rightarrow (w^4)^9 = \text{cis } 8\pi = 1$

$w^5 = \text{cis } \frac{10\pi}{9} \Rightarrow (w^5)^9 = \text{cis } 10\pi = 1$  |

$w^6 = \text{cis } \frac{12\pi}{9} \Rightarrow (w^6)^9 = \text{cis } 12\pi = 1$

$w^7 = \text{cis } \frac{14\pi}{9} \Rightarrow (w^7)^9 = \text{cis } 14\pi = 1$

$w^8 = \text{cis } \frac{16\pi}{9} \Rightarrow (w^8)^9 = \text{cis } 16\pi = 1$

(c) (i) Area =  $9 \times \frac{1}{2} \times 1 \times 1 \times \sin \frac{2\pi}{9}$  |

= 2.89 square units. | 2

(ii)

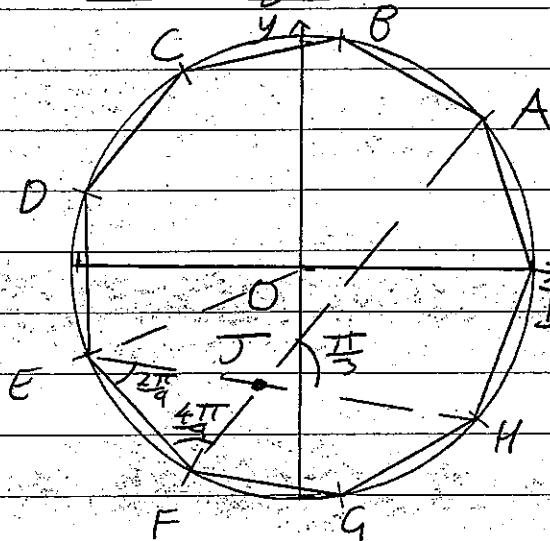

$\vec{FA} = w - w^6$

$\vec{EH} = w^8 - w^5$

Let intersection of AF & EH = J.

$\angle HEF = \frac{1}{2} \angle HOF$  [At circumference =  $\frac{1}{2}$  (at centre)]

=  $\frac{2\pi}{9}$

$\angle AFE = \frac{1}{2} \angle AOE$  [ " " ]  
=  $\frac{4\pi}{9}$

$\angle EHF = \frac{\pi}{3}$  [L sum  $\Delta EHF$ ]

$\angle AJH = \frac{\pi}{3}$  [Vertically opposite  $\angle$ s]

$\therefore \text{Arg} \left( \frac{w - w^6}{w^8 - w^5} \right) = \angle AJH = \frac{\pi}{3}$  | 3

p. 11

Q. (ii) (d) As  $1, \omega, \omega^2, \dots, \omega^8$  are roots of  $z^9 - 1 = 0$

By sum of roots,

$$1 + \omega + \omega^2 + \omega^3 + \omega^4 + \omega^5 + \omega^6 + \omega^7 + \omega^8 = 0. \quad \perp$$

$$\therefore \text{(i)} \quad (\omega^4 + \omega^5)(\omega^2 + \omega^7) + (\omega^3 + \omega^6)(\omega^2 + \omega^7)$$

$$= \omega^6 + \omega^{11} + \omega^7 + \omega^{12} + \omega^5 + \omega^{10} + \omega^8 + \omega^{13}$$

$$= \omega^6 + \omega^2 + \omega^7 + \omega^3 + \omega^5 + \omega + \omega^8 + \omega^4 \quad [\text{as } \omega^9 = 1]$$

$$= -1 \quad [\text{as } 1 + \omega + \dots + \omega^8 = 0]. \quad \perp \underline{\underline{2}}$$

$$\text{(ii) Using (a) } \omega^4 + \omega^5 = \cos \frac{8\pi}{9} + i \sin \frac{8\pi}{9} + \cos \frac{10\pi}{9} + i \sin \frac{10\pi}{9}$$

$$= \cos \frac{8\pi}{9} + i \sin \frac{8\pi}{9} + \cos \frac{8\pi}{9} - i \sin \frac{8\pi}{9}$$

$$= 2 \cos \frac{8\pi}{9}$$

$$\text{Similarly } \omega^2 + \omega^7 = 2 \cos \frac{4\pi}{9}$$

$$\omega^3 + \omega^6 = 2 \cos \frac{2\pi}{3} = -1$$

$$\therefore \text{ Using (a) } (\omega^4 + \omega^5)(\omega^2 + \omega^7) + (\omega^3 + \omega^6)(\omega^2 + \omega^7) = -1$$

$$2 \cos \frac{8\pi}{9} \times 2 \cos \frac{4\pi}{9} + (-1) \times 2 \cos \frac{4\pi}{9} = -1. \quad \perp$$

$$\div 2$$

$$2 \cos \frac{8\pi}{9} \cos \frac{4\pi}{9} - \cos \frac{4\pi}{9} = -\frac{1}{2} \quad \underline{\underline{3}}$$

$$\cos \frac{4\pi}{9} (2 \cos \frac{8\pi}{9} - 1) = -\frac{1}{2} \quad \perp$$

QED.

Here endeth the solutions!



# Mathematics Assessment Task Analysis

Task: Year 11 Extension 2 Mathematics Task 1 – COMPLEX NUMBERS December 2014

Question	Strengths	Challenges	Proposed teaching strategies to overcome challenges
6	Mostly very well done	<p>b (i) some students just found <math>x</math> &amp; <math>y</math> and did not express in the form <math>\sqrt{-7+24i} = \pm (3+4i)</math> <sup>no loss of marks</sup></p> <p>c) some students lost marks for not expressing answer in cartesian form as asked.</p>	<p>* stress the importance of reading questions carefully so marks are not lost unnecessarily.</p>
7	Question 7 was well done by most students	(a) (i) (ii) (iii) we often done algebraically when the sketches could be found easily by geometric means	Make your graphs are large and clear. Note the centre and radius of circles. Make it clear as to which areas are included or excluded.
8	<p>(a) Points C, D &amp; E generally well found.</p> <p>(b) <del>F</del> Most students realised tangent <math>\perp</math> radius in (i) &amp; Arg = <math>\frac{\pi}{2}</math> means entirely imaginary &amp; tangents = in (ii) &amp; L in semicircle &amp;</p>	<p>(a) F <math>\vec{OF} = z-w</math> not well done.</p> <p>(b) Arg <math>\left(\frac{z_1-z_2}{z_1}\right) = \frac{\pi}{2}</math> does not mean either <math>\frac{z_1-z_2}{z_1} = \frac{\pi}{2}</math> or <math>\frac{z_1-z_2}{z_2} = i</math> (it could be <math>2i</math> etc)</p> <p>Do geometry proofs PROPERLY and DRAW THE DIAGRAM!</p>	<p>* Be prepared to spend AT LEAST 4-5 lessons on Complex Numbers &amp; Vectors.</p> <p>→ An extra <del>at</del> in worksheet in my own teaching may be needed.</p> <p>* STRESS TO STUDENTS ALWAYS DRAW THE DIAGRAM!</p>

	Strengths	Challenges	Proposed teaching strategies
9	<p>(a) Most students realised angle at centre = <math>\frac{4\pi}{3}</math> &amp; centre is on <math>x = -1</math>.</p> <p>(b) Most students knew how to handle this problem well.</p>	<p>(a) Many students thought centre was BELOW x-axis. or made mistakes getting radius or FORGOT TO DRAW THE CIRCLE PART</p> <p>(b) The fussy bits: cos even, sin odd in (i) In (ii) explain how <math>\cos \frac{5\pi}{8} = -\cos \frac{3\pi}{8}</math>.</p>	<p>* More practice at graphing difficult loci which rely on vectors</p> <p>* Stress to students - don't leave anything out! Give reasons for EVERYTHING!</p>
10	<p>Part (a) and part (b) were really well done.</p>	<p>Part (c) caused a lot of difficulty. student tried to sub item (i) into (b) instead of <math>\theta = \frac{\pi}{7}</math>. Most failed to see the connection between (b) and (c)</p>	<p>Questions of this type are fairly common. Find them and study the solutions very carefully.</p>
11	<p>(a) (i) (d) (i) &amp; (ii) done quite well.</p>	<p>(c) (ii) created a lot of problems for majority of students.</p>	<p>* More questions on vectors in class [of more difficult type]. for (c) (ii)</p>