

Sydney Girls High School



MATHEMATICS EXTENSION 2

HSC Assessment Task 1
November 2012

Time Allowed - 60 minutes + 5 minutes reading time

Topics: Circular Motion , Curve Sketching

General Instructions:

- There are FOUR (4) Questions which are NOT of equal value.
- Attempt all questions.
- Show all necessary working. Marks may be deducted for badly arranged work or incomplete working.
- Start each question on a new page.
- Write on one side of the paper only.
- Diagrams are NOT to scale.
- Board-approved calculators may be used.
- Write your student number clearly at the top of each question and clearly number each question.
- Use $g = 10 \text{ ms}^{-2}$

Total: 50 marks

QUESTION 1 (13 Marks)

MARKS

(a) If $f(x) = 4x - x^3$, sketch :

(i) $y = f(x)$ 2

(ii) $y = [f(x)]^2$ 2

(iii) $y^2 = f(x)$ 3

(b) A mass of 4 kg is revolving at the end of a string 3 m long on a smooth horizontal table. The string will break when the speed of rotation reaches 12 rad/s.

(i) Find the breaking strain of the string. 2

(ii) Find the new maximum speed in rad/s if the 4 kg mass at the end of the string is replaced by a 3 kg mass and an additional 1 kg mass is added to the string, 2 metres from the 3 kg mass as shown in the diagram below. 4

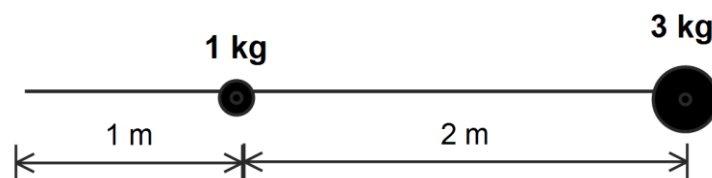

QUESTION 2 (12 Marks)

MARKS

- (a) Sketch $9x^2 + y^2 = 16$ showing important features. 2
- (b) The diagram below is a sketch of the function $y = f(x)$.

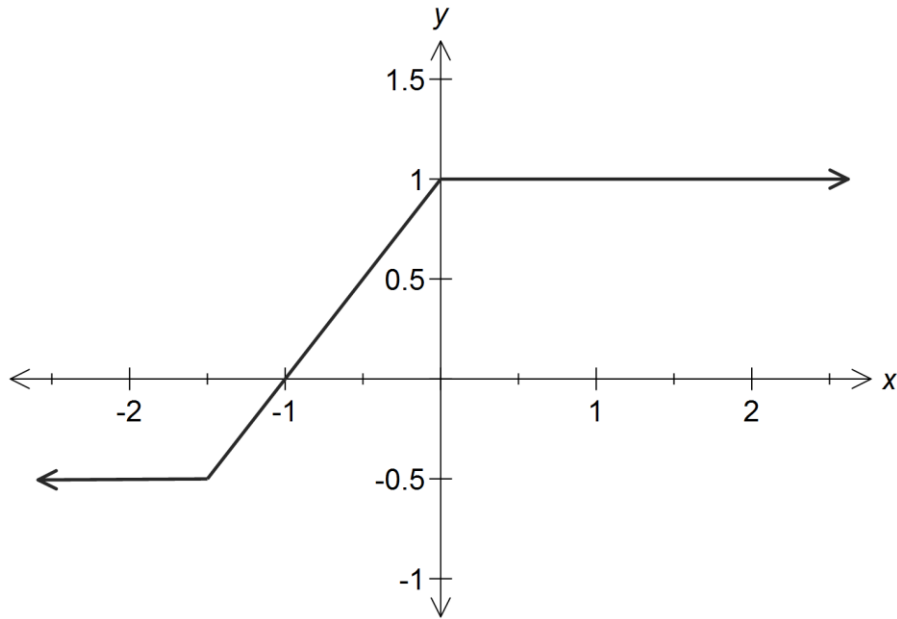

On separate diagrams, sketch :

- (i) $y = f(-x)$ 1
- (ii) $y = \frac{1}{f(x)}$ 2
- (iii) $y = 2^{f(x)}$ 2
- (iv) $|y| = f(x+1)$ 3
- (v) $y = x \times f(x)$ 2

QUESTION 3 (12 Marks)

MARKS

- (a) A 2 metre string has a 2 kg mass placed at the centre and another unknown mass at the bottom as shown in the diagram.

If the 2 kg mass is to rotate at 4 radians per second and the angle between the strings and the vertical is 30° , find the magnitude of the unknown mass at the bottom of the system.
(Give your answer correct to 2 decimal places).

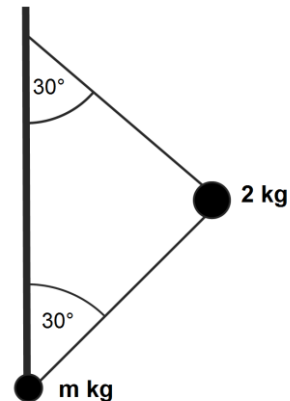

6

- (b) On a racetrack, a circular bend of radius 10 metres is banked at 45° to the horizontal. Given that the magnitude of the frictional force F (up or down the bank) is at most $\frac{1}{9}$ of the normal reaction N , find the maximum velocity (in exact form) at which a vehicle of mass m kilograms can safely negotiate the bend.

6

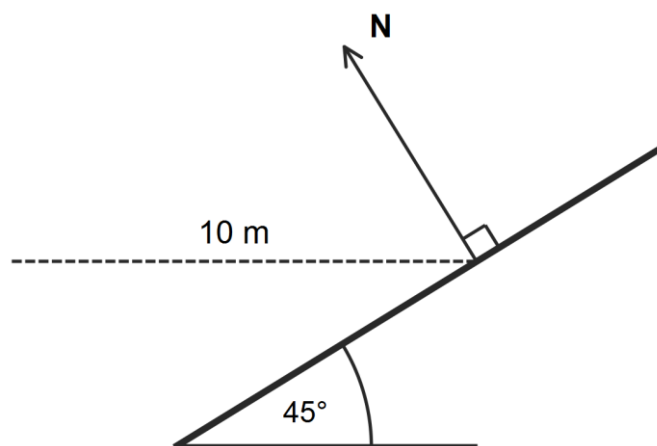

QUESTION 4 (13 Marks)

MARKS

- (a) Sketch (without using calculus) the following on separate number planes, showing important features including any intercepts and asymptotes :

(i) $y = \frac{2x}{(x+1)^2(3x-2)}$ 3

(ii) $y = \frac{x^2 - x}{x+1}$ 3

- (b) Two particles are connected by a light inextensible string which passes through a small hole with smooth edges in a smooth horizontal table. One particle of mass m travels on the table with constant angular velocity ω . Another particle of mass q travels in a circle with constant angular velocity R on a smooth horizontal floor, distance x below the table. The lengths of the string on the table and below the table are K and L respectively and the length L makes an angle θ with the vertical.

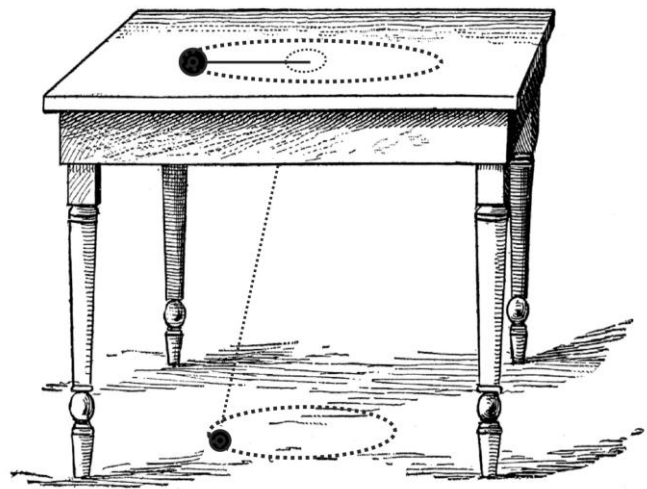

- (i) If the floor exerts a force N on the lower particle, show that $N = q(g - xR^2)$. 4
- (ii) Find the maximum possible value of R for the motion to continue as described. 1
- (iii) What happens if R exceeds this value? 1
- (iv) By considering the tension force in the string, show that $\frac{L}{K} = \frac{m}{q} \left(\frac{\omega}{R} \right)^2$. 1

$$1 (a) f(x) = x(4-x^2)$$

$$= x(2-x)(2+x)$$

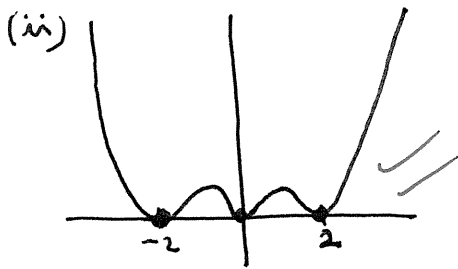
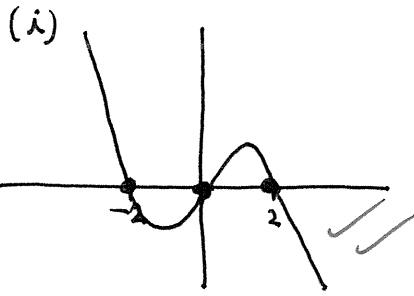

(iii) $y = \pm \sqrt{f(x)}$

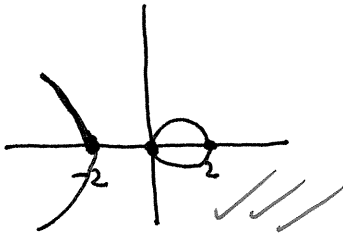

Solutions

MATHEMATICS EXTENSION 2

HSC Assessment Task 1

November 2012

(b) (i)

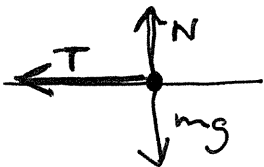

$$T = mr\omega^2$$

$$= 4 \times 3 \times 12^2$$

$$= 1728 \text{ N}$$

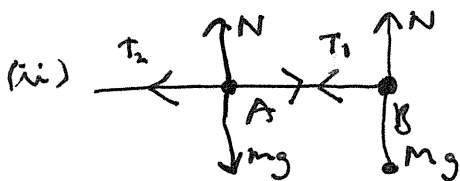

$$T_1 = mr\omega^2$$

$$= 3 \times (1+2) \times \omega^2$$

$$= 9\omega^2$$

$$T_2 = T_1 = mr\omega^2$$

$$T_2 = T_1 + 1 \times 1 \times \omega^2$$

$$= 9\omega^2 + 1\omega^2$$

$$= 10\omega^2$$

$$10\omega^2 = 1728$$

$$\omega^2 = 172.8$$

$$\omega = \sqrt{172.8}$$

$$= 13.1453... \text{ s}^{-1}$$

Question 2 (12 Marks)

a) $9x^2 + y^2 = 16$

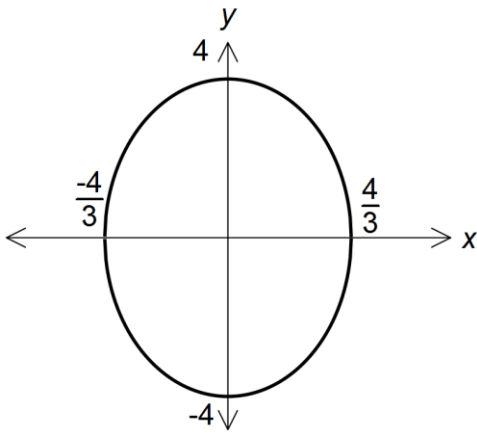

b) i) $y = f(-x)$

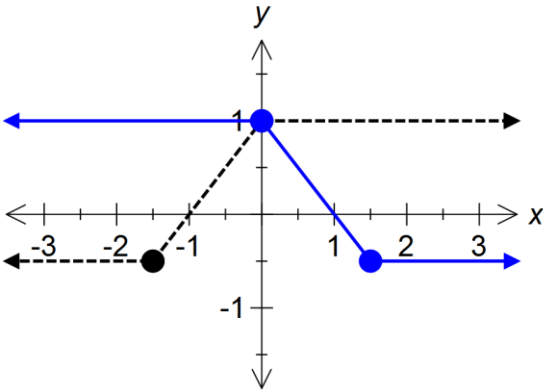

ii) $y = \frac{1}{f(x)}$

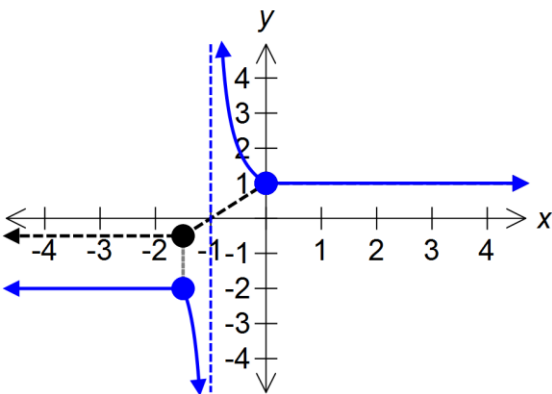

iii) $y = 2^{f(x)}$

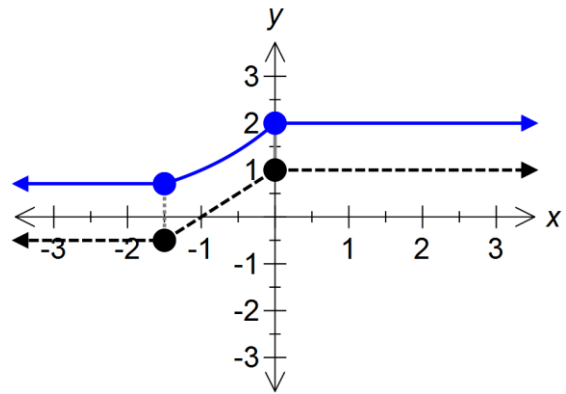

iv) $|y| = f(x+1)$

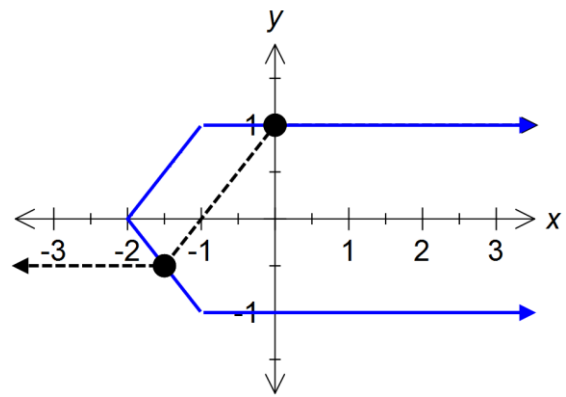

v) $y = x \times f(x)$

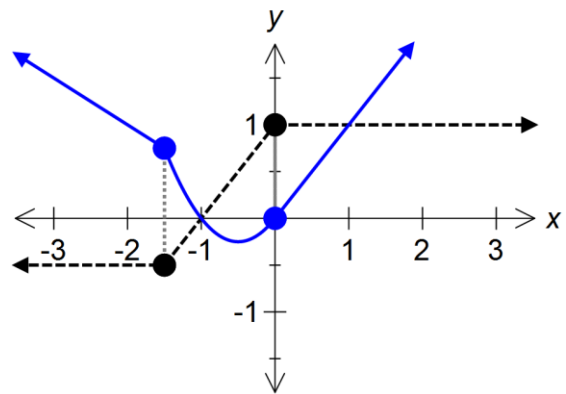

Question 3:

a) Forces Diagram:

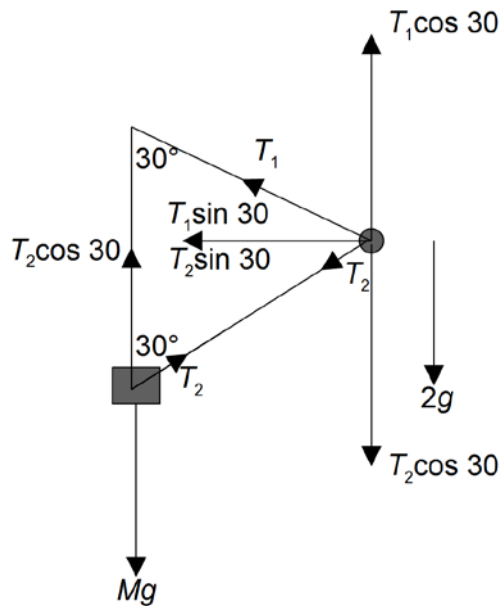

Dimensions Diagram:

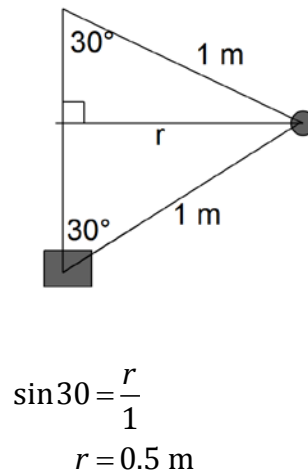

At M :

$$T_2 \cos 30 = M \times 10$$

$$\frac{\sqrt{3}T_2}{2} = 10M$$

$$T_2 = \frac{20M}{\sqrt{3}}$$

At 2 kg mass:

$$T_1 \cos 30 = 10M + 2 \times 10$$

$$\frac{\sqrt{3}T_1}{2} = 10M + 20$$

$$\sqrt{3}T_1 = 20M + 40$$

$$T_1 = \frac{20M + 40}{\sqrt{3}}$$

$$T_1 \sin 30 + T_2 \sin 30 = 2 \times 0.5 \times 4^2$$

$$\frac{T_1}{2} + \frac{T_2}{2} = 16$$

$$T_1 + T_2 = 32$$

$$\frac{20M + 40}{\sqrt{3}} + \frac{20M}{\sqrt{3}} = 32$$

$$20M + 40 + 20M = 32\sqrt{3}$$

$$40M + 40 = 32\sqrt{3}$$

$$40M = 32\sqrt{3} - 40$$

$$M = \frac{32\sqrt{3} - 40}{40}$$

$$M = \frac{4\sqrt{3} - 5}{5} \text{ kg}$$

b)

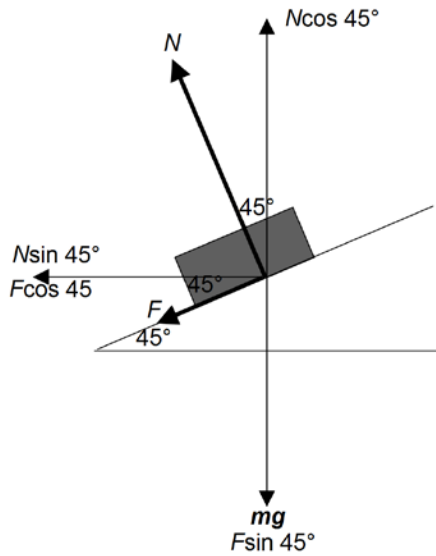

$$N \cos 45 = mg + F \sin 45$$

$$N \sin 45 + F \cos 45 = \frac{mv^2}{10}$$

When $F = \frac{1}{9}N$:

$$N \cos 45 = mg + \frac{1}{9}N \sin 45$$

$$\frac{N}{\sqrt{2}} = 10m + \frac{N}{9\sqrt{2}}$$

$$\frac{8N}{9\sqrt{2}} = 10m$$

$$N = \frac{45\sqrt{2}m}{4} \text{-----(1)}$$

$$N \sin 45 + \frac{1}{9}N \cos 45 = \frac{mv^2}{10}$$

$$\frac{N}{\sqrt{2}} + \frac{N}{9\sqrt{2}} = \frac{mv^2}{10}$$

$$\frac{10N}{9\sqrt{2}} = \frac{mv^2}{10}$$

$$N = \frac{9\sqrt{2}mv^2}{100} \text{---(2)}$$

Equating (1) and (2):

$$\frac{45\sqrt{2}m}{4} = \frac{9\sqrt{2}mv^2}{100}$$

$$v^2 = \frac{45}{4} \times \frac{100}{9}$$

$$= 125$$

$$v = 5\sqrt{5} \text{ ms}^{-1}$$

Question 4

a.

i.

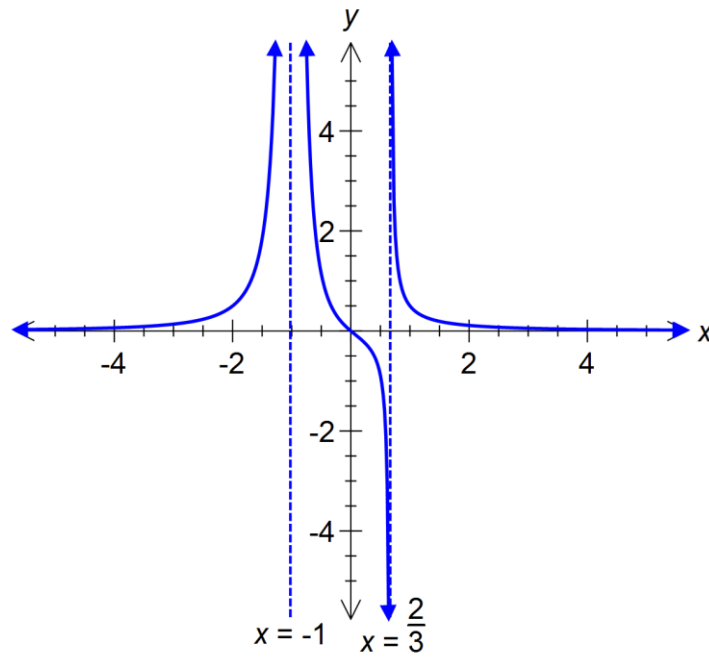

ii.

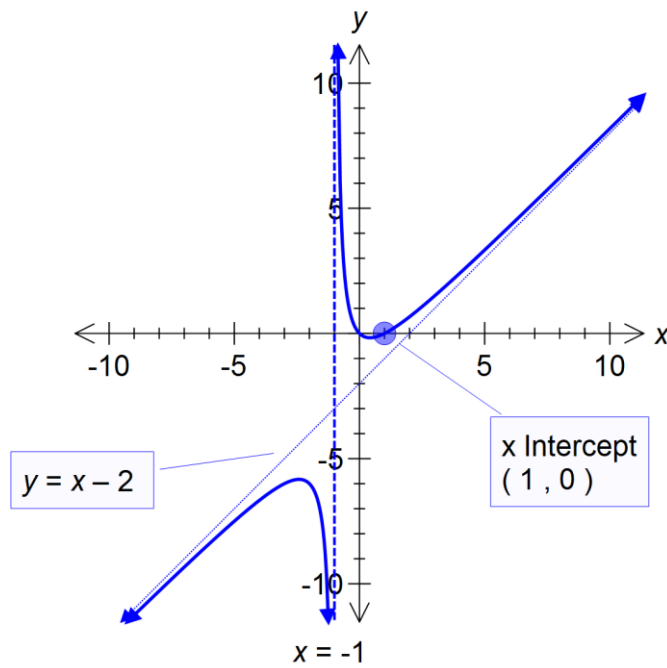

b.

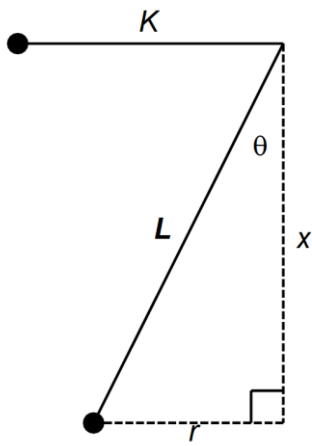

$$\sin \theta = \frac{r}{L}$$

$$\cos \theta = \frac{x}{L}$$

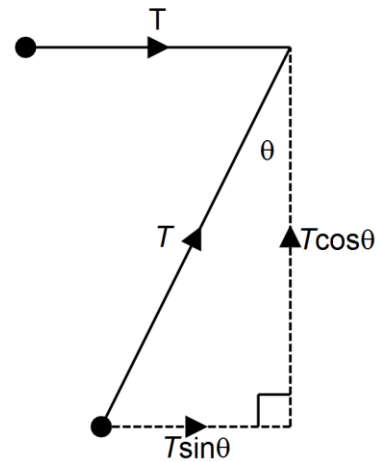

i. Mass below table

Vertically:

$$N + T \cos \theta = qg$$

$$N + \frac{Tx}{L} = qg \rightarrow (1)$$

Horizontally:

$$T \sin \theta = qrR^2$$

$$\frac{Tr}{L} = qrR^2$$

$$T = qLR^2 \rightarrow (2)$$

Substituting (2) into (1)

$$N + \frac{qLR^2x}{L} = qg$$

$$N + qR^2x = qg$$

$$N = q(g - xR^2)$$

ii.

$$q(g - xR^2) > 0$$

$$g - xR^2 > 0$$

$$xR^2 < g$$

$$R^2 < \frac{g}{x}$$

$$R < \sqrt{\frac{G}{X}}$$

iii. The bottom particle will lift off the floor.

iv. Mass on Table:

$$T = mK\omega^2 \rightarrow (3)$$

Equating (1) and (3)

$$mK\omega^2 = qLR^2$$

$$\frac{L}{K} = \frac{m}{q} \left(\frac{\omega}{R} \right)^2$$