

Name:	
Class:	

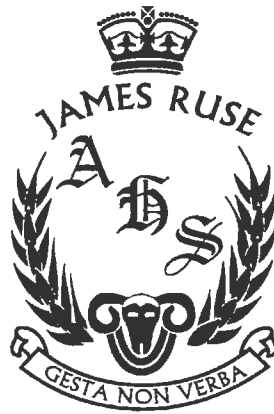

YEAR 12

**ASSESSMENT TEST 3
TERM 2, 2012**

MATHEMATICS EXTENSION 2

*Time Allowed – 90 Minutes
(Plus 5 minutes Reading Time)*

- *All* questions may be attempted
- *All* questions are of equal value
- Department of Education approved calculators are permitted
- In every question, show all necessary working
- Marks may not be awarded for careless or badly arranged work
- No grid paper is to be used unless provided with the examination paper

The answers to all questions are to be returned in separate bundles clearly labeled Question 1, Question 2, etc. Each question must show your Candidate Number.

- Q 1. (a) Given that the line l is $ax + by = 1$ intersects the Rectangular hyperbola $H: xy = c^2$ at two distinct points $P_1(x_1, y_1)$ and $P_2(x_2, y_2)$.
The point $M(x_M, y_M)$ is the midpoint of P_1P_2 .

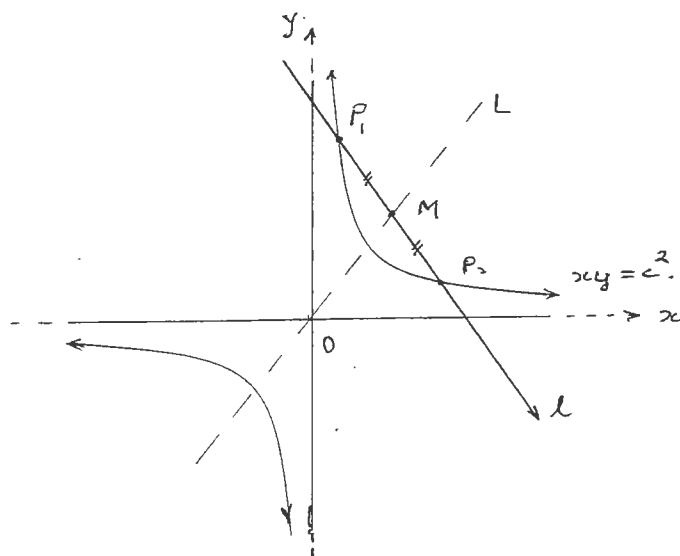

Not to scale

- (i) Find the quadratic equation whose roots are x_1 and x_2 . 1
- (ii) Hence, Show that the equation of line l can be expressed as $\frac{x}{x_M} + \frac{y}{y_M} = 2$. 2
- (iii) Deduce that every line L (not including the asymptotes) through the centre of the rectangular hyperbola bisects all chords parallel to a certain direction. 2
Describe how this direction is related to the direction of L .

- Q 1. (b)

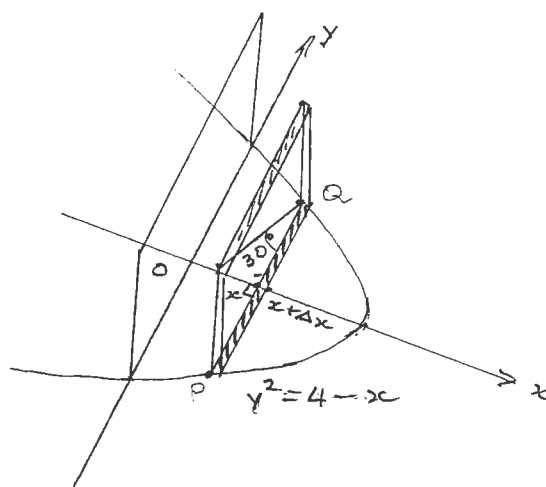

Not to scale

The base of a solid S shown in the diagram above is the region in the xy -plane enclosed between the parabola $y^2 = 4 - x$ and the y -axis.

Each cross section perpendicular to the x -axis is a rectangle whose diagonal makes an angle of 30° with its length.

- (i) By taking a slice of the solid S of thickness Δx at a distance x from the y -axis. Find the area of this slice in terms of x . 2
- (ii) Find the volume of the solid S . 2

Q 1(c) continued over the page:

Q1. (c)

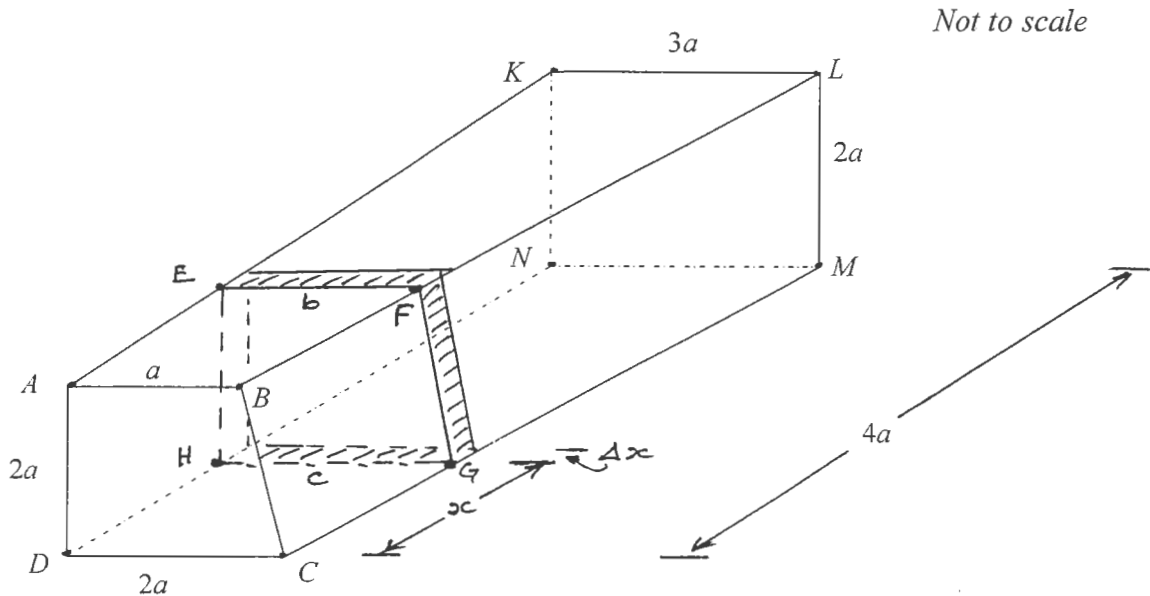

A block of clay originally a rectangular prism has been sliced and a part removed. The diagram above shows the remaining shape. Its length is $4a$ cm. The front $ABCD$ is a trapezium with parallel sides AB and DC a cm and $2a$ cm respectively.

The back face $KLMN$ is a rectangle with a length of $3a$ cm and width $2a$ cm.

By considering a slice $EFGH$ at a distance x cm from the front face $ABCD$ of thickness Δx cm.

This slice is in the shape of a trapezium. The lengths of its parallel sides EF and GH are b cm and c cm respectively, as shown in the diagram.

- (i) Show that the cross-sectional area of this slice is $(3a^2 + \frac{3}{4}ax)$ cm² 4
- (ii) Hence, or otherwise find the volume of the remaining block of clay. 2

Q 2. [START A NEW PAGE]

- (a) A solid S is formed by rotating the region bounded by the parabola $y^2 = 16(1 - x)$ and the y -axis 360° about the line $x = 2$, as shown.

Not to scale

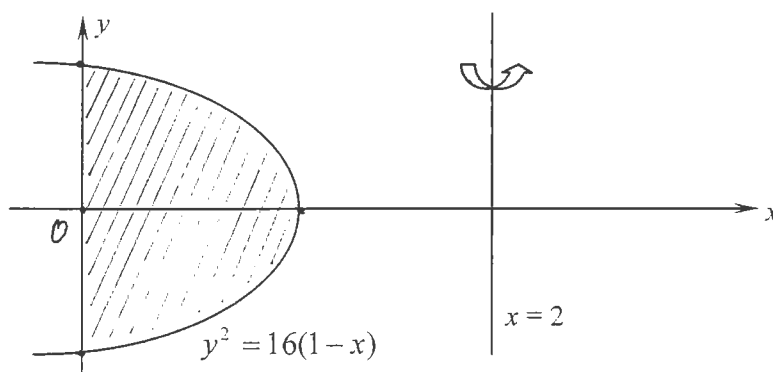

- (i) By taking slices perpendicular to the axis of rotation of thickness Δy , Find the exact value of S . 4
- (ii) By using the method of cylindrical shells, show that the volume V of S can be determined from: $V = 16\pi \int_0^1 (2 - x)\sqrt{1 - x} dx$. 2
- (b) Suppose that the gravitational attraction between two planets is inversely proportional to x^3 , where x is the distance in kilometres between their centres. A particle is projected from the surface of one planet with an initial velocity of U km/s.
- Its distance x from the centre of the planet satisfies equation: $\ddot{x} = -\frac{gR^3}{x^3}$, where g is the magnitude of the acceleration due to gravity at the surface and R is the radius of this planet. [DO NOT prove this result].
- (i) Show that the velocity v m/s of the particle is given by: 2
- $$v^2 = U^2 - gR + \frac{gR^3}{x^2}.$$
- (ii) State the condition for the particle not to return to the planet. 1
- (iii) Show that the displacement x of the particle is given by: $x^2 = R^2 + 2URt + (U^2 - gR)t^2$, provided $U^2 \neq gR$. 3
- (iv) If $U < \sqrt{gR}$, explain why the particle reaches a fixed distance H km (from the centre) above the planet. 3
Include in your answer the expression for this distance H km travelled and the time T seconds taken (in terms of U , R and g).

Q 3. [START A NEW PAGE]

- (a) Given the Rectangular hyperbola $xy = 9$, with two variable points $P\left(3p, \frac{3}{p}\right)$ and $Q\left(3q, \frac{3}{q}\right)$ on it, such that the chord PQ passes through the point $W(0, 6)$.
The midpoint of PQ is the point M .

- (i) Sketch the rectangular hyperbola showing the points P , Q , W and M . 1
- (ii) Show that the equation of the secant PQ is $x + pqy = 3(p + q)$. 1
- (iii) Hence, deduce that $p + q = 2pq$. 1
- (iv) Hence, or otherwise deduce that the tangent drawn from W to the rectangular hyperbola touches the curve at $(3, 3)$. 2
- (v) Find the equation of the locus of M as P and Q move on the hyperbola. 3

Q 3. (b) continued over the page.

- Q 3. (b) A small bead of mass 2 kg is attached to one end of a light string of length 1 metre. The other end of the string is fixed at a height H metres, where $H < 2$, above the centre of a sphere of radius 1 metre. The bead moves in a circle of radius r metres on the surface of the sphere and has a constant angular velocity of ω radians per second, where $\omega > 0$. The string makes an angle of θ with the vertical, as shown in the diagram.

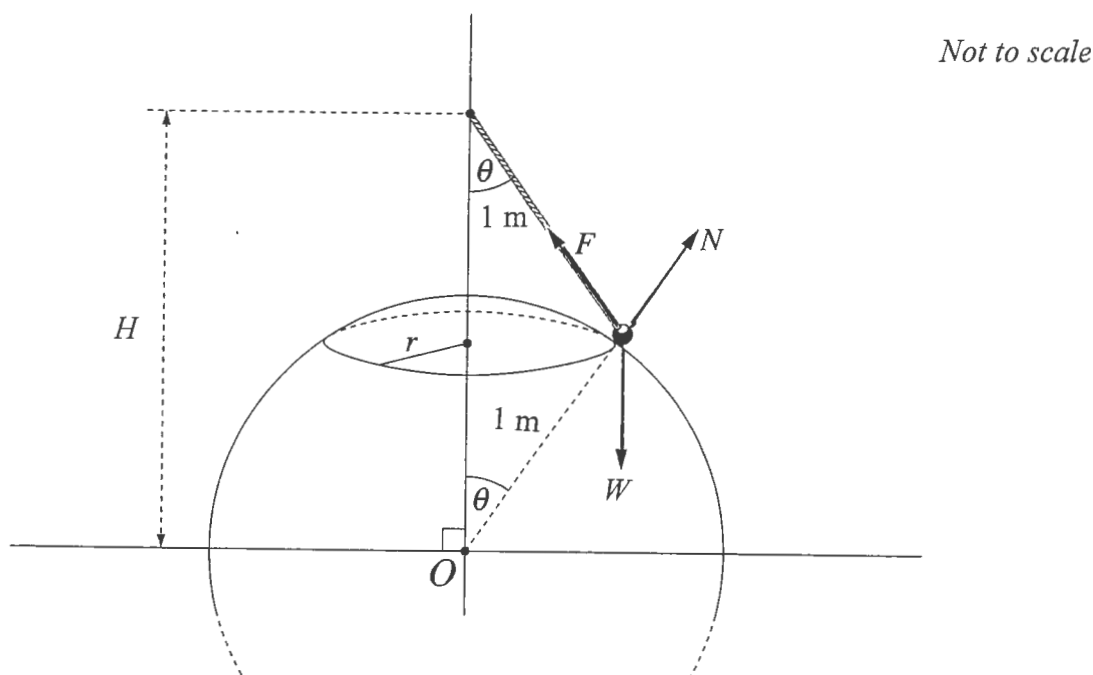

Three forces are acting on the bead: the tension force T of the string, the normal force N to the surface of the sphere and the gravitational force W . [All forces are in Newtons]. Take acceleration due to gravity as $g \text{ m/s}^2$.

- (i) By resolving the forces horizontally and vertically *in a diagram* on your writing paper, show that: 2

$$T \sin \theta - N \sin \theta = 2r\omega^2$$

$$T \cos \theta + N \cos \theta = 2g.$$

- (ii) Hence show that: $N = g \sec \theta - r\omega^2 \operatorname{cosec} \theta$. 2

- (iii) If ω_0 is the maximum angular velocity for which the small bead stays in contact with the surface and $\omega = k\omega_0$ for some $0 < k < 1$. Describe qualitatively what would happen to the motion of the bead if ω were to increase to ω_0 and then exceed ω_0 . 3
Find ω_0 in terms of g and H .

Q 4. [START A NEW PAGE]

- (a) An special toy object of mass 1 kg is dropped from a tall building.
 At first, air resistance causes a resistive force of magnitude $\frac{v}{10}$ newtons,
 where v m/s is the speed of the object t seconds after it is dropped.
- (i) By taking acceleration due to gravity as 10 m/s^2 , explain why the 1
 toy object has the equation of motion of: $\ddot{x} = 10 - \frac{v}{10}$,
 where x is the distance the toy has fallen in the first t seconds.
- (ii) Show that the speed W m/s of the toy when it has fallen 40 m 3
 satisfies the equation: $W + 100 \ln\left(1 - \frac{W}{100}\right) + 4 = 0$.
- (b) After the toy has fallen the 40 metres and has reached the speed of W m/s, a very
 small parachute opens and the air resistance now causes a resistive force to its
 motion of magnitude $\frac{v^2}{10}$ newtons.
- (i) Write down the new acceleration \ddot{x} of the toy, where x is now the 1
 distance that the toy has fallen in the first t seconds after the parachute
 has opened.
- (ii) Find the terminal velocity of the toy. 1
- (iii) Show that: $v^2 = 100 - (100 - W^2)e^{-\frac{1}{5}x}$. 2
- (iv) Show that t seconds after the parachute opens, 2

$$t = \frac{1}{2} \ln\left(\frac{(W - 10)(v + 10)}{(W + 10)(v - 10)}\right)$$
 [you may make use of $\int \frac{dx}{a^2 - x^2} = \frac{1}{2a} \ln\left|\frac{a + x}{a - x}\right| + c$].
- (v) Given that the solution to the equation in part (a) (ii) is $W \approx 25.7$, 1
 how long after the parachute opens does the toy reach 107% of its
 terminal velocity correct to 2 decimal places?

Q 4. (c) continued over the page.

- Q 4.** (c) A particle of mass m kg moves in a vertical line, starting initially at rest at point O with a driving force of F newtons under gravitational pull, where F is given by:

$$F = \begin{cases} \frac{mk}{(T+t)^2} & \text{for } 0 \leq t \leq T \\ 0 & \text{for } t > T \end{cases}, \text{ where constants } k \text{ and } T > 0.$$

- (i) Show that the velocity v m/s of the particle at time t is given by: **2**

$$v = \frac{-k}{T+t} - g\cancel{t} + \frac{k}{T}, \text{ for } 0 \leq t \leq T.$$

- (ii) Show that when $t = T$, the height reached by the particle above O is **2**

$$k(1 - \ln 2) - \frac{1}{2}gT^2 \text{ metres.}$$

- (iii) Show that the particle will continue to move upwards provided **1**

$$k > 2gT^2, \text{ for } t \geq T. .$$

THE END



MATH EXT 2 TERM 2 2012 AT3 SOLUTIONS.

①

MATHEMATICS Extension 2: Question 1

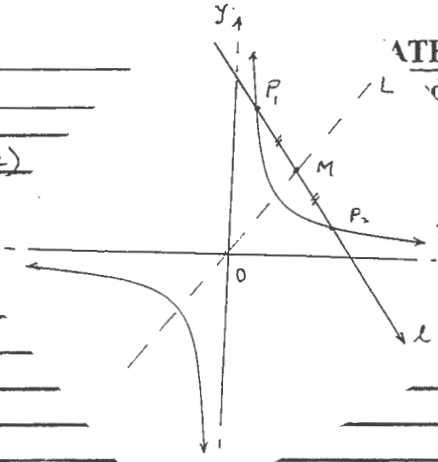
	Solutions	Marks	Marker's Comments
	<p>(i) For the points of intersection</p> $xy = c^2 \quad (1)$ $ax + by = 1 \quad (2)$ $\therefore ax^2 + bxy = x$ $\text{i.e. } acx^2 + bc^2 = x$ $\therefore acx^2 - x + bc^2 = 0$		1
<p>(ii)</p> <p>Now $x_1 + x_2 = \frac{-b}{a} = \frac{-1}{a}$</p> $\frac{x_1 + x_2}{2} = \frac{-1}{2a}$ <p>i.e. $x_M = \frac{-1}{2a}$</p> <p>So $a = \frac{-1}{2x_M}$</p> <p>as pt M lies on l</p> $\therefore ax_M + by_M = 1$ <p>i.e. $\frac{-1}{2} + by_M = 1 \Rightarrow y_M = \frac{1}{2b}$</p> <p>$\therefore b = \frac{1}{2y_M}$</p> <p>$\therefore$ l becomes $\frac{-1}{2x_M}x + \frac{1}{2y_M}y = 1$</p> $\Rightarrow \frac{x}{x_M} + \frac{y}{y_M} = 2 \text{ good}$	<p>MIDPT $P_1P_2 = M(\frac{x_1+x_2}{2}, \frac{y_1+y_2}{2})$</p>		2
<p>(iii) APPROACH #1</p> <p>Let line L be $y = mx$</p> <p>As M lies on this line</p> $m_L = \frac{y_M}{x_M} = \frac{\frac{1}{2b}}{\frac{-1}{2a}} = \frac{a}{b}$ <p>BUT for line l: $ax + by = 1$</p> $m_l = -\frac{a}{b}$ <p>\therefore OPPOSITE IN SIGN (Gradients)</p> <p>the direction of the chords which have their midpoints M on this line can be determined by reflection of the line in either axis</p>	<p>OR $y = mx \quad (1)$</p> $\frac{x}{x_M} + \frac{y}{y_M} = 2 \quad (2)$ <p>Pt of intersection $x = \frac{2x_M y_M}{mx_M + y_M} \equiv x_M$ gives $m_L = m = \frac{y_M}{x_M} = \frac{a}{b}$</p> <p>and again $m_l = -\frac{a}{b}$</p>		2

MATHEMATICS Extension 2: Question.....

Suggested Solutions

Marks

Marker's Comments

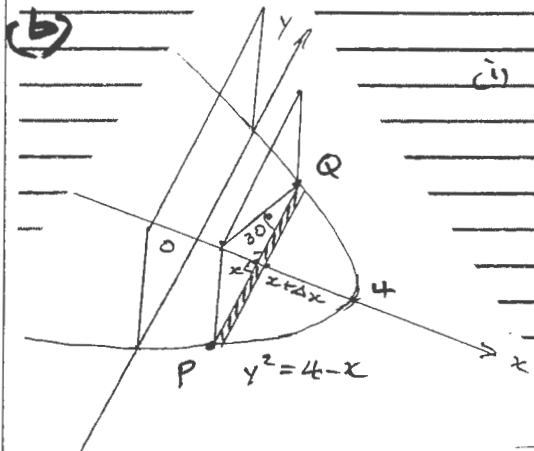

(i) $\delta x \equiv \Delta x$

Let $P(x, -y)$ $Q(x, y)$

$PQ = 2y$

$\tan 30^\circ = \frac{\text{height } h}{PQ} = \frac{h}{2y}$

$\therefore h = \frac{2y}{\sqrt{3}}$

$\therefore \text{Area} : A = PQ \times h$
 $\text{x.S.A} = 2y \times \frac{2y}{\sqrt{3}}$

$= \frac{4y^2}{\sqrt{3}}$

$A(x) = \frac{4(4-x)}{\sqrt{3}}$

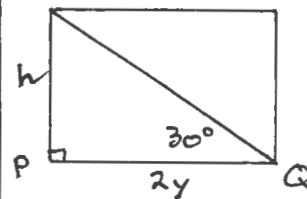

"A = b x h"

2

(ii) \therefore volume of slice $\Delta V \doteq A \cdot \Delta x = \frac{4(4-x)}{\sqrt{3}} \Delta x$

Volume of solid $V \doteq \sum_{i=1}^n \Delta V_i = \sum_{i=1}^n \frac{4(4-x)}{\sqrt{3}} \Delta x$

$\therefore V = \lim_{n \rightarrow \infty, \Delta x \rightarrow 0} \sum_{i=1}^n \frac{4(4-x)}{\sqrt{3}} \Delta x$

i.e. $V = \frac{4}{\sqrt{3}} \int_0^4 (4-x) dx$

$= \frac{-4}{2\sqrt{3}} [(4-x)^2]_0^4 = \frac{4}{\sqrt{3}} [4x - \frac{1}{2}x^2]_0^4$

$= \frac{-2}{\sqrt{3}} [0 - 4^2]$

$= + \frac{32}{\sqrt{3}}$

\therefore Volume of S is $\frac{32\sqrt{3}}{3}$ units³

2

MATHEMATICS Extension 2: Question.....!

Suggested Solutions

Marks

Marker's Comments

(c) APPROACH #1 Using coord geom as lengths

change at a linear rate

(i) Area of GHFE $A = \frac{h}{2}(a+b)$
 $= \frac{2c}{2}(c+b)$
 $A = c^2(c+b)$

* CAN USE Δ TRIG AREA OF TRAPS to find b and c

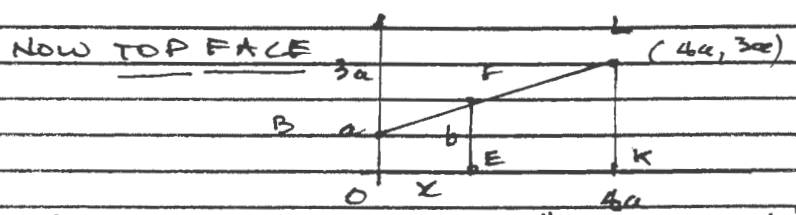

\therefore coords F = (x, y) ; $y = mx + b$
 i.e. $y = \frac{2c}{4a}x + a$

$\therefore EF = b = \frac{1}{2}x + a$

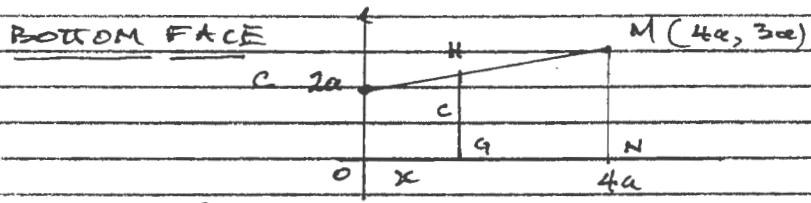

coords of H = (x, y) ; $y = mx + b$
 i.e. $y = \frac{a}{4a}x + 2a$

$\therefore GH = c = \frac{1}{4}x + 2a$

$\therefore A(x) = a \left[\frac{1}{4}x + 2a + \frac{1}{2}x + a \right]$
 $= a \left(3a + \frac{3}{4}x \right) = 3a^2 + \frac{3}{4}ax$

4

(ii) \therefore Volume of slice $\Delta V = (3a^2 + \frac{3}{4}ax) \Delta x$

Volume of solid $V = \sum_{i=1}^n (3a^2 + \frac{3}{4}ax) \Delta x$
 $= \lim_{n \rightarrow \infty} \sum_{i=1}^n (3a^2 + \frac{3}{4}ax) \Delta x$
 $= \int_0^{4a} (3a^2 + \frac{3}{4}ax) dx$
 $= \left[3a^2x + \frac{3}{8}ax^2 \right]_0^{4a}$
 $= 12a^3 + \frac{3}{8}a \times 16a^2$
 $V = 12a^3 + 6a^3$
 $V = 18a^3$
 \therefore Volume is $18a^3$ units³.

2

MATHEMATICS Extension 2: Question 2

Suggested Solutions

Marks

Marker's Comments

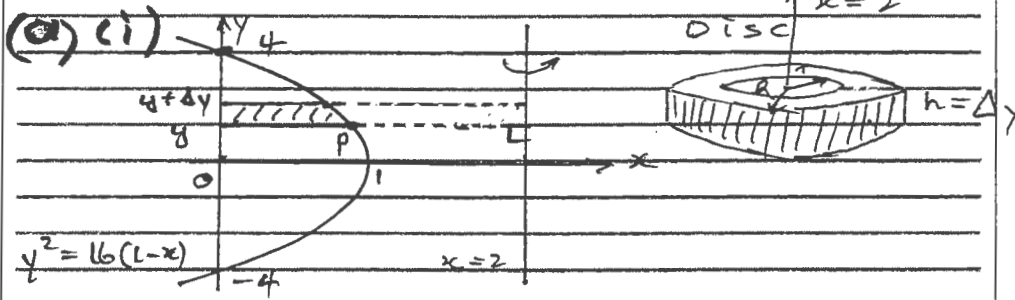

CROSS-SECTIONAL AREA $A = \pi R^2 - \pi r^2 = \pi [R^2 - r^2] = \pi [R+r][R-r]$
 $= \pi [4-x][x]$
 $\therefore A(x) = \pi x(4-x)$

VOLUME OF SLICE

$$\Delta V \doteq \pi x(4-x) \Delta y$$

VOLUME OF SOLID $V \doteq \sum_{i=1}^n \Delta V = \sum_{i=1}^n \pi (4x - x^2) \Delta y$

$$\therefore V = \lim_{\Delta y \rightarrow 0} \sum_{i=1}^n \pi (4x - x^2) \Delta y$$

$$= \pi \int_{-4}^4 (4x - x^2) dy = \pi \int_{-4}^4 x(4-x) dy$$

BUT as $y^2 = 16(L-x)$

$$\therefore x = L - \frac{1}{16} y^2$$

$$\therefore V = \pi \int_{-4}^4 (L - \frac{1}{16} y^2)(4 - (L - \frac{1}{16} y^2)) dy$$

$$= \pi \int_{-4}^4 (1 - \frac{1}{16} y^2)(3 + \frac{1}{16} y^2) dy$$

$$= \pi \int_{-4}^4 (3 - \frac{2}{16} y^2 - \frac{1}{256} y^4) dy$$

$$\equiv 2 \times \pi \int_0^4 (3 - \frac{1}{8} y^2 - \frac{1}{256} y^4) dy$$

$$= 2\pi [3y - \frac{1}{24} y^3 - \frac{1}{1280} y^5]_0^4$$

$$= 2\pi [12 - \frac{64}{24} - \frac{4^5}{4^4 \times 5}] - 0$$

$$V = \frac{256\pi}{15}$$

\therefore Volume is $\frac{256\pi}{15}$ units³

$$r = 2-x$$

$$R = 2$$

$$\pi [2^2 - (2-x)^2]$$

$$\pi \int_{-4}^4 x(4-x) dy$$

$$x = \frac{16-y^2}{16} =$$

as an EVEN FN

$$\frac{1024}{1280} = \frac{4}{5}$$

$$53.6 \text{ u}^3 \text{ (dp)}$$

4

MATHEMATICS Extension 2: Question 2

Suggested Solutions

Marks

Marker's Comments

(a) (ii)

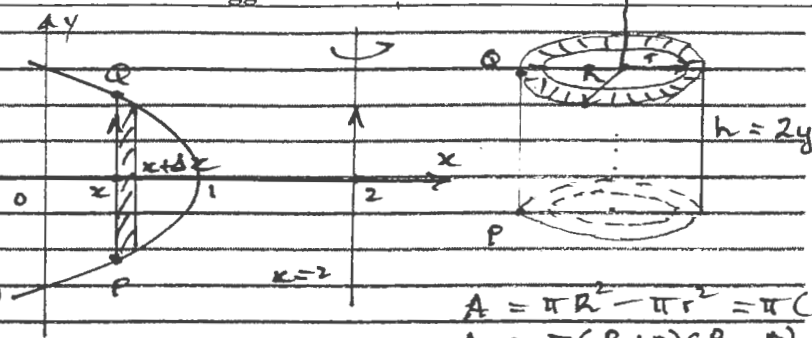

$y^2 = 16(1-x)$

$A = \pi R^2 - \pi r^2 = \pi (R^2 - r^2)$

$A = \pi (R+r)(R-r)$

CYLINDRICAL SHELLS

$A = \pi [2(2-x) + \Delta x] [\Delta x]$
 $A \doteq 2\pi(2-x)\Delta x$ (take $(\Delta x)^2 \doteq 0$)

\therefore volume of slice $\Delta V \doteq 2\pi(2-x)\Delta x \times 2y = 4\pi(2-x)y\Delta x$

volume of solid $V \doteq \sum_1^n 4\pi(2-x)y\Delta x$

$V = \lim_{n \rightarrow \infty} \sum_0^1 4\pi(2-x)y\Delta x$
 $\Delta x \rightarrow 0$

$= 4\pi \int_0^1 (2-x)y dx$

$= 4\pi \int_0^1 (2-x)4\sqrt{1-x} dx$

$V = 16\pi \int_0^1 (2-x)\sqrt{1-x} dx$

cs upper curve is $y = +\sqrt{16(1-x)} = 4\sqrt{1-x}$

2

qed

Suggested Solutions

Marks

Marker's Comments

(b) (i) $t=0$ $x=R$ $v=U$

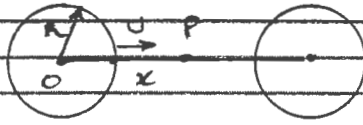

$$\ddot{x} = -\frac{gR}{x^3}$$

$$\frac{d}{dx} \left(\frac{1}{2} v^2 \right) = -gR^3 x^{-3}$$

$$\int_0^v d\left(\frac{1}{2} v^2\right) = -gR^3 \int_R^x x^{-3} dx$$

$$\frac{1}{2} [v^2 - U^2] = +\frac{1}{2} gR^3 \left[x^{-2} \right]_R^x$$

$$\frac{1}{2} [v^2 - U^2] = \frac{1}{2} gR^3 \left[\frac{1}{x^2} - \frac{1}{R^2} \right]$$

$$v^2 - U^2 = gR^3 \left[\frac{1}{x^2} - \frac{1}{R^2} \right]$$

$$\therefore v^2 = U^2 - gR + \frac{gR^3}{x^2} \quad \text{qed}$$

$\ddot{x} = -\frac{\mu}{x^3}$ $x=R$
 $\ddot{x} = -g$
 $\therefore \mu = gR^3$

Note
 $c = \frac{1}{2} U^2 - \frac{1}{2} gR$

2

(ii) Not to return $\Rightarrow v^2$ cannot be < 0

$$\therefore v^2 - gR > 0$$

$$\text{i.e. } U^2 > gR \quad \text{or } U > \sqrt{gR}$$

1

(iii) As moving away $v = \frac{dx}{dt} = \sqrt{U^2 - gR + \frac{gR^3}{x^2}}$

$$\frac{dx}{dt} = \sqrt{\frac{(U^2 - gR)x^2 + gR^3}{x^2}}$$

$$= \frac{\sqrt{(U^2 - gR)x^2 + gR^3}}{x} \quad \text{as } \sqrt{x^2} = |x| = x \text{ as } x > 0$$

$$\therefore \frac{x dx}{\sqrt{gR^3 + (U^2 - gR)x^2}} = dt$$

$$\int_R^x \frac{x dx}{\sqrt{gR^3 + (U^2 - gR)x^2}} = \int_0^t dt$$

$$\left[\frac{1}{U^2 - gR} \sqrt{gR^3 + (U^2 - gR)x^2} \right]_R^x = t$$

$$\therefore \frac{1}{U^2 - gR} \left[\sqrt{gR^3 + (U^2 - gR)x^2} - \sqrt{gR^3 + (U^2 - gR)R^2} \right] = t$$

$$\sqrt{gR^3 + (U^2 - gR)x^2} - \sqrt{gR^3 + U^2 R - gR^3} = (U^2 - gR)t$$

$$\sqrt{gR^3 + (U^2 - gR)x^2} - UR = (U^2 - gR)t$$

$$\text{so } gR^3 + (U^2 - gR)x^2 = [(U^2 - gR)t + UR]^2$$

$$(U^2 - gR)x^2 = (U^2 - gR)^2 t^2 + 2UR(U^2 - gR)t + U^2 R^2$$

$$\therefore x^2 = R + 2URt + (U^2 - gR)t^2$$

qed. $U^2 \neq gR$

3

MATHEMATICS Extension 2: Question.....2

Suggested Solutions	Marks	Marker's Comments
<p>(b) (iv) * Assume $U \geq \sqrt{gR}$ (or $U \geq \sqrt{gR}$) then $U^2 - gR \geq 0$ $\therefore x^2 \geq R^2 + 2\sqrt{gR} \cdot Rt + (gR - gR)t^2$ using (iii) i.e. $x^2 \geq R^2 + 2\sqrt{gR} \cdot t$ $x^2 > R^2$ as $t > 0$ i.e. $x > R \therefore$ never returns - escapes!</p>		
<p>OR as $v^2 = U^2 - gR + \frac{gR^3}{x^2}$ $v^2 \geq \frac{gR^3}{x^2}$ $\Rightarrow v^2 \neq 0$ as $x > 0$ so continues onwards \therefore never returns - escapes,</p>		
<p>So to reach a max distance $U < \sqrt{gR}$</p>		
<p>$\therefore t = T \quad x = H \quad v = 0$</p>		
<p>$\therefore 0 = U^2 - gR + \frac{gR^3}{H^2}$ using (i)</p>		
<p>$\Rightarrow H^2 = \frac{gR^3}{gR - U^2}$</p>		
<p>using (iii) $H^2 = \frac{gR^3}{gR - U^2} = R^2 + 2UR T + (U^2 - gR)T^2$</p>		
<p>produces $(gR - U^2)^2 T^2 - 2UR(gR - U^2)T + U^2 R^2 = 0$</p>		
<p>i.e. $[(gR - U^2)T - UR]^2 = 0$</p>		
<p>\therefore Time taken $T = \frac{UR}{gR - U^2}$</p>		

3

MATHEMATICS Extension 2: Question 3

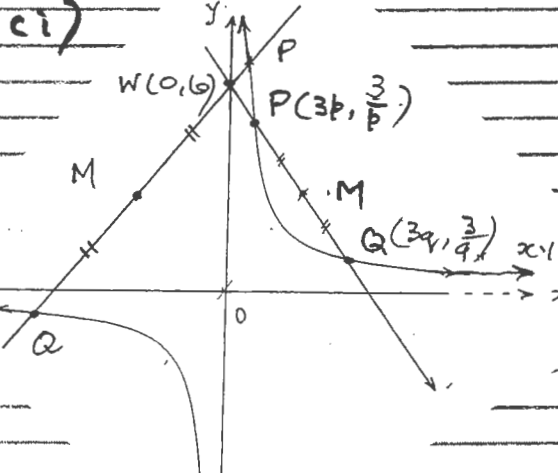
Suggested Solutions	Marks	Marker's Comments
<p>(a) (i)</p> 		<div style="border: 1px solid black; width: 20px; height: 20px; margin: auto;"></div>
<p>(ii) Gradient $m_{PQ} = \frac{\frac{3}{q} - \frac{3}{p}}{3q - 3p} = \frac{3(p-q)}{-3pq(p-q)} = -\frac{1}{pq}$, provided $q \neq p$.</p> <p>\therefore Eqn. of PQ: $y - \frac{3}{p} = -\frac{1}{pq}(x - 3p)$ <u>SECANT</u></p> $pqy - 3q = -x + 3p$ <p>$\therefore x + pqy = 3(p+q)$</p>		<div style="border: 1px solid black; width: 20px; height: 20px; margin: auto;"></div>
<p>(iii) As $W(0,6)$ lies on this secant</p> $0 + pq \cdot 6 = 3(p+q)$ <p>$\therefore 2pq = p+q$ <u>qed.</u></p>		<div style="border: 1px solid black; width: 20px; height: 20px; margin: auto;"></div>
<p>(iv) when WPQ is tangent to the hyperbola then $q=p$</p> <p>$\therefore 2p \cdot p = p+p$ $2p^2 = 2p$ $\therefore p(p-1) = 0$ $\therefore p=0$ or $p=1$ but $p \neq 0 \therefore p=1$ \Rightarrow Point of contact FROM W is $(3,3)$</p> <p>OR when WPQ is a tangent at say Z Tangent eqn. $x + p^2y = 6p$ — (1) $xy = 9$ — (2)</p> <p>Point of contact on solving gives $(3,3)$ need to show the steps.</p>		<div style="border: 1px solid black; width: 20px; height: 20px; margin: auto; display: inline-block; padding: 2px;">2</div>

MATHEMATICS Extension 2: Question 3

Suggested Solutions	Marks	Marker's Comments
<p>Q3(a)(v) Midpoint of PQ is $M = \left(\frac{3(p+q)}{2}, \frac{3(p+q)}{2pq}\right)$</p> <p>Let $M(x, y)$ be the general point on the required locus</p> <p>$\therefore x \equiv \frac{3(p+q)}{2} \quad \text{--- (1)}$</p> <p>$y \equiv \frac{3(p+q)}{2pq} \quad \text{--- (2)}$</p> <p>$p+q = 2pq \quad \text{--- (3)}$</p> <p>From (3) $\frac{p+q}{pq} = 2$</p> <p>$\therefore y = \frac{3}{2} \times 2 = 3$</p> <p>$x = \frac{3}{2}(p+q)$</p>		
<p><u>Restrictions</u></p> <ul style="list-style-type: none"> • For $p, q > 0$: $p+q > 0$ since tangent from W touches hyperbola at $(3, 3)$ $\therefore y = 3$ for $x \geq 3$ • For $\begin{cases} p > 0, q < 0 \\ p < 0, q > 0 \end{cases}$: $pq < 0$ so $p+q < 0$ $\therefore x < 0$ 		3
<p>\therefore Locus of M is the horizontal line $y = 3$ for $x < 0$ or $x \geq 3$</p>		

MATHEMATICS Extension 2: Question.....**3**

Suggested Solutions

Marks

Marker's Comments

(b) (i)

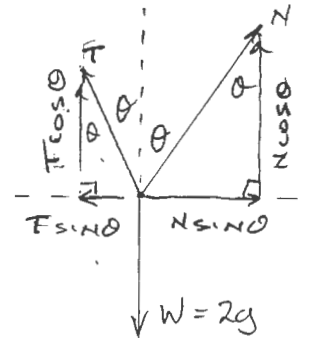
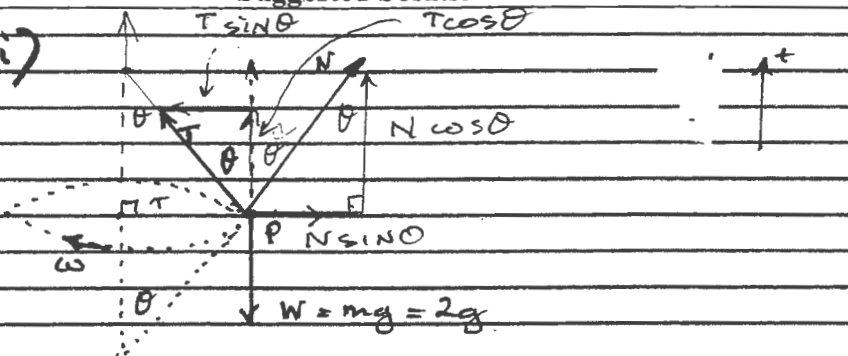

RESOLVE

HORIZONTALLY at P

VERTICALLY at P

$$T \sin \theta - N \sin \theta = 2r\omega^2$$

$$\text{i.e. } T \sin \theta - N \sin \theta = 2r\omega^2$$

$$T \cos \theta + N \cos \theta - W = m \times 0$$

$$T \cos \theta + N \cos \theta = W = 2g$$

2

(ii)

$$T \sin \theta - N \sin \theta = 2r\omega^2 \quad \text{--- (1)}$$

$$T \cos \theta + N \cos \theta = 2g \quad \text{--- (2)}$$

$$\cdot \times (1): T \cos \theta \sin \theta - N \cos \theta \sin \theta = 2r\omega^2 \cos \theta \quad \text{--- (3)}$$

$$\sin \theta \times (2): T \sin \theta \cos \theta + N \sin \theta \cos \theta = 2g \sin \theta \quad \text{--- (4)}$$

$$(4) - (3) \quad 0 \quad 2N \sin \theta \cos \theta = 2g \sin \theta - 2r\omega^2 \cos \theta$$

$$\therefore N = \frac{2g \sin \theta}{2 \sin \theta \cos \theta} - \frac{2r\omega^2 \cos \theta}{2 \sin \theta \cos \theta}$$

$$\text{i.e. } N = g \sec \theta - r\omega^2 \csc \theta \quad \text{Q.E.D.}$$

2

(iii) AS ω increases: N decreases, T increases until ω reaches ω_0 when the particle P is on the point of losing contact with the surface

for $\omega > \omega_0$ the particle is no longer in contact / on the surface of the sphere and it moves in a horizontal circle above the hemisphere, and the string makes an angle θ with the vertical which increases as $\omega > \omega_0$.

the bead is in contact when $N \geq 0$

$$\therefore g \sec \theta \geq r\omega^2 \csc \theta$$

$$\text{i.e. } \omega^2 \leq \frac{g \sec \theta}{r \csc \theta} = \frac{g \tan \theta}{r}$$

$$\text{but } \tan \theta = \frac{r}{\frac{1}{2}H} = \frac{2r}{H}$$

$$\therefore \omega^2 \leq \frac{2rg}{rH} \Rightarrow \omega \leq \sqrt{\frac{2g}{H}} \quad \text{as } g \text{ and } H > 0.$$

3

$$\therefore \Rightarrow \omega_0 = \sqrt{\frac{2g}{H}}$$

MATHEMATICS Extension 2: Question 4

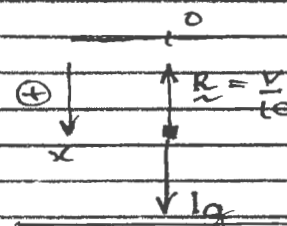
Suggested Solutions	Marks	Marker's Comments
<p>(a) (i) Data: $t=0$ $x=0$ $v=0$ $m=1$ $g=10$</p> <p>FORCE DIAGRAM: EQU. OF MOTION</p>  $1\ddot{x} = 1g - \frac{v}{10}$ $\text{ie } \ddot{x} = 10 - \frac{v}{10}$		1
<p>(ii) $t=T$ $x=40$ $v=W$</p> $\ddot{x} = \frac{d(\frac{1}{2}v^2)}{dx} = 10 - \frac{v}{10}$ $v \frac{dv}{dx} = \frac{1}{10}(100 - v) \quad \text{Note } 0 \leq v < 100$ $\therefore \frac{v}{100-v} dv = \frac{1}{10} dx$ $\int_0^W \frac{v dv}{100-v} = \frac{1}{10} \int_0^{40} dx = \frac{x}{10} \Big _0^{40} = 4$ $\int_0^W (-1 + \frac{100}{100-v}) dv = 4$ $\left[-v - 100 \ln 100-v \right]_0^W = 4 \quad \text{but cos } v < 100 \quad 100-v > 0$ $(-W - 100 \ln(100-W)) - (0 - 100 \ln 100) = 4$ $\therefore W + 4 + 100 \ln(100-W) - 100 \ln 100 = 0$ $\text{ie } W + 4 + 100 \ln\left(\frac{100-W}{100}\right) = 0 \text{ of ed.}$		3
<p>(b) (i) Data take $t=0$ $x=0$ $v=0$</p> $1\ddot{x} = 1g - \frac{v^2}{10} \Rightarrow \ddot{x} = 10 - \frac{v^2}{10}$		1
<p>(ii) For Terminal velocity</p> $\lim_{t \rightarrow \infty} \ddot{x} = 0 \Rightarrow 10 - \frac{v^2}{10} = 0$ $\therefore v^2 = 100 \Rightarrow v = 10, v > 0.$ <p>So Terminal velocity = 10 m/s</p> $\therefore 10 < v \leq W$		1

MATHEMATICS Extension 2: Question.....

Suggested Solutions	Marks	Marker's Comments
<p>(b) (iii) $\ddot{x} = 10 - \frac{v^2}{10} = \frac{1}{10}(100 - v^2)$</p> $v \frac{dv}{dx} = \frac{1}{10} \frac{(100 - v^2)}{x}$ $\int_W^v \frac{v dv}{100 - v^2} = \frac{1}{10} \int_{40}^x \frac{dx}{x}$ $-\frac{1}{2} \ln 100 - v^2 \Big _W^v = \frac{1}{10} \ln \frac{x}{40} = \frac{x}{10}$ $-\frac{1}{2} [\ln(100 - v^2) - \ln(100 - W^2)] = \frac{x}{10}$ $\frac{\ln(100 - v^2)}{(100 - W^2)} = -\frac{2x}{10} = -\frac{x}{5}$ $100 - v^2 = e^{-\frac{x}{5}}$ $\frac{100 - W^2}{100 - v^2} = (100 - W^2) e^{-\frac{x}{5}}$ $\therefore v^2 = 100 - (100 - W^2) e^{-\frac{x}{5}}$		<p>$10 < v \leq W$ $\therefore 100 - v^2 > 0$</p> <p style="text-align: right;">2</p> <p>qed</p>
<p>(iv) $\ddot{x} = \frac{dv}{dt} = \frac{1}{10} (100 - v^2)$</p> $\int_W^v \frac{dv}{100 - v^2} = \frac{1}{10} \int_0^t dt$ $\frac{1}{20} \ln \left(\frac{10+v}{10-v} \right) \Big _W^v = \frac{t}{10}$ $\therefore t = \frac{1}{2} \ln \left(\frac{10+v}{10-v} \right) \div \left(\frac{10+W}{10-W} \right)$ $= \frac{1}{2} \ln \left(\frac{(10+v)(10-W)}{(10-v)(10+W)} \right) = \frac{1}{2} \ln \left(\frac{(W-10)(V+10)}{(W+10)(V-10)} \right)$		<p style="text-align: right;">2</p> <p>qed.</p>
<p>(v) $W = 25.7 \quad v = 107\% \text{ of } V_t = 1.07 \times 10 = 10.7$</p> <p>time taken $t = \frac{1}{2} \ln \left[\frac{(25.7 - 10)(10.7 + 10)}{(25.7 + 10)(10.7 - 10)} \right]$</p> $t = \frac{1}{2} \ln \left(\frac{15.7 \times 20.7}{35.7 \times 0.7} \right) = 1.2826593...$ <p>\therefore time taken = <u>1.28 seconds</u></p>		<p style="text-align: right;">1</p>

105% 1.49s
 110% 1.11

MATHEMATICS Extension 2: Question..... 4

Suggested Solutions	Marks	Marker's Comments
---------------------	-------	-------------------

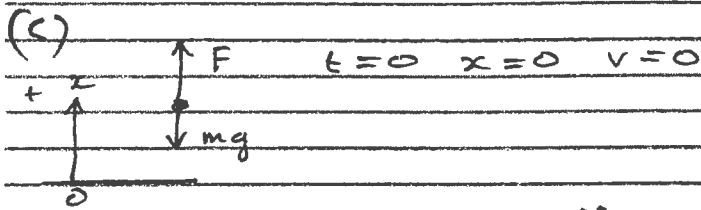

(i) Equ. of motion: $m\ddot{x} = -mg + F$
 $= -mg + \frac{mk}{(T+t)^2}$

$\therefore \ddot{x} = \frac{k}{(T+t)^2} - g$ $0 \leq t \leq T$

$\therefore \frac{dv}{dt} = \frac{k}{(T+t)^2} - g$

$\int_0^v dv = \int_0^t \left(\frac{k}{(T+t)^2} - g \right) dt$

$v = \left[\frac{-k}{T+t} - gt \right]_0^t$

$v = \left(\frac{-k}{T+t} - gt \right) - \left(\frac{-k}{T} - 0 \right)$

$v = \frac{-k}{T+t} - gt + \frac{k}{T}$ *qed*

2

(ii) $v = \frac{dx}{dt} = \frac{-k}{T+t} - gt + \frac{k}{T}$ $t=T$ $x=H$

$\int_0^H dx = \int_0^T \left(\frac{-k}{T+t} - gt + \frac{k}{T} \right) dt$

$= \left[-k \ln(T+t) - \frac{1}{2}gt^2 + \frac{kt}{T} \right]_0^T$

$H = -k \ln 2T - \frac{1}{2}gT^2 + k - (-k \ln T - 0 + 0)$

$H = -k \ln 2T - \frac{1}{2}gT^2 + k + k \ln T$

$H = k \ln \left(\frac{T}{2T} \right) + k - \frac{1}{2}gT^2$

$H = k(1 - \ln 2) - \frac{1}{2}gT^2$

2

(iii) to continue upwards movement from $t=T$; $v > 0$
 \therefore

$v(T) = \frac{-k}{2T} - gT + \frac{k}{T} > 0$

$\frac{k}{2T} - gT > 0$

$\Rightarrow k > 2gT^2$ *qed.*

1