



<b>Student Number</b>	
<b>Mark /</b>	

## Chemistry Assessment

### Task 2 Term 1 2010

#### Production of Materials Acidic Environment & Chemical Monitoring

## Theory

### General Instructions

- Reading time – 5 minutes
- Working time – 55 minutes
- Write using black or blue pen
- Write your Student Number at the top of this page and on pages 7,9 and 11.
- Board-approved calculators may be used

A data sheet and a periodic table are provided at the back of the paper.

**Total Marks – 40**

### Part A – 10 marks

- Attempt Questions 1 – 10
- Allow about 10 minutes for this part

### Part B – 30 marks

- Attempt Questions 11 – 17
- Allow about 45 minutes for this part

**Part A: Multiple Choice:**  
**Attempt Questions 1 – 10**  
**Allow about 10 minutes for this part**

---

Select the alternative A, B, C or D that best answers the question. Fill in the response oval completely.

**Sample:**  $2 + 4 =$  (A) 2 (B) 6 (C) 8 (D) 9  
A  B  C  D

If you think you have made a mistake, put a cross through the incorrect answer and fill in the new answer.

A  B  C  D

If you change your mind and have crossed out what you consider to be the correct answer, then indicate the correct answer by writing the word *correct* and drawing an arrow as follows.

A  B  C  D   
*correct* ↙

▶ Mark your answers for the multiple choice questions in the multiple choice grid on page 6

**Multiple Choice** (Mark your answers on the multiple choice grid on page 6)

1.

	<i>Scientist</i>	<i>Idea</i>
(A)	Davy	Oxygen is present in all acids
(B)	Lavoisier	An acid ionizes in water to produce hydrogen ions
(C)	Arrhenius	Metals can displace hydrogen from acids
(D)	Bronsted-Lowry	Acids donate protons

2. Give the systematic name for this organic compound.

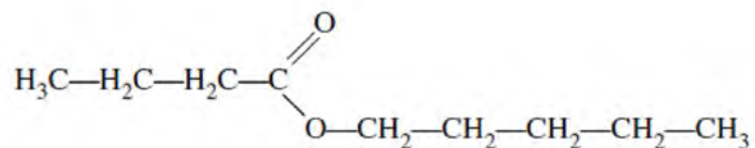

- (A) Butyl pentanoate
- (B) Pentyl butanoate
- (C) Propyl pentanoate
- (D) Pentyl propanoate
3. Which of the following chemicals would be best suited as a catalyst for esterification?
- (A) Sulfuric acid
- (B) Zeolites
- (C) Vanadium (V) oxide
- (D) Platinum
4. Which chemical would be most useful in cleaning up an acid spill in the laboratory?
- (A) vinegar
- (B) concentrated sodium hydroxide solution
- (C) sodium hydrogen carbonate
- (D) salt

5. At a particular temperature, iodine trichloride dissociates into iodine gas and chlorine gas according to the following equation:

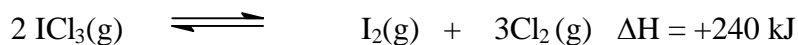

Which of the following sets of conditions would produce the highest yield of chlorine and iodine?

- (A) High temperature, low pressure
  - (B) Low temperature, high pressure
  - (C) Low temperature, low pressure
  - (D) High temperature, high pressure
6. For what purpose is an iron - based chemical required in the Haber process?
- (A) Increasing the yield of ammonia which is produced
  - (B) Increasing the activation energy of the reaction
  - (C) Increasing the quality of the ammonia which is produced
  - (D) Increasing the rate at which ammonia is produced.
7. Which of the following is a transuranic element ?
- (A) Actinium
  - (B) Americium
  - (C) Antimony
  - (D) Astatine
8. Which instrument is used to detect radiation from radioactive isotopes ?
- (A) Data logger
  - (B) pH probe
  - (C) Scintillation counter
  - (D) Ion-selective electrode

9. A student recorded some observations in a first-hand investigation :
- (i) A chilled bottle of soft drink was opened and left on a side bench.
  - (ii) Initially there was a rapid effervescence of bubbles.
  - (iii) After a lengthy period of time the bubbling ceased.

Why did the bubbling cease after a period of time ?

- (A) Air had neutralized the bubbles.
  - (B) Bubbles dissolved in the water.
  - (C) The gas was more soluble at higher temperatures and lower pressures.
  - (D) The gas was less soluble at higher temperatures and lower pressures.
10. A student measured the mass of an unopened bottle of soda water and recorded its mass to be 375.00 g. The student then opened the bottle and left it standing for 2 hours on a table top. The student then reweighed the bottle and recorded the new mass to be 372.25 g. Assuming the mass loss was due to decarbonation of the soft drink bottle, what would be the volume of carbon dioxide gas released by the soft drink at 25<sup>0</sup>C and 100 kPa ?
- (A) 0.775 L
  - (B) 1.55 L
  - (C) 3.09 L
  - (D) 7.75 L

*test continues next page...*

Student Number .....

**Part A . Answer grid for multiple choice questions**

**Total .....**

---

- |    |     |     |     |     |
|----|-----|-----|-----|-----|
| 1. | A O | B O | C O | D O |
| 2. | A O | B O | C O | D O |
| 3. | A O | B O | C O | D O |
| 4. | A O | B O | C O | D O |
| 5. | A O | B O | C O | D O |
| 6. | A O | B O | C O | D O |
| 7. | A O | B O | C O | D O |
| 8. | A O | B O | C O | D O |
| 9. | A O | B O | C O | D O |
| 10 | A O | B O | C O | D O |

*test continues next page...*

**Part B Free Response Questions - pages 7-12 (30 marks)**

*Attempt Questions 11 to 17. Allow about 45 minutes for this part.*

▶ *Show all relevant working in questions involving calculations.*

**Question 11** (4 marks)

The following graphs describe the boiling points of alkanolic acids (Series 2) and alkanols (Series 1). Explain two trends in these graphs.

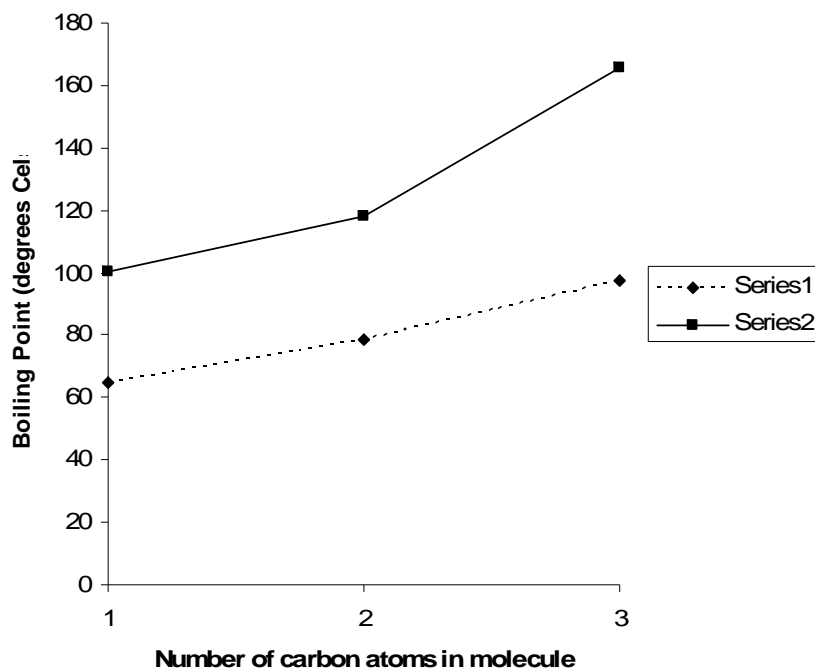

.....

.....

.....

.....

.....

.....

.....

*test continues next page...*

**Question 12** (6 marks)

Esters tend to have strong flavours and odours and are used in perfumes, cosmetics and processed foods.

- (a) Label the apparatus and processes used in the preparation of ethyl butanoate. (3 marks)

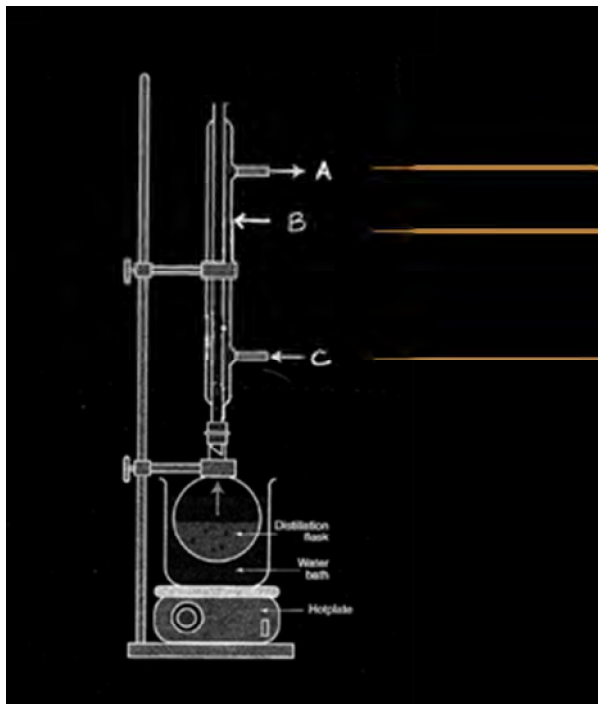

- (b) Identify the two organic reactants . (1 mark)

.....

- (c) Explain the need for refluxing during esterification. (2 marks)

.....  
.....  
.....  
.....

*test continues next page...*



**Question 13** (5 marks)

- (a) Complete the following table by identifying the salts as acidic, basic or neutral.(3 marks)

<i>salt</i>	<i>acidic, basic or neutral</i>
Ammonium chloride	
Sodium carbonate	
Calcium nitrate	
Potassium acetate	
Sodium chloride	
Potassium hydrogen carbonate	

- (b) Write a net ionic equation to show the behaviour of the acetate ion in water. (1 mark)

.....

- (c) Identify a conjugate acid/base pair in (b). (1 mark)

.....

*test continues next page...*

**Question 14** (4 marks)

Describe one example of combustion reactions, where the same reactants form different products under different conditions. Identify these conditions and include balanced chemical equations to support your answer.

.....

.....

.....

.....

.....

.....

**Question 15** (2 marks)

(a) Identify one industrial use of ammonia (1 mark)

.....

(b) Describe one reason for the close monitoring of the gas stream entering the reaction vessel in the industrial synthesis of ammonia. (1 mark)

.....

.....

.....

*test continues next page...*

**Question 16** (5 marks)

Acidic oxides have increased in concentration in the atmosphere since the 1800s. There have been some major concerns about these increases over the last 50 years.

- (a) Use a series of relevant balanced chemical equations to show the production of acid rain from industrial sources involving sulfur. (2 marks)

.....  
.....  
.....  
.....

- (b) Discuss the evidence for the concern of the increase in acid rain. (3 marks)

.....  
.....  
.....  
.....  
.....  
.....  
.....  
.....

*test continues next page...*

**Question 17** (4 marks)

Describe how commercial radioisotopes and transuranic elements are produced using specific examples of each.

.....

.....

.....

.....

.....

.....

.....

.....

 *END of Theory Test*

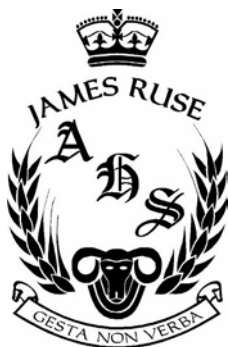

<b>Student Number</b>	
<b>Mark /</b>	

## Chemistry Assessment

### Task 2 Term 1 2010

#### Production of Materials Acidic Environment & Chemical Monitoring

## Theory

## Answers

### General Instructions

- Reading time – 5 minutes
- Working time – 55 minutes
- Write using black or blue pen
- Write your Student Number at the top of this page and on pages .....
- Board-approved calculators may be used

A data sheet and a periodic table are provided at the back of the paper.

**Total Marks – 40**

### Part A – 10 marks

- Attempt Questions **1 – 10**
- Allow about **10** minutes for this part

### Part B – 30 marks

- Attempt Questions **11 – 17**
- Allow about **45** minutes for this part

**Part A: Multiple Choice:**  
**Attempt Questions 1 – 10**  
**Allow about 10 minutes for this part**

---

Select the alternative A, B, C or D that best answers the question. Fill in the response oval completely.

**Sample:**  $2 + 4 =$  (A) 2 (B) 6 (C) 8 (D) 9  
A  B  C  D

If you think you have made a mistake, put a cross through the incorrect answer and fill in the new answer.

A  B  C  D

If you change your mind and have crossed out what you consider to be the correct answer, then indicate the correct answer by writing the word *correct* and drawing an arrow as follows.

A  B  C  D   
An arrow labeled "correct" points to the B option.

▶ Mark your answers for the multiple choice questions in the multiple choice grid on page -----

**Multiple Choice**

1. Which of the following correctly links the scientist and his idea describing acid reactions?

	<i>Scientist</i>	<i>Idea</i>
(A)	Davy	Oxygen is present in all acids
(B)	Lavoisier	An acid ionizes in water to produce hydrogen ions
(C)	Arrhenius	Metals can displace hydrogen from acids
(D)	<b>Bronsted-Lowry</b>	<b>Acids donate protons</b>

**Outcome: H8**

2. Give the systematic name for this organic compound.

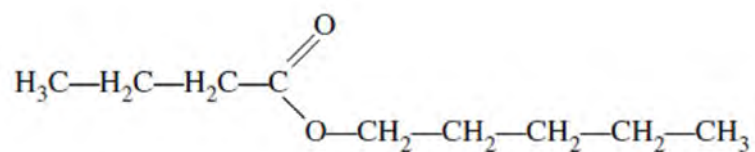

- (A) Butyl pentanoate  
(B) **Pentyl butanoate**  
(C) Propyl pentanoate  
(D) Pentyl propanoate

**Outcomes: H9**

3. Which of the following chemicals would be best suited as a catalyst for esterification?

- (A) **Sulfuric acid**  
(B) Zeolites  
(C) Vanadium (V) oxide  
(D) Platinum

**Outcomes: H8**

4. Which chemical would be most useful in cleaning up an acid spill in the laboratory?

- (A) vinegar  
(B) concentrated sodium hydroxide solution  
(C) **sodium hydrogen carbonate**  
(D) salt

**Outcomes: H4, H8**

5. At a particular temperature, iodine trichloride dissociates into iodine gas and chlorine gas according to the following equation:

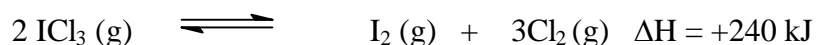

Which of the following sets of conditions would produce the highest yield of chlorine and iodine?

- (A) **High temperature, low pressure**
- (B) Low temperature, high pressure
- (C) Low temperature, low pressure
- (D) High temperature, high pressure
6. For what purpose is an iron - based chemical required in the Haber process?
- (A) Increasing the yield of ammonia which is produced
- (B) Increasing the activation energy of the reaction
- (C) Increasing the quality of the ammonia which is produced
- (D) **Increasing the rate at which ammonia is produced.**
7. Which of the following is a transuranic element?
- (A) Actinium
- (B) **Americium**
- (C) Antimony
- (D) Astatine

**Outcomes: H6**



8. Which instrument is used to detect radiation from radioactive isotopes?

- (A) Data logger
- (B) pH probe
- (C) Scintillation counter**
- (D) Ion-selective electrode

**Outcomes: H3**

9. A student recorded some observations in a first-hand investigation:

- (i) a chilled bottle of soft drink was opened and left on a side bench.
- (ii) Initially there was a rapid effervescence of bubbles.
- (iii) After a lengthy period of time the bubbling ceased.

Why did the bubbling cease after a period of time?

- (A) Air had neutralized the bubbles.
- (B) Bubbles dissolved in the water.
- (C) The gas was more soluble at higher temperatures and lower pressures.
- (D) The gas was less soluble at higher temperatures and lower pressures.**

**Outcomes: H14**

10. A student measured the mass of an unopened bottle of soda water and recorded its mass to be 375.00 g. The student then opened the bottle and left it standing for 2 hours on a table top. The student then reweighed the bottle and recorded the new mass to be 372.25 g. Assuming the mass loss was due to decarbonation of the soft drink bottle, what would be the volume of carbon dioxide gas released by the soft drink at 25<sup>0</sup>C and 100 kPa ?

- (A) 0.775 L
- (B) 1.55 L**
- (C) 3.09 L
- (D) 7.75 L

Student Number .....

**Part A . Answer grid for multiple choice questions**

**Total .....**

---

- |    |     |     |     |     |
|----|-----|-----|-----|-----|
| 1. | A O | B O | C O | D ● |
| 2. | A O | B ● | C O | D O |
| 3. | A ● | B O | C O | D O |
| 4. | A O | B O | C ● | D O |
| 5. | A ● | B O | C O | D O |
| 6. | A O | B O | C O | D ● |
| 7. | A O | B ● | C O | D O |
| 8. | A O | B O | C ● | D O |
| 9. | A O | B O | C O | D ● |
| 10 | A O | B ● | C O | D O |

## Part B Free Response Questions – pages 7 – 12 (30 marks)

Attempt Questions 11-17 .Allow about 55 minutes for this part

► Show all relevant working in questions involving calculations.

---

### Question 11 (4 marks)

The following graphs describe the boiling points of alkanolic acids (Series 2) and alkanols (Series 1). Explain two trends in these graphs.

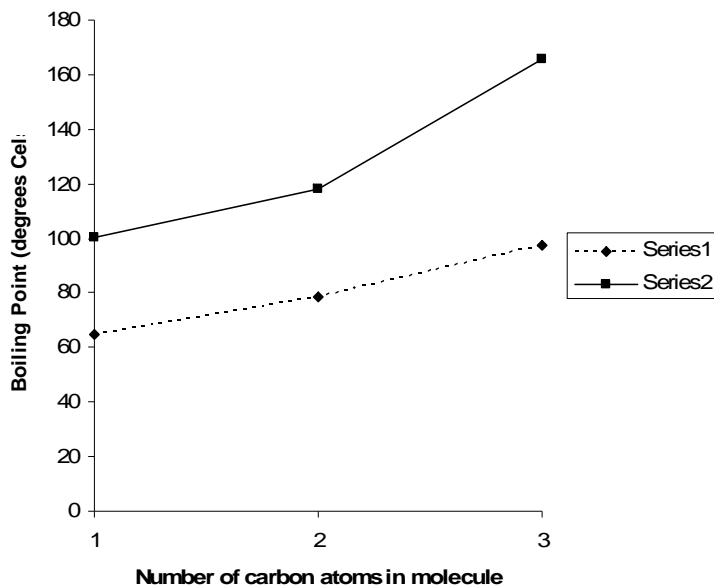

#### Sample answer

*Alkanoic acids have higher boiling points than their corresponding alkanols because there is more hydrogen bonding between alkanoic acid molecules.*

*Boiling points increase with increasing molecular mass for both alkanols and alkanoic acids because there are greater dispersion forces as molecular mass increases.*

Marking criteria	Marks
<ul style="list-style-type: none"><li>Explains two trends</li></ul>	4
<ul style="list-style-type: none"><li>Identifies one trend and explains the other trend</li></ul>	3
<ul style="list-style-type: none"><li>Identifies two trends OR</li><li>Explains one trend</li></ul>	2
<ul style="list-style-type: none"><li>Identifies one trend</li></ul>	1

**Outcomes : H9, H6**

**Question 12** (6 marks)

Esters tend to have strong flavours and odours and are used in perfumes, cosmetics and processed foods.

- (a) Label the apparatus and processes used in the preparation of ethyl butanoate. (3 marks)

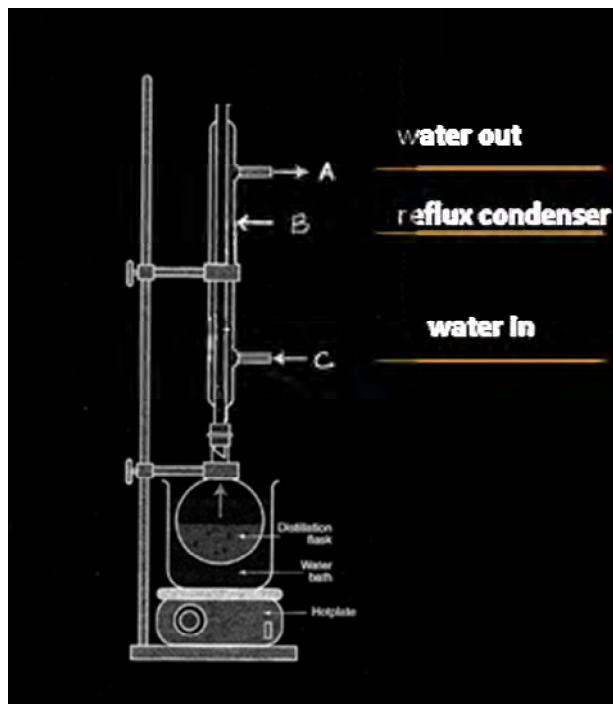

- (b) Identify the two organic reactants in the distillation flask. (1 mark)

*Ethanol and butanoic acid*

- (c) Explain the need for refluxing during esterification. (2 marks)

**Sample answer**

*Refluxing causes the condensation of volatile reactants and products and returns them to the distillation flask thus preventing them from escaping to the atmosphere. Refluxing also allows the esterification to proceed at a higher temperature which increases reaction rate.*

<i>Marking criteria</i>	<i>Marks</i>
<ul style="list-style-type: none"><li><i>Explains two reasons</i></li></ul>	<i>2</i>
<ul style="list-style-type: none"><li><i>Explains one reason or identifies two reasons</i></li></ul>	<i>1</i>

**Outcomes : H9, H11**

**Question 13** (5 marks)

- (a) Complete the following table by identifying the salts as acidic, basic or neutral.(3 marks)

*Sample answers*

salt	acidic, basic or neutral
Ammonium chloride	<i>acidic</i>
Sodium carbonate	<i>basic</i>
Calcium nitrate	<i>neutral</i>
Potassium acetate	<i>basic</i>
Sodium chloride	<i>neutral</i>
potassium hydrogen carbonate	<i>basic</i>

<i>Marking criteria</i>	<i>Marks</i>
<ul style="list-style-type: none"><li>• 6 correct answers</li></ul>	3
<ul style="list-style-type: none"><li>• 4 or 5 correct answers</li></ul>	2
<ul style="list-style-type: none"><li>• 2 or 3 correct answers</li></ul>	1

- (b) Write a balanced chemical equation to show the behaviour of the acetate ion in water. (1 mark)

*Answer(s)*

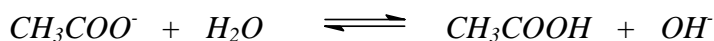

- (c) Identify a conjugate acid/base pair in your reaction. (1 mark)

*Answer(s)*

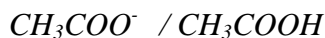

**Outcomes : H8, H9**

**Question 14** (4 marks)

Describe one example of combustion reactions, where the same reactants form different products under different conditions. Identify these conditions and include balanced chemical equations to support your answer.

**Answer:**

*A combustion reaction of a hydrocarbon can produce carbon dioxide and water or a mixture of carbon dioxide, carbon monoxide and carbon depending on the amount of oxygen available.*

**For example:**

*In plentiful supply of oxygen, octane can burn completely to form carbon dioxide and water.*

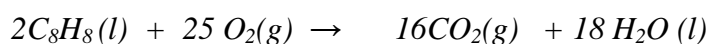

*Incomplete combustion occurs when there is insufficient oxygen*

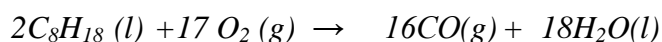
**Marking Criteria- outcome H9**

<b>Marks</b>	<b>Criteria</b>
4	At least 2 examples of combustion reactions The differing conditions for each reaction 2 correctly balanced chemical equations
3	3 of the above
2	2 of the above
1	1 of the above

**Question 15** (2 marks)

- (a) Identify one industrial use of ammonia (1 mark)

*Answer: manufacture of fertilisers, production of nitric acid, explosives*

- (b) Describe one reason for the close monitoring of the gas stream entering the reaction vessel in the industrial synthesis of ammonia. (1 mark)

**Answer:**

*To maintain the 3:1 stoichiometric ratio of hydrogen : nitrogen, to prevent an excess of either in the chamber,*

*To ensure no oxygen is present, to avoid explosion with hydrogen*

*To ensure no sulfur compounds are present, to avoid inactivating the catalyst*

### Marking Criteria- outcome H11

Marks	Criteria
2	One use correctly stated One reason for monitoring described
1	One of the above

#### Question 16 (5 marks)

Acidic oxides have increased in concentration in the atmosphere since the 1800s. There have been some major concerns about these increases over the last 50 years.

- (a) Use a series of relevant balanced chemical equations to show the production of acid rain from industrial sources involving sulfur. (2 marks)

#### Marking Criteria

Criteria	Mark(s)
Two equations correctly balanced showing the formation of acid rain	2
One equation missing	1

#### Sample Answer

#### Equations showing the formation of acid rain

- $S(s) + O_2(g) \rightarrow SO_2(g)$
- $SO_2(g) + H_2O(l) \rightarrow H_2SO_3(aq)$
- $2H_2SO_3(aq) + O_2(g) \rightarrow 2H_2SO_4(aq)$

- (b) Discuss the evidence for the concern of the increase in acid rain. (3 marks)

#### 3b. Marking Criteria

Criteria	Mark
Thorough discussion of the evidence present causing concern of the formation of acid rain.	3
Brief description of the formation and effects of acid rain	2
One effect of acid rain	1

#### Sample Answer :

*There is a major concern about the increasing concentrations of oxides of sulfur in the atmosphere due to the increased sulfur dioxide emissions from the burning of coal and smelting of metal ores. This build up causes the formation of acid rain.*

*Acid rain reacts with marble and limestone buildings and structures destroying many historical structures. Steel structures also indicate corrosion at a fast rate due to the presence of acid rain. There is also evidence of aquatic life destruction as a result of decreasing pH(increasing acidity) in rivers, lakes and streams.*

**Question 17** (4 marks)

Describe how commercial radioisotopes and transuranic elements are produced using specific examples of each. (4 marks)

**Outcomes: H3, H6**

**Marking criteria**

<i>Criteria</i>	<i>Mark(s)</i>
Description for both the production of transuranic elements and commercial radioisotopes with appropriate examples of each.	4
One of the above missing	3
Two of the above missing	2
Three of the above missing	1

*Sample Answer:*

*Both are produced synthetically in nuclear reactors and cyclotrons by bombardment with neutrons or with charged particles usually the nuclei of other atoms. The transuranic elements are those following uranium in the periodic table thus heavier than uranium*

*e.g. correct examples*

*The transuranic elements disintegrate quickly after production in the reactors.*

*Commercial radioisotopes are used in industry, medicine and research. The nuclei of stable elements are bombarded with neutrons which are absorbed and the nucleus is transformed into a radioactive nucleus.*

*E.g. correct example.*

*END of Theory Test*