



Girraween High School

2020 Year 12 Mathematics Advanced

General Instructions

- Reading Time - 10 minutes
 - Working Time - 3 hours
 - Write using black pen only
 - Calculators approved by NESA may be used
 - For questions in Section II, Show relevant mathematics reasoning and/ or calculations
-

Total Marks:

100

Section I - 10 marks (pages 1-4)

- Attempt questions 1-10
- Allow about 15 minutes for this section

Section II - 90 marks (pages 6-26)

- Attempt questions 11-38
- Allow about 2 hours and 45 minutes for this section

Question 1 (1 mark)

What type of a relation is shown?

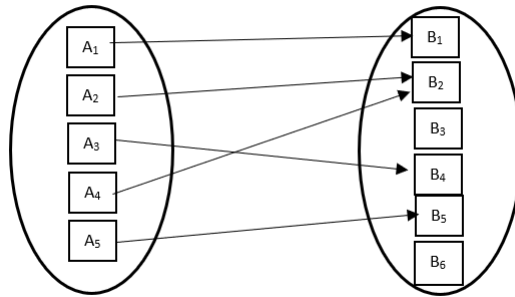

- A. Many-to-many
- B. One-to-many
- C. One-to-one
- D. Many-to-one

Question 2 (1 mark)

The graph shows the velocity of a particle, v metres per second, as a function of time, t seconds.

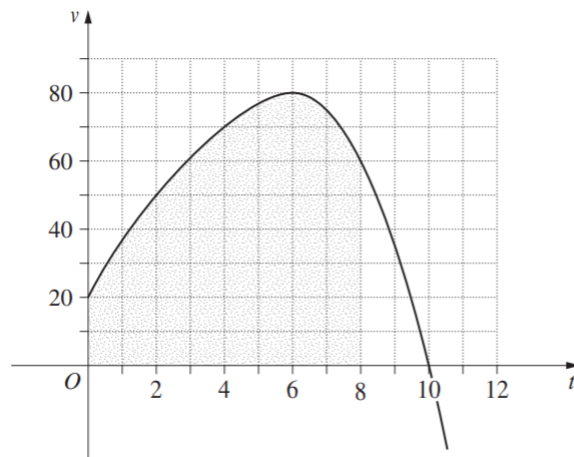

When is the acceleration of the particle equal to zero?

- A. $t = 0$
- B. $t = 10$
- C. $t = 6$
- D. $t = 8$

Question 3 (1 mark)

For events A and B , $P(A|B) = \frac{2}{5}$ and $P(B|A) = \frac{1}{3}$. Let $P(A \cap B) = p$.
What is the value of $P(A)$?

- A. $3p$
- B. p
- C. $\frac{1}{3}p$
- D. $\frac{2}{5}p$

Question 4 (1 mark)

$(\sqrt{3} - 1)(2\sqrt{3} + 5)$ simplifies to:

- A. $11 + 7\sqrt{3}$
- B. $11 + 3\sqrt{3}$
- C. $1 + 3\sqrt{3}$
- D. $1 - 3\sqrt{3}$

Question 5 (1 mark)

What are the values of x for which $|4x - 3| = 7$.

- A. $x = 2\frac{1}{2}$ and $x = -1$
- B. $x = 2\frac{1}{2}$ and $x = 1$
- C. $x = -2\frac{1}{2}$ and $x = -1$
- D. $x = -2\frac{1}{2}$ and $x = 1$

Question 6 (1 mark)

The population N of a town, after t years, is given by the formula $N = N_0 e^{0.04t}$, where N_0 is the initial population. Which expression represents the number of years it takes until the town has doubled its population?

- A. $\frac{2 \log_e 100}{5}$
- B. $4 \log_e 2$
- C. $2 \log_e 25$
- D. $25 \log_e 2$

Question 7 (1 mark)

$$\int \tan^2 x \, dx =$$

- A. $\sec^2 x + c$
- B. $2 \tan x + c$
- C. $\tan x - x + c$
- D. $2 \tan x - x + c$

Question 8 (1 mark)

Let M be the mid point of $(-1, 4)$ and $(5, 8)$. Then, the equation of line through M with gradient $\frac{-1}{2}$ is:

- A. $x + 2y - 10 = 0$
- B. $x + 2y - 14 = 0$
- C. $2x + y - 10 = 0$
- D. $2x - y - 14 = 0$

Question 9 (1 mark)

Given the function $y = e^{\sqrt{x}}$, which expression is equal to $\frac{dy}{dx}$?

- A. $e^{\sqrt{x}}$
- B. $e \frac{\sqrt{x}}{x}$
- C. $\frac{e^{\sqrt{x}}}{2\sqrt{x}}$
- D. $\frac{e^{\sqrt{x}}}{\sqrt{x}}$

Question 10 (1 mark)

A company collected data on the reasons for given by 200 factory workers for arriving late. The pareto chart shows the data collected.

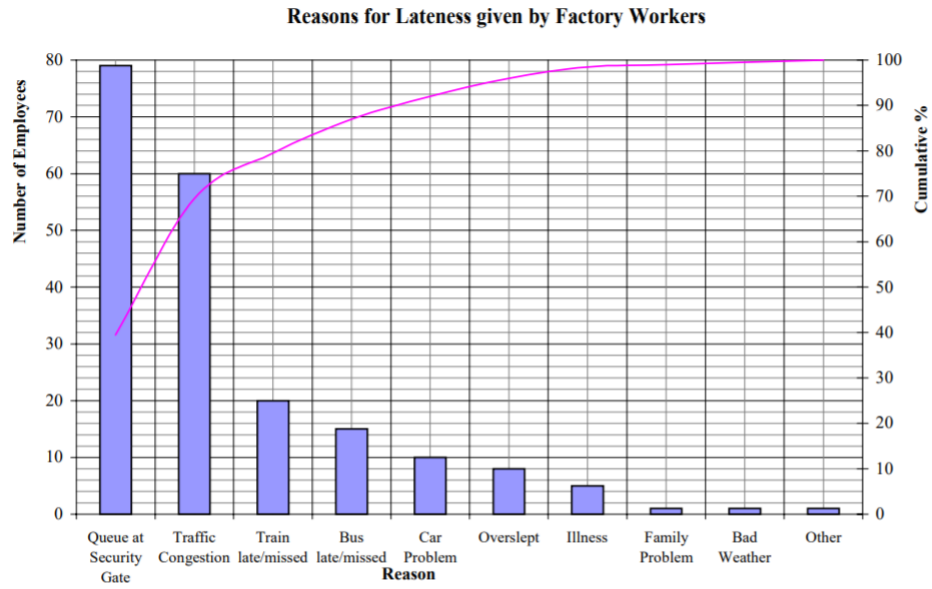

What percentage of workers gave the reason "Traffic congestion"?

- A. 60%
- B. 75%
- C. 50%
- D. 30%

Mathematics Advanced
Section II Answer Booklet

90 Marks

Attempt Questions 11-38

Allow about 2 hours and 45 minutes for this section

Instructions

- Answer the questions in the spaces provided.
- Your responses should include relevant mathematics reasoning and/ or calculations

Please turn over

Question 11 (2 marks)

Find the equation of the tangent to the curve $y = \sqrt{x}$ at $x = 9$.

.....

.....

.....

.....

.....

.....

.....

.....

.....

.....

.....

Question 12 (3 marks)

The diagram shows a triangle with sides of length 9cm , $x\text{cm}$ and 7cm and the angle of 47° .

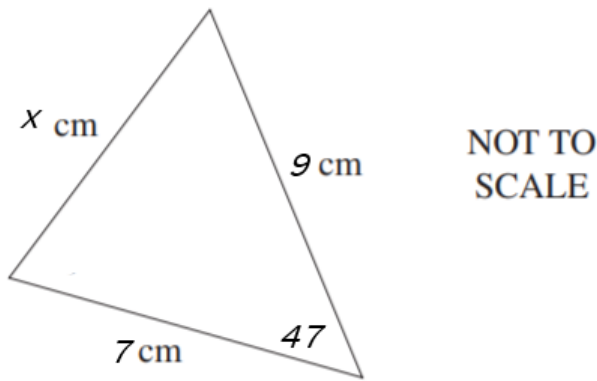

Use the cosine rule to calculate the value of x , correct to two significant figures.

.....

.....

.....

.....

.....

.....

.....

.....

.....

.....

.....

Question 13 (2 marks)

A certain poker machine with 3 wheels has 10 fruit symbols on each wheel. The first wheel has 4 cherries on it, the second has 2 cherries on it and the third wheel has 5 cherries on it. Find

- (a) the number of arrangements which contain 3 cherries. [1 mark]

.....
.....
.....
.....
.....

- (b) the probability of obtaining 3 cherries on the viewing line. [1 mark]

.....
.....
.....
.....
.....

Question 14 (6 marks)

A function is given by $f(x) = x^3 - 3x^2 + 3x$.

- (a) Find the stationary points and determine their nature. [4 marks]

.....
.....
.....
.....
.....
.....
.....
.....
.....
.....
.....
.....
.....
.....
.....
.....
.....
.....
.....
.....
.....

(b) Sketch the curve, labelling the stationary points and axes intercepts. [2 marks]

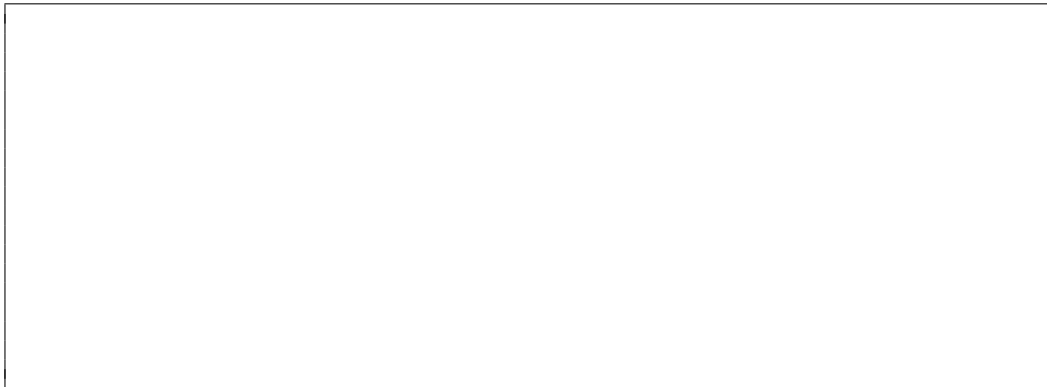

Question 15 (4 marks)

A mixture is to be made of two foods A and B . The two foods A , B contain nutrients P and Q as shown below:

Ounces per pound of nutrient

Food	P	Q
A	1	2
B	3	1

The mixture contains 8 ounces of P and 6 ounces of Q .

For example: one part of A and 3 parts of B will make 8 ounces of P i.e., $A + 3B = 8$

(a) Use the similar method to form an equation for nutrient Q . [1 mark]

.....

(b) Solve the two equations simultaneously to find the values of A and B . [3 marks]

.....
.....
.....
.....
.....
.....
.....
.....
.....
.....
.....
.....

Question 16 (2 marks)

Differentiate $y = e^{\cos 2x}$

.....
.....
.....
.....

Question 17 (2 marks)

Given the function $f(x) = x^2 + 2x$ and $g(x) = x + 1$.

Find $f(g(x))$.

.....
.....
.....
.....
.....

Question 18 (4 marks)

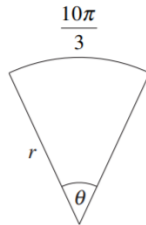

The diagram shows a sector with radius r and angle θ where $0 < \theta \leq 2\pi$. The arc length is $\frac{10\pi}{3}$.

- (a) Find the value of θ and hence, show that $r \geq \frac{5}{3}$. [2 marks]

.....
.....
.....
.....
.....
.....
.....
.....
.....
.....
.....

(b) Calculate the area of the sector when $r = 4$. [2 marks]

.....
.....
.....
.....
.....
.....
.....
.....
.....
.....
.....
.....
.....
.....

Question 19 (3 marks)

A discrete random variable X has the probability distribution table shown.

x	0	1	2	3	8
$P(X = x)$	p	$\frac{2}{5}$	$\frac{3}{20}$	$\frac{1}{4}$	p

(a) Show that $p = \frac{1}{10}$. [1 mark]

.....
.....
.....
.....
.....
.....
.....

(b) Find the mean μ . [1 mark]

.....
.....
.....
.....

Question 24 (2 marks)

The graph of a function $f(x)$ is shown.

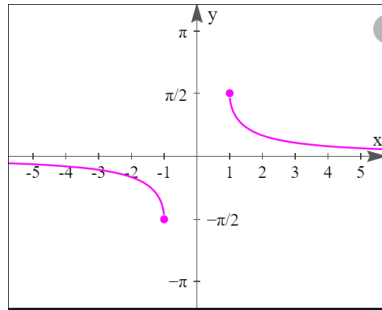

Use the interval notation, state the domain and range of $f(x)$.

.....
.....
.....
.....

Question 25 (3 marks)

(a) Sketch the graph of $y = |x - 1|$ and $y = 2x + 4$ for $-4 \leq x \leq 4$ on the grid given below.



(b) Using the sketch from part a, solve $|x - 1| = 2x + 4$

.....
.....
.....
.....
.....
.....
.....
.....

Question 26 (4 marks)

(a) Differentiate $y = xe^{3x}$. [2 marks]

.....
.....
.....
.....

(b) Hence find the exact value of $\int_0^2 e^{3x}(3 + 9x)dx$ [2 marks]

$$\int_0^2 e^{3x}(3 + 9x)dx$$

.....
.....
.....
.....
.....

Question 27 (2 marks)

The function $f(x) = |x|$ is transformed and the equation of the new function is of the form $y = kf(x + b) + c$, where k , b and c are constants. The graph of the new function is shown.

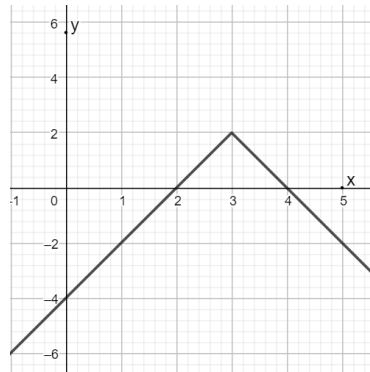

What are the values of k , b and c ?

.....
.....
.....
.....

Question 28 (4 marks)

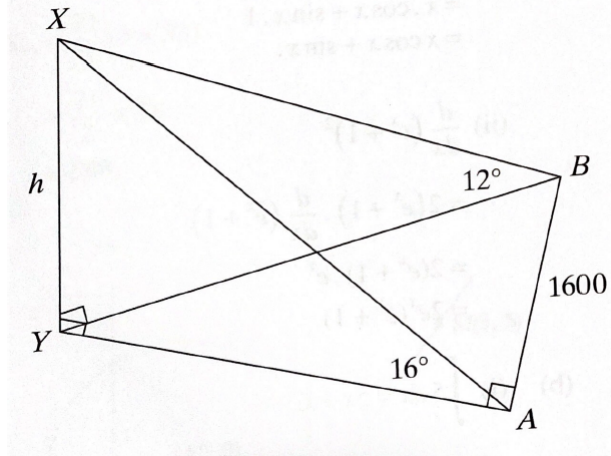

Decaln walks 1600 metres due north along a road from point A to point B .
 The point is due east of a hill XY , where X is the top of the hill.
 The point Y is directly below point X and is on the same horizontal plane as the road.
 Let the height of the hill above point Y be h metres.
 From point A , the angle of elevation to the top of the hill is 16° .
 From point B , the angle of elevation to the top of the hill is 12° .

(a) Show that $BY = h \cot 12^\circ$. [1 mark]

.....

(b) Hence, find the value of h . [3 marks]

.....

Question 29 (5 marks)

Let $y = f(x)$ be a function defined for $0 \leq x \leq 6$, with $f(0) = 0$.

The diagram shows the graph of the derivative of $f(x)$, $y = f'(x)$.

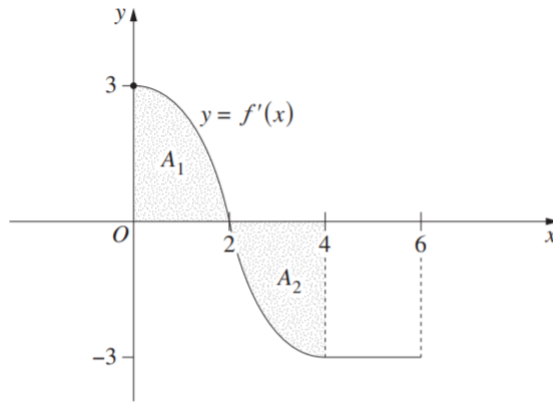

The shaded region A_1 has area 4 square units. The shaded region A_2 has area 4 square units.

(a) For what values of x is $f(x)$ increasing? [1 mark]

.....
.....

(b) What is the maximum value of $f(x)$? [1 mark]

.....
.....
.....
.....
.....
.....
.....
.....
.....
.....
.....
.....

(c) Find the value of $f(6)$. [1 mark]

.....
.....
.....
.....
.....
.....
.....
.....
.....
.....

(d) Draw a graph of $y = f(x)$ for $0 \leq x \leq 6$. [2 marks]

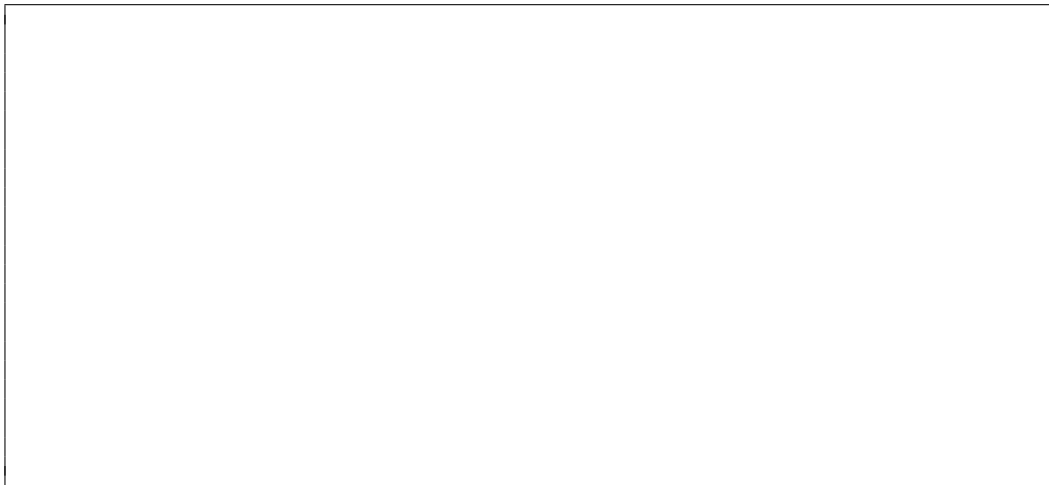

Question 31 (2 marks)

Let $f(x) = x^3 - 3x^2 + kx + 8$, where k is a constant. Find the values of k for which $f(x)$ is an increasing function.

.....
.....
.....
.....
.....
.....
.....
.....
.....
.....
.....
.....
.....
.....
.....
.....
.....
.....
.....
.....
.....

Question 32 (2 marks)

Find integers a and b such that $\frac{1}{\sqrt{5} - 2} = a + b\sqrt{5}$.

.....
.....
.....
.....
.....
.....
.....
.....
.....
.....
.....
.....
.....
.....
.....
.....
.....
.....
.....
.....
.....

Question 34 (3 marks)

Initially a car is at rest. The car then starts from a point P at time $t = 0$ seconds and comes to a stop at point Q . The distance x , in metres covered by the car, in t seconds is given by $x = t^2 \left(2 - \frac{t}{3} \right)$. Find

- (a) the time taken by it to reach Q . [2 marks]

.....
.....
.....
.....
.....
.....
.....
.....
.....
.....
.....
.....
.....
.....
.....

- (b) the distance between P and Q .

.....
.....
.....
.....
.....
.....
.....
.....
.....
.....
.....
.....
.....
.....
.....

Question 35 (5 marks)

The diagram shows the curve with equation $y = x^2 - 7x + 10$. The curve intersects the x -axis at points A and B . The point C on the curve has the same y -coordinate as the y -intercept of the curve.

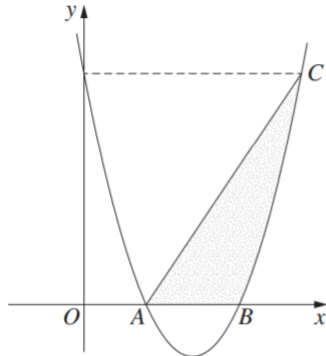

(a) Find the x -coordinates of Points A and B . [1 mark]

.....
.....
.....
.....
.....
.....
.....
.....
.....
.....

(b) Write down the coordinates of C . [1 mark]

.....
.....
.....
.....
.....
.....
.....
.....
.....
.....

(c) Evaluate [1 mark]

$$\int_0^2 (x^2 - 7x + 10)dx$$

.....
.....
.....
.....
.....
.....
.....
.....
.....
.....
.....
.....
.....
.....
.....
.....
.....
.....
.....
.....
.....

(d) Hence, or otherwise, find the area of the shaded region. [2 marks]

.....
.....
.....
.....
.....
.....
.....
.....
.....
.....
.....
.....
.....
.....
.....
.....
.....
.....
.....
.....
.....

Question 36 (5 marks)

(a) A simple musical instrument has many strings. The difference between the lengths of adjacent strings is constant, so that the lengths of the strings are the terms of an arithmetics series. The shortest string is 30 cm long and the longest string is 48 cm . The sum of the lengths of all the strings is 1209 cm .

i. Find the number of strings.[2 marks]

.....
.....
.....
.....
.....
.....
.....
.....

ii. Find the difference in length between adjacent strings. [1 mark]

.....
.....
.....
.....
.....
.....
.....

(b) There is a large sheet of paper which is 0.1 mm thick that is cut in half. Then one piece is placed on top of the other. This pile is again cut in half and one pile is placed on top of the other. This process is repeated 40 times. How high is the pile of the sheets? [2 marks]

.....
.....
.....
.....
.....
.....
.....
.....

Question 37 (4 marks)

(a) The function $f(x) = \sin x$ is transformed to $g(x) = 3\sin 2x$.

Describe in words how both the amplitude and period change in this transformation.

[2 marks]

.....

.....

.....

.....

.....

.....

.....

.....

.....

.....

.....

.....

(b) Sketch $\frac{1}{x^2 - 49}$ clearly showing asymptotes and intercepts. [2 marks]

Question 38 (6 marks)

- (a) Use trapezoidal rule with three function values to find an approximation to

$$\int_1^3 \ln x \, dx$$

[3 marks]

.....
.....
.....
.....
.....
.....
.....
.....
.....
.....
.....
.....
.....
.....

- (b) State whether the approximation found in the previous part is greater than or lesser than exact value of $\int_1^3 \ln x \, dx$. Justify your answer by sketching the curve $y = \ln x$
[3 marks]

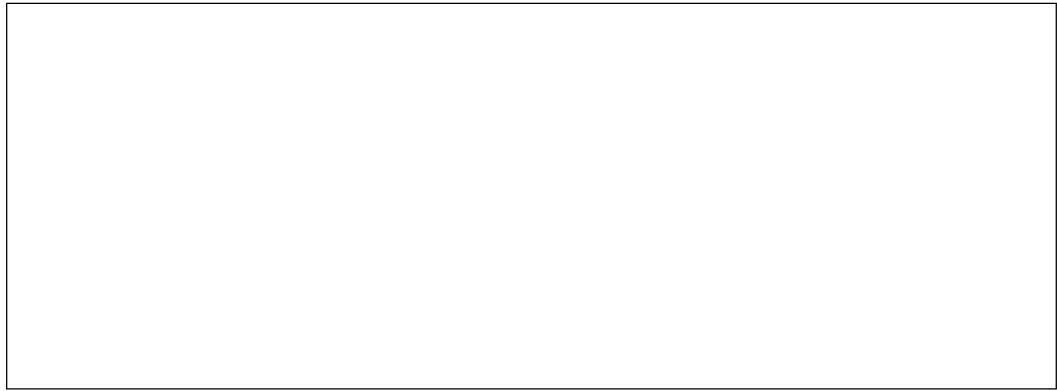

.....
.....
.....
.....

End of exam



Girraween High School

2020 Year 12 Mathematics Advanced: Solutions

Section I - 10 marks (pages 1-4)

- Attempt questions 1-10
- Allow about 15 minutes for this section

Section II - 90 marks (pages 6-26)

- Attempt questions 11-38
- Allow about 2 hours and 45 minutes for this section

Multiple Choice Answers:

1	2	3	4	5	6	7	8	9	10
D	C	A	C	A	D	C	B	C	D

Question 1 (1 mark)

What type of a relation is shown?

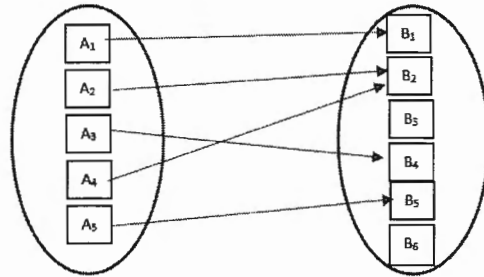

$a_2 \neq a_4$ but
 $f(a_2) = f(a_4)$
 $\therefore f$ is a many-to-one
function

- A. Many-to-many
- B. One-to-many
- C. One-to-one
- D. Many-to-one

Question 2 (1 mark)

The graph shows the velocity of a particle, v metres per second, as a function of time, t seconds.

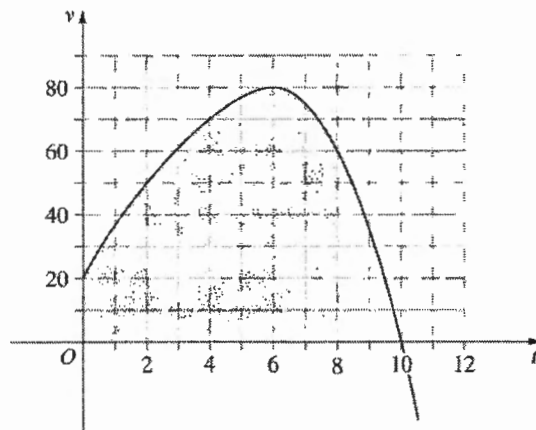

When is the acceleration of the particle equal to zero?

- A. $t = 0$
- B. $t = 10$
- C. $t = 6$
- D. $t = 8$

Question 3 (1 mark)

For events A and B , $P(A|B) = \frac{2}{5}$ and $P(B|A) = \frac{1}{3}$. Let $P(A \cap B) = p$.
What is the value of $P(A)$?

A. $3p$

B. p

C. $\frac{1}{3}p$

D. $\frac{2}{5}p$

$$P(B|A) = \frac{1}{3}; \quad P(A \cap B) = p$$

$$P(B|A) = \frac{P(B \cap A)}{P(A)}$$

$$\frac{1}{3} = \frac{p}{P(A)} \longrightarrow \therefore P(A) = 3p$$

Question 4 (1 mark)

$(\sqrt{3} - 1)(2\sqrt{3} + 5)$ simplifies to:

A. $11 + 7\sqrt{3}$

B. $11 + 3\sqrt{3}$

C. $1 + 3\sqrt{3}$

D. $1 - 3\sqrt{3}$

$$\sqrt{3}(2\sqrt{3} + 5) - 1(2\sqrt{3} + 5)$$

$$= 6 + 5\sqrt{3} - 2\sqrt{3} - 5$$

$$= 1 + 3\sqrt{3}$$

Question 5 (1 mark)

What are the values of x for which $|4x - 3| = 7$.

A. $x = 2\frac{1}{2}$ and $x = -1$

B. $x = 2\frac{1}{2}$ and $x = 1$

C. $x = -2\frac{1}{2}$ and $x = -1$

D. $x = -2\frac{1}{2}$ and $x = 1$

$$4x - 3 = 7$$

$$x = 2\frac{1}{2}$$

$$4x - 3 = -7$$

$$x = -1$$

Question 6 (1 mark)

The population N of a town, after t years, is given by the formula $N = N_0 e^{0.04t}$, where N_0 is the initial population. Which expression represents the number of years it takes until the town has doubled its population?

A. $\frac{2 \log_e 100}{5}$

B. $4 \log_e 2$

C. $2 \log_e 25$

D. $25 \log_e 2$

$$N = N_0 e^{0.04t}$$

$$2N_0 = N_0 e^{0.04t}$$

$$t = \frac{\ln 2}{0.04}$$

$$t = 25 \log_e 2$$

Question 7 (1 mark)

$$\int \tan^2 x \, dx =$$

- A. $\sec^2 x + c$
- B. $2 \tan x + c$
- C. $\tan x - x + c$
- D. $2 \tan x - x + c$

$$\begin{aligned} \int \tan^2 x \, dx &= \int (\sec^2 x - 1) \, dx \\ &= \tan x - x + c \end{aligned}$$

Question 8 (1 mark)

Let M be the mid point of $(-1, 4)$ and $(5, 8)$. Then, the equation of line through M with gradient $-\frac{1}{2}$ is:

- A. $x + 2y - 10 = 0$
- B. $x + 2y - 14 = 0$
- C. $2x + y - 10 = 0$
- D. $2x - y - 14 = 0$

$$\begin{aligned} M(2, 6) \\ y - 6 &= -\frac{1}{2}(x - 2) \\ 2y - 12 &= -x + 2 \\ x + 2y - 14 &= 0 \end{aligned}$$

Question 9 (1 mark)

Given the function $y = e^{\sqrt{x}}$, which expression is equal to $\frac{dy}{dx}$?

- A. $e^{\sqrt{x}}$
- B. $e \frac{\sqrt{x}}{x}$
- C. $\frac{e^{\sqrt{x}}}{2\sqrt{x}}$
- D. $\frac{e^{\sqrt{x}}}{\sqrt{x}}$

Question 10 (1 mark)

A company collected data on the reasons for given by 200 factory workers for arriving late. The pareto chart shows the data collected.

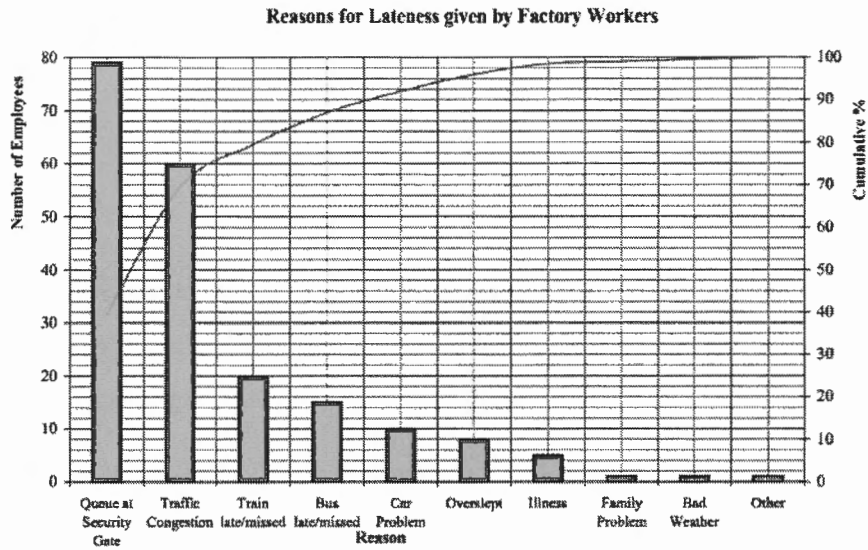

What percentage of workers gave the reason "Traffic congestion"?

- A. 60%
- B. 75%
- C. 50%
- D. 30%

$$\begin{aligned} \text{Total} &= 200 ; \text{Traffic} = 60 \\ &= \frac{60 \times 100}{200} \\ &= 30\% \end{aligned}$$

Question 11 (2 marks)

Find the equation of the tangent to the curve $y = \sqrt{x}$ at $x = 9$.

$$y = \sqrt{x} \quad ; \quad y' = \frac{1}{2\sqrt{x}}$$

Gradient of the tangent at $x = 9$

$$m = \frac{1}{2\sqrt{9}} = \frac{1}{6}$$

Equation of the tangent (9, 3)

$$y - 3 = \frac{1}{6}(x - 9) \quad \left| \quad x - 6y + 9 = 0\right.$$
$$6y - 18 = x - 9$$

Question 12 (3 marks)

The diagram shows a triangle with sides of length 9cm, x cm and 7cm and the angle of 47° .

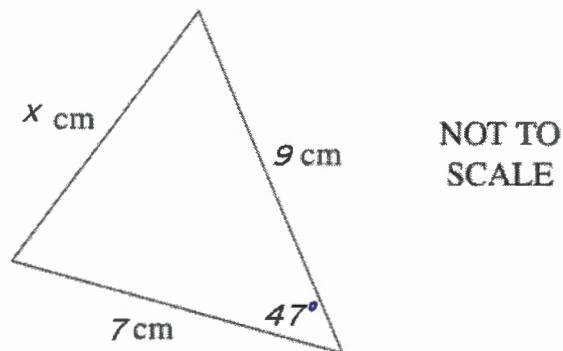

Use the cosine rule to calculate the value of x , correct to two significant figures.

$$x^2 = 9^2 + 7^2 - 2 \times 9 \times 7 \cos 47^\circ$$
$$x = 6.6 \text{ cm.}$$

Question 13 (2 marks)

A certain poker machine with 3 wheels has 10 fruit symbols on each wheel. The first wheel has 4 cherries on it, the second has 2 cherries on it and the third wheel has 5 cherries on it. Find

- (a) the number of arrangements which contain 3 cherries. [1 mark]

$$4 \times 2 \times 5 = 40$$

- (b) the probability of obtaining 3 cherries on the viewing line. [1 mark]

$$\frac{40}{1000} \text{ or } \left(\frac{4}{10} \times \frac{2}{10} \times \frac{5}{10} \right)$$
$$= \frac{1}{25}$$

Question 14 (6 marks)

A function is given by $f(x) = x^3 - 3x^2 + 3x$.

- (a) Find the stationary points and determine their nature. [4 marks]

$$f(x) = x^3 - 3x^2 + 3x$$

$$f'(x) = 3x^2 - 6x + 3$$

$$f''(x) = 6x - 6$$

Finding stationary points

$$f'(x) = 0$$

$$3x^2 - 6x + 3 = 0$$

$$x^2 - 2x + 1 = 0$$

$$(x-1)^2 = 0$$

$$x = 1$$

Determining the nature
Sub $x=1$ in $f''(x)$

$$f''(1) = 6(1) - 6 = 0$$

Checking concavity

x	0	1	2
$f''(x)$	-6	0	12

Concavity changes
at $x=1$; $y=1$

\therefore There is a horizontal
point of inflexion
at $(1, 1)$

(b) Sketch the curve, labelling the stationary points and axes intercepts. [2 marks]

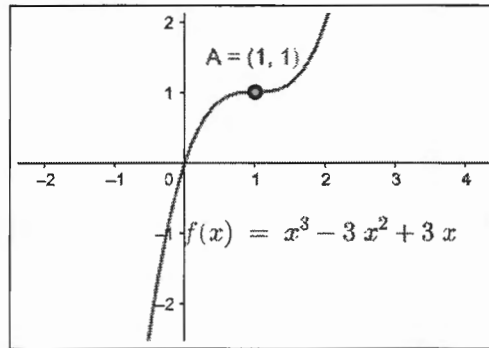

Question 15 (4 marks)

A mixture is to be made of two foods A and B . The two foods A, B contain nutrients P and Q as shown below:

Ounces per pound of nutrient

Food	P	Q
A	1	2
B	3	1

The mixture contains 8 ounces of P and 6 ounces of Q .

For example: one part of A and 3 parts of B will make 8 ounces of P i.e., $A + 3B = 8$

(a) Use the similar method to form an equation for nutrient Q . [1 mark]

..... $2A + B = 6$

(b) Solve the two equations simultaneously to find the values of A and B . [3 marks]

$A + 3B = 8 \quad \text{--- (1) } \times 2$ $2A + B = 6 \quad \text{--- (2)}$ $2A + 6B = 16$ $\underline{(-) 2A + B = 6}$ $5B = 10$ $\underline{\hspace{2cm}}$ $B = 2$ <p>Sub $B = 2$ in (2)</p> $2A + 2 = 6$	$2A = 4$ $A = 2$ $\therefore A = 2 \text{ and } B = 2$
--	--

Question 16 (2 marks)

Differentiate $y = e^{\cos 2x}$

$$\frac{dy}{dx} = -2 \sin 2x e^{\cos 2x}$$

Question 17 (2 marks)

Given the function $f(x) = x^2 + 2x$ and $g(x) = x + 1$.

Find $f(g(x))$.

$$\begin{aligned} f(g(x)) &= f(x+1) = (x+1)^2 + 2(x+1) \\ &= x^2 + 2x + 1 + 2x + 2 \\ &= x^2 + 4x + 3 \end{aligned}$$

Question 18 (4 marks)

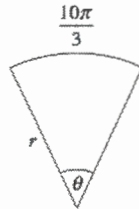

The diagram shows a sector with radius r and angle θ where $0 < \theta \leq 2\pi$. The arc length is $\frac{10\pi}{3}$.

(a) Find the value of θ and hence, show that $r \geq \frac{5}{3}$. [2 marks]

$$\begin{aligned} l &= r\theta \text{ where } 0 < \theta \leq 2\pi \\ \therefore \frac{10\pi}{3} &= r\theta \\ \theta &= \frac{10\pi}{3r} \end{aligned}$$

Now $0 < \theta \leq 2\pi$

$$\begin{aligned} 0 < \frac{10\pi}{3r} &\leq 2\pi \\ 0 < 10\pi &\leq (2\pi \times 3r) \\ 0 < \frac{10\pi}{2\pi} &\leq 3r \end{aligned}$$
$$\begin{aligned} 0 < \frac{5}{3} &\leq r \\ \therefore r &> \frac{5}{3} \end{aligned}$$

(b) Calculate the area of the sector when $r = 4$. [2 marks]

$$A = \frac{1}{2} r^2 \theta \quad \text{where } \theta = \frac{10\pi}{3r} \quad \text{and } r = 4$$
$$A = \frac{1}{2} \times 4^2 \times \frac{10\pi}{3 \times 4}$$
$$= \frac{1}{2} \times 16 \times \frac{10\pi}{12}$$
$$= \frac{80\pi}{12}$$
$$= \frac{20\pi}{3}$$

\therefore Area of sector is $\frac{20\pi}{3}$ sq units

Question 19 (3 marks)

A discrete random variable X has the probability distribution table shown.

x	0	1	2	3	8
$P(X = x)$	p	$\frac{2}{5}$	$\frac{3}{20}$	$\frac{1}{4}$	p

(a) Show that $p = \frac{1}{10}$. [1 mark]

$$p + \frac{2}{5} + \frac{3}{20} + \frac{1}{4} + p = 1$$
$$2p + \frac{4}{5} = 1$$
$$2p = \frac{1}{5}$$
$$p = \frac{1}{10}$$

(b) Find the mean μ . [1 mark]

Ans on Next page

$$M = 0\left(\frac{1}{10}\right) + 1\left(\frac{2}{5}\right) + 2\left(\frac{3}{20}\right) + 3\left(\frac{1}{4}\right) + 8\left(\frac{1}{10}\right)$$

$$= 2\frac{1}{4}$$

(c) What is $P(X < \mu)$? [1 mark]

$$P(X < \mu) = P\left(X < 2\frac{1}{4}\right)$$

$$= P(X=0) + P(X=1) + P(X=2)$$

$$= \frac{1}{10} + \frac{2}{5} + \frac{3}{20} = \frac{13}{20}$$

Question 20 (2 marks)

The function $f(x) = \sin^2(2x + 1)$ is given. If $f'(x) = m \cos(2x + 1) \sin(2x + 1)$. Find the value of m .

$$f(x) = \sin^2(2x + 1)$$

$$f'(x) = 4 \cos(2x + 1) \sin(2x + 1)$$

Given $f'(x) = m \cos(2x + 1) \sin(2x + 1)$

$$\therefore m \cos(2x + 1) \sin(2x + 1) = 4 \cos(2x + 1) \sin(2x + 1)$$

By comparing the coefficients

$$m = 4$$

Question 21 (2 marks)

A circle is given by the equation $x^2 + y^2 - 6x + 2y = 6$. Find the centre and radius of the circle.

$$x^2 + y^2 - 6x + 2y = 6$$

Rewriting and using completing the squares

$$x^2 - 6x + 9 + y^2 + 2y + 1 = 6 + 9 + 1$$

$$(x - 3)^2 + (y + 1)^2 = 16$$

\therefore Centre $(3, -1)$ and radius $= 4$

Question 22 (2 marks)

Given $f(x) = x^2 - 6x + 8$ Differentiate $f(x)$ using first principles. [2 marks]

$$\begin{aligned} f(x) &= x^2 - 6x + 8 \\ f(x+h) &= (x+h)^2 - 6(x+h) + 8 = x^2 + 2xh + h^2 - 6x - 6h + 8 \\ f(x+h) - f(x) &= \cancel{x^2} + 2xh + h^2 - 6\cancel{x} - 6h + \cancel{8} - \cancel{x^2} + \cancel{6x} - \cancel{8} \\ f(x+h) - f(x) &= 2hx - 6h + h^2 \\ \text{Differentiating using first principles} \\ f'(x) &= \lim_{h \rightarrow 0} \frac{f(x+h) - f(x)}{h} \\ f'(x) &= \lim_{h \rightarrow 0} \frac{2hx - 6h + h^2}{h} \\ f'(x) &= \lim_{h \rightarrow 0} (2x - 6 + h) = \underline{\underline{2x - 6}} \end{aligned}$$

Question 23 (2 marks)

The gradient function of a curve $y = f(x)$ is given by $f'(x) = 4x - 5$. The curve passes through the point (2, 3).

Find the equation of the curve.

$$\begin{aligned} f(x) &= \int f'(x) dx \\ f(x) &= \int (4x - 5) dx \\ f(x) &= \frac{4x^2}{2} - 5x + C \\ f(x) &= 2x^2 - 5x + C \\ \text{Given } f(x) \text{ passes through} \\ &\text{(2, 3)} \\ 3 &= 2(2)^2 - 5(2) + C \\ 3 &= 8 - 10 + C \\ \therefore C &= 5 \\ \therefore f(x) &= 2x^2 - 5x + 5 \\ &\text{is the equation of} \\ &\text{the curve.} \end{aligned}$$

Question 24 (2 marks)

The graph of a function $f(x)$ is shown.

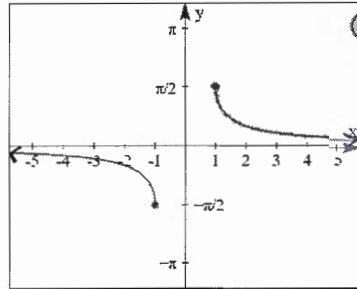

Use the interval notation, state the domain and range of $f(x)$.

Domain: $(-\infty, -1] \cup [1, \infty)$
Range: $[-\frac{\pi}{2}, 0) \cup (0, \frac{\pi}{2}]$

Question 25 (3 marks)

- (a) Sketch the graph of $y = |x - 1|$ and $y = 2x + 4$ for $-4 \leq x \leq 4$ on the grid given below.

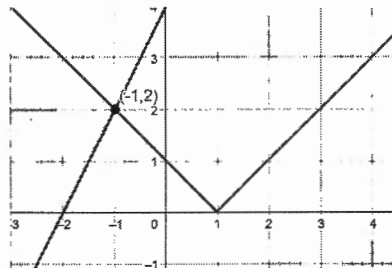

- (b) Using the sketch from part a, solve $|x - 1| = 2x + 4$

Point of intersection $(-1, 2)$
 \therefore solution $x = -1$

Question 26 (4 marks)

(a) Differentiate $y = xe^{3x}$. [2 marks]

$$\begin{aligned} \text{Using product rule: } y' &= u'v + uv' \\ y &= xe^{3x} \\ y' &= e^{3x} + 3xe^{3x} \\ y' &= e^{3x}(1+3x) \end{aligned}$$

(b) Hence find the exact value of $\int_0^2 e^{3x}(3+9x)dx$ [2 marks]

$$\int_0^2 e^{3x}(3+9x)dx$$

$$\begin{aligned} \int_0^2 e^{3x}(3+9x)dx &= \int_0^2 e^{3x} \times 3 \times (1+3x)dx \\ &= 3 \int_0^2 e^{3x}(1+3x)dx \\ &= 3 [xe^{3x}]_0^2 \quad (\text{from part (a)}) \\ &= 3 [2e^6 - 0] = 6e^6 \end{aligned}$$

Question 27 (2 marks)

The function $f(x) = |x|$ is transformed and the equation of the new function is of the form $y = kf(x+b) + c$, where k , b and c are constants. The graph of the new function is shown.

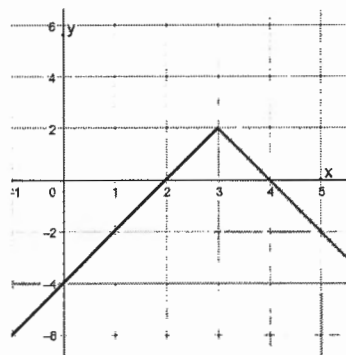

What are the values of k , b and c ?

$$\begin{array}{l} \text{Translated to the right by 3 units} \\ \text{Reflected through the } x\text{-axis} \\ \text{multiplied by 2} \\ \text{Translated up by 2 units} \end{array} \quad \left| \begin{array}{l} \therefore k = -2 \\ b = -3 \text{ and} \\ c = 2 \end{array} \right.$$

Question 28 (4 marks)

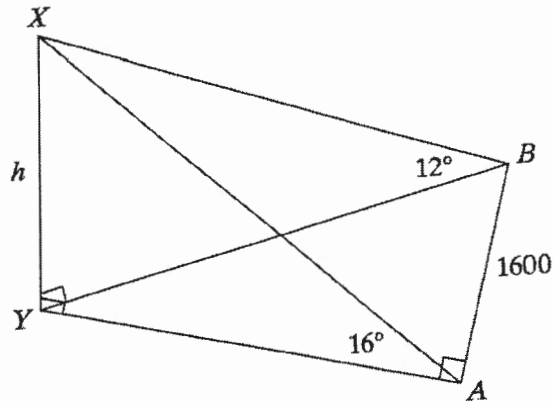

Dealan walks 1600 metres due north along a road from point A to point B .

The point is due east of a hill XY , where X is the top of the hill.

The point Y is directly below point X and is on the same horizontal plane as the road.

Let the height of the hill above point Y be h metres.

From point A , the angle of elevation to the top of the hill is 16° .

From point B , the angle of elevation to the top of the hill is 12° .

- (a) Show that $BY = h \cot 12^\circ$. [1 mark]

$$\frac{h}{BY} = \tan 12^\circ$$

$$\therefore \frac{BY}{h} = \cot 12^\circ$$

$$\therefore BY = h \cot 12^\circ$$

- (b) Hence, find the value of h . [3 marks]

Similarly, $AY = h \cot 16^\circ$
 Using Pythagoras' theorem for $\triangle BAY$

$$(h \cot 12^\circ)^2 = (h \cot 16^\circ)^2 + 1600^2$$

$$h^2 \cot^2 12^\circ = h^2 \cot^2 16^\circ + 1600^2$$

$$h^2 \cot^2 12^\circ - h^2 \cot^2 16^\circ = 1600^2$$

$$h^2 (\cot^2 12^\circ - \cot^2 16^\circ) = 1600^2$$

$$h^2 = \frac{1600^2}{\cot^2 12^\circ - \cot^2 16^\circ}$$

$$h = \frac{1600}{\sqrt{\cot^2 12^\circ - \cot^2 16^\circ}}$$

$h \approx 507$ (nearest whole number)

Question 29 (5 marks)

Let $y = f(x)$ be a function defined for $0 \leq x \leq 6$, with $f(0) = 0$.

The diagram shows the graph of the derivative of $f(x)$, $y = f'(x)$.

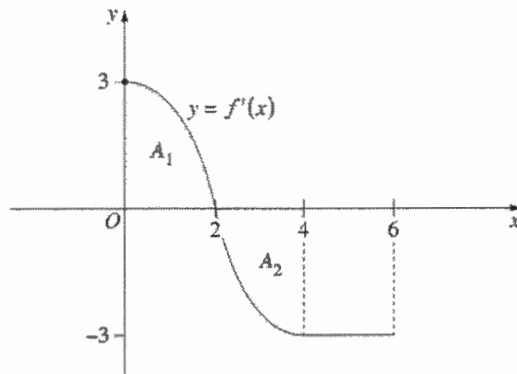

The shaded region A_1 has area 4 square units. The shaded region A_2 has area 4 square units.

(a) For what values of x is $f(x)$ increasing? [1 mark]

$f(x)$ is increasing when $f'(x) > 0$
from the graph $0 \leq x < 2$

(b) What is the maximum value of $f(x)$? [1 mark]

Maximum value of $f(x)$ occurs when $f'(x) = 0$; when
 $x = 2$ i.e. at $f(2)$
Now $\int_0^2 f'(x) dx = 4$
 $[f(x)]_0^2 = 4$
 $f(2) - f(0) = 4$
But $f(0) = 0 \rightarrow$ given
 $\therefore f(2) = 4$
 \therefore The maximum value of $f(x)$ is 4.

(c) Find the value of $f(6)$. [1 mark]

<p>Now $\int_2^4 f'(x) dx = -4$</p> $[f(x)]_2^4 = -4$ $f(4) - f(2) = -4$ <p>But $f(2) = 4$ from (b)</p> $\therefore f(4) - 4 = -4$ $f(4) = 0$	<p>From $x=4$ to $x=6$ the gradient is -3</p> <p>As $m = -3$ then</p> $-3 = \frac{f(6) - f(4)}{6 - 4}$ <p>$f(6) \neq$</p> $f(6) - 0 = -3 \times 2$ $\therefore f(6) = -6$
---	---

(d) Draw a graph of $y = f(x)$ for $0 \leq x \leq 6$. [2 marks]

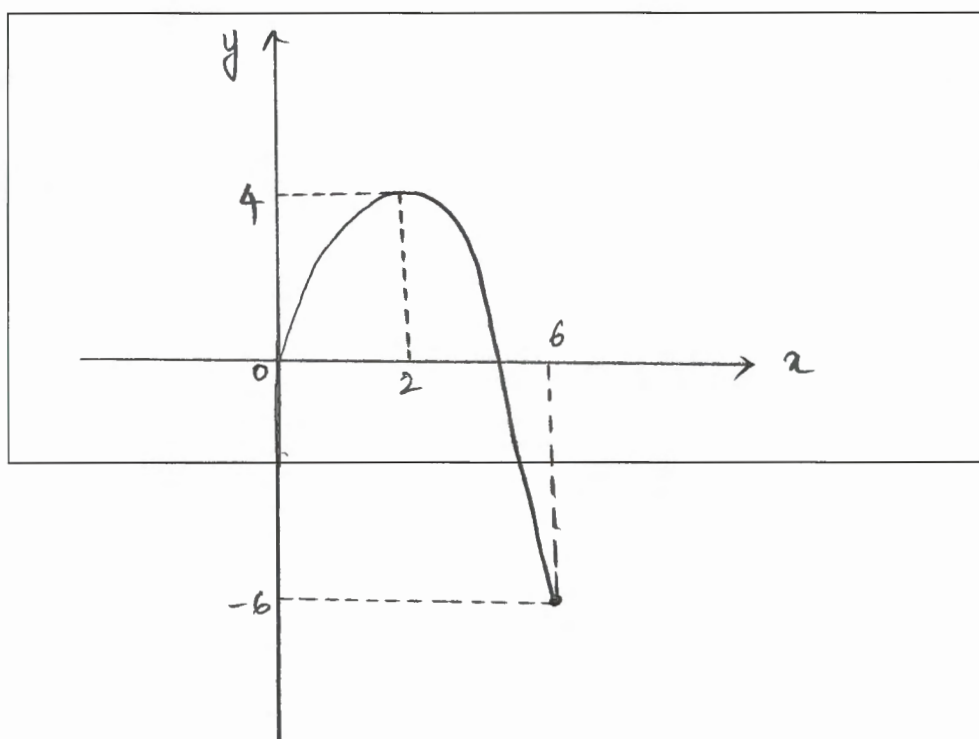

Question 30 (3 marks)

The length of a whale species is modelled using the equation

$$L = 5.2 - 4.6e^{-kt}$$

where L is in meters and t is the age in years and k is a positive constant.

- (a) What is the length of the whale at birth? [1 mark]

$$\text{when } t=0 ; l = 5.2 - 4.6 e^0 = l = 0.6 \text{ m}$$

- (b) If a three year old whale has a length of 4.45 metres, what is the value of k , correct to 2 decimal places? [1 mark]

$$\begin{array}{l} \text{At } t=3; L=4.45 \\ 4.45 = 5.2 - 4.6 e^{-k(3)} \\ 4.6 e^{-3k} = 0.75 \\ e^{-3k} = \frac{0.75}{4.6} \\ -3k \ln e = \ln\left(\frac{0.75}{4.6}\right) \\ k = \frac{-1}{3} \ln\left(\frac{0.75}{4.6}\right) \end{array} \quad \left| \quad k \approx 0.60 \text{ (correct to 2 decimal places)} \right.$$

- (c) Find the limiting length of the whale species. [1 mark]

$$\begin{array}{l} \text{Sub } t \rightarrow \infty \\ l = 5.2 - 4.6 e^{-k(t)} \\ l = 5.2 - \frac{4.6}{e^{kt}} \end{array} \quad \left| \quad \therefore \text{The limiting length is } 5.2 \text{ m.} \right.$$

As $t \rightarrow \infty$
 $\frac{4.6}{e^{kt}} \rightarrow 0$
 $\therefore 5.2 - \frac{4.6}{e^{kt}} \rightarrow 5.2$

Question 31 (2 marks)

Let $f(x) = x^3 - 3x^2 + kx + 8$, where k is a constant. Find the values of k for which $f(x)$ is an increasing function.

$$\begin{aligned} f(x) &= x^3 - 3x^2 + kx + 8 \\ f'(x) &= 3x^2 - 6x + k \end{aligned}$$

If $f(x)$ is an increasing function, then $f'(x) > 0$
Hence finding the values of k where $3x^2 - 6x + k$ is positive

i.e. $\Delta < 0$ and $a > 0$

$$\begin{aligned} &= (-6)^2 - 4(3)(k) < 0 \\ &= 36 - 12k < 0 \\ \therefore 12k &> 36 \\ k &> 3 \quad [\text{also, } a = 3 > 0] \end{aligned}$$

\therefore when $k > 3$, $f(x)$ is an increasing function

Question 32 (2 marks)

Find integers a and b such that $\frac{1}{\sqrt{5}-2} = a + b\sqrt{5}$.

$$\begin{aligned} \frac{1}{\sqrt{5}-2} &= a + b\sqrt{5} \\ \frac{1}{\sqrt{5}-2} \times \frac{\sqrt{5}+2}{\sqrt{5}+2} &= a + b\sqrt{5} \\ \frac{\sqrt{5}+2}{(\sqrt{5})^2 - (2)^2} &= a + b\sqrt{5} \\ \frac{\sqrt{5}+2}{5-4} &= a + b\sqrt{5} \end{aligned}$$

$\sqrt{5} + 2 = a + b\sqrt{5}$
Rearranging and
Comparing
 $a = 2$ and $b = 1$

Question 33 (4 marks)

A wire of length 28 m is to be cut into two pieces. One of the piece is to be made into a square and the other into a circle. Let r be the radius of the circle and x meters be the length of each side of the square. The combined perimeter is given as $2\pi r + 4x = 28$ and the combined area, A , is given by:

$$A = \pi \left(\frac{14 - 2x}{\pi} \right)^2 + x^2 \text{ (DO NOT prove this)}$$

What should be the lengths of each piece so that the combined area of the circle and the square is minimum?

$$A = \left(\frac{14 - 2x}{\pi} \right)^2 \pi + x^2$$

$$A = \frac{4}{\pi} (7 - x)^2 + x^2$$

$$A' = \frac{-8}{\pi} (7 - x) + 2x$$

$$A'' = \frac{8}{\pi} + 2$$

Sub $A' = 0$ to find the stationary points

$$\frac{-8}{\pi} (7 - x) + 2x = 0$$

$$\frac{-56}{\pi} + \frac{8x}{\pi} + 2x = 0$$

$$-56 + 8x + 2\pi x = 0$$

$$-28 + 4x + \pi x = 0$$

$$\therefore x = \frac{28}{\pi + 4}$$

when $x = \frac{28}{\pi + 4}$; $A'' = \frac{8}{\pi} + 2 > 0$ for all x
 \therefore minimum turning point.

The lengths of two portions are

$$4x = \frac{112}{\pi + 4} \text{ m} \quad \text{and} \quad 28 - 4x = 28 - \frac{112}{\pi + 4} = \frac{28\pi}{\pi + 4} \text{ m}$$

Question 34 (3 marks)

Initially a car is at rest. The car then starts from a point P at time $t = 0$ seconds and comes to a stop at point Q . The distance x , in metres covered by the car, in t seconds is given by $x = t^2 \left(2 - \frac{t}{3} \right)$. Find

(a) the time taken by it to reach Q . [2 marks]

$$x = t^2 \left(2 - \frac{t}{3} \right)$$
$$x = 2t^2 - \frac{t^3}{3}$$
$$\frac{dx}{dt} = 4t - t^2$$

This gives the velocity of the car at any time t
∴ the car stops at Q then $\frac{dx}{dt} = 0$
∴ $4t - t^2 = 0$; $t = 0$ and $t = 4$
∴ the car takes 4 seconds to reach Q .

(b) the distance between P and Q .

$$\text{At } t = 4$$
$$x = 2(4)^2 - \frac{(4)^3}{3}$$
$$x = 32 - \frac{64}{3}$$
$$x = \frac{32}{3} \text{ m}$$

Question 35 (5 marks)

The diagram shows the curve with equation $y = x^2 - 7x + 10$. The curve intersects the x -axis at points A and B . The point C on the curve has the same y -coordinate as the y -intercept of the curve.

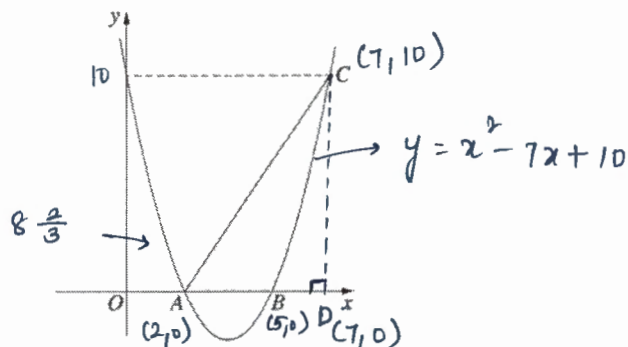

- (a) Find the x -coordinates of Points A and B . [1 mark]

$$\begin{aligned}x^2 - 7x + 10 &= 0 \\(x-2)(x-5) &= 0 \\x &= 2 \text{ and } 5\end{aligned}$$

\therefore the x -coordinates of points A and B are 2 and 5

- (b) Write down the coordinates of C . [1 mark]

y -intercept of $x^2 - 7x + 10$ is 10.

Sub $y=0$ in $y = x^2 - 7x + 10$

$$10 = x^2 - 7x + 10$$
$$0 = x^2 - 7x$$
$$x(x-7) = 0$$
$$x = 0 \text{ and } x = 7$$

$\therefore C(7, 10)$

(c) Evaluate [1 mark]

$$\int_0^2 (x^2 - 7x + 10) dx$$

$$\begin{aligned} \int_0^2 (x^2 - 7x + 10) dx &= \left[\frac{x^3}{3} - \frac{7x^2}{2} + 10x \right]_0^2 \\ &= \left[\frac{2^3}{3} - \frac{7(2)^2}{2} + 10(2) \right] - (0) \\ &= 8\frac{2}{3} \end{aligned}$$

(d) Hence, or otherwise, find the area of the shaded region. [2 marks]

$$\begin{aligned} \text{Area} &= \text{Area of } \triangle ACD = \int_0^2 (x^2 - 7x + 10) dx \\ &= \left(\frac{1}{2} \times 5 \times 10 \right) - 8\frac{2}{3} \quad (\text{from part (c)}) \end{aligned}$$

$$\text{Area} = 16\frac{1}{3} \text{ sq units}$$

Question 36 (5 marks)

- (a) A simple musical instrument has many strings. The difference between the lengths of adjacent strings is constant, so that the lengths of the strings are the terms of an arithmetics series. The shortest string is 30 cm long and the longest string is 48 cm. The sum of the lengths of all the strings is 1209 cm.

- i. Find the number of strings.[2 marks]

$a = 30; l = 48; S_n = 1209$ $S_n = \frac{n}{2}(a+l)$ $1209 = \frac{n}{2}(30+48)$ $2418 = 78n$	$n = \frac{2418}{78}$ $n = 31$ <p style="text-align: right;">↳ number of strings</p>
--	--

- ii. Find the difference in length between adjacent strings. [1 mark]

$T_n = a + (n-1)d$ $48 = 30 + (31-1)d$ $30d = 18$ $d = \frac{3}{5}$

- (b) There is a large sheet of paper which is 0.1 mm thick that is cut in half. Then one piece is placed on top of the other. This pile is again cut in half and one pile is placed on top of the other. This process is repeated 40 times. How high is the pile of the sheets? [2 marks]

<p>The thickness of the piles in the 40 successive cuts form a G.P</p> <p>0.2, 0.4, 0.8, ... ; where $a = 0.2$ (in mm) $r = 2$</p> $T_{40} = 0.2 \times 2^{39}$ $= 1.1 \times 10^{11}$ <p>∴ The final pile after 40 successive folds is 1.1×10^{11} mm or 110,000 km thick.</p>

Question 37 (4 marks)

(a) The function $f(x) = \sin x$ is transformed to $g(x) = 3\sin 2x$.

Describe in words how both the amplitude and period change in this transformation.

[2 marks]

Amplitude is multiplied by 3 and the period is halved

(b) Sketch $\frac{1}{x^2 - 49}$ clearly showing asymptotes and intercepts. [2 marks]

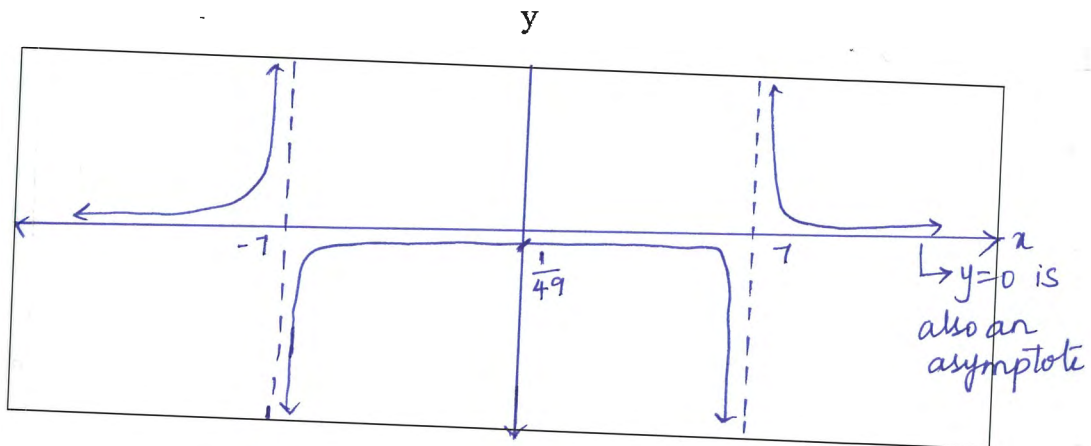

Question 38 (6 marks)

(a) Use trapezoidal rule with three function values to find an approximation to

$$\int_1^3 \ln x \, dx$$

[3 marks]

2	1	2	3
y	0	$\ln 2$	$\ln 3$

$$\int_1^3 \ln x \, dx \approx \frac{1}{2} (0 + \ln 3 + 2 \ln 2)$$
$$\approx \frac{1}{2} (\ln 3 + \ln 4)$$
$$\approx \frac{1}{2} \ln 12$$

\therefore The area is approximately $\frac{1}{2} \ln 12$ sq units

(b) State whether the approximation found in the previous part is greater than or lesser than exact value of $\int_1^3 \ln x \, dx$. Justify your answer by sketching the curve $y = \ln x$

[3 marks]

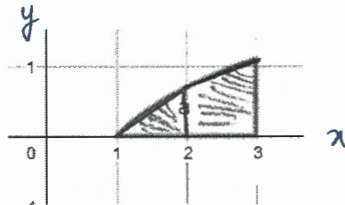

The shaded region on the diagram is the area found using the trapezoidal rule

\therefore It is less than the exact value of $\int_1^3 \ln x \, dx$.

End of exam