

HORNSBY GIRLS HIGH SCHOOL



Mathematics Extension 2

Year 12 Higher School Certificate
Trial Examination Term 3 2016

STUDENT NUMBER: _____

General Instructions

- Reading Time – 5 minutes
- Working Time – 3 hours
- Write using black or blue pen
Black pen is preferred
- Board-approved calculators and drawing templates may be used
- A reference sheet is provided separately
- In Questions 11 – 16, show relevant mathematical reasoning and/or calculations
- Marks may be deducted for untidy and poorly arranged work
- Do not use correction fluid or tape
- Do not remove this paper from the examination

Total marks – 100

Section I Pages 3 – 6

10 marks

Attempt Questions 1 – 10

Answer on the Objective Response Answer Sheet provided

Section II Pages 7 – 14

90 marks

Attempt Questions 11 – 16

Start each question in a new writing booklet

Write your student number on every writing booklet

<i>Question</i>	<i>1-10</i>	<i>11</i>	<i>12</i>	<i>13</i>	<i>14</i>	<i>15</i>	<i>16</i>	<i>Total</i>
<i>Total</i>	/10	/15	/15	/15	/15	/15	/15	/100

This assessment task constitutes 45% of the Higher School Certificate Course School Assessment

Section I

10 marks

Attempt Questions 1 – 10

Allow about 15 minutes for this section

Use the Objective Response answer sheet for Questions 1 – 10

- 1 The gradient of the tangent to the curve $x^3 - xy^2 + 8 = 0$ at the point $(1, 3)$ is:
- (A) 1
 - (B) -1
 - (C) $\frac{1}{2}$
 - (D) $\frac{1}{3}$
- 2 It is known that $x = 2 - 3i$ is a root of $x^4 - 6x^3 + 26x^2 - 46x + 65 = 0$. Another root of the equation is:
- (A) $x = 1 - 2i$
 - (B) $x = -1 - 2i$
 - (C) $x = -2 - i$
 - (D) $x = -2 + i$
- 3 The equation of the normal to the rectangular hyperbola $xy = c^2$ at the point $P\left(cp, \frac{c}{p}\right)$ is:
- (A) $p^2x - py + c - cp^4 = 0$
 - (B) $p^3x - py + c - cp^4 = 0$
 - (C) $x + p^2y - 2c = 0$
 - (D) $x + p^2y - 2cp = 0$

4 The graph of $y = \sin x$ for $-2\pi \leq x \leq 2\pi$ is shown below.

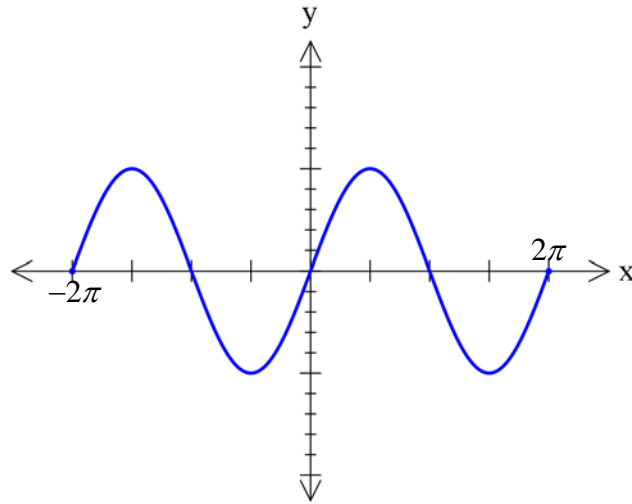

Which of the following is the graph of $y = 2 \log_e(\sin x)$ for $-2\pi \leq x \leq 2\pi$?

(A)

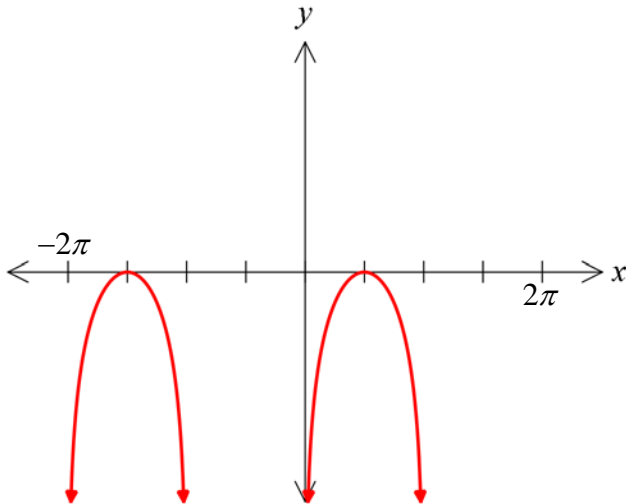

(B)

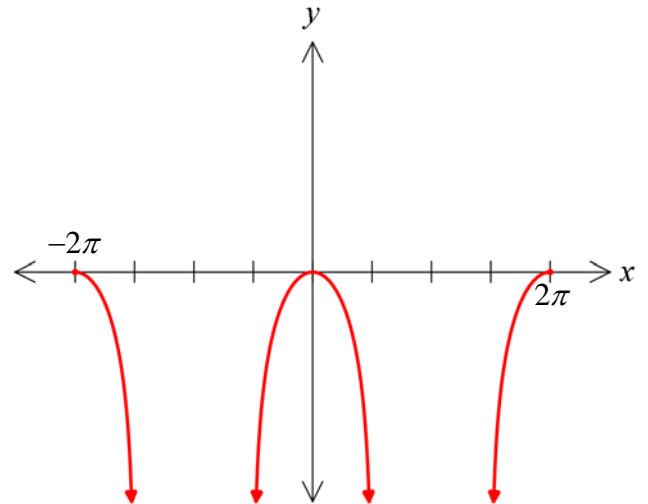

(C)

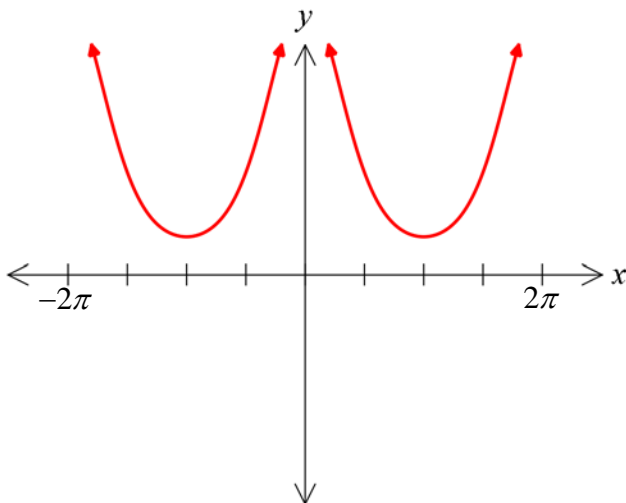

(D)

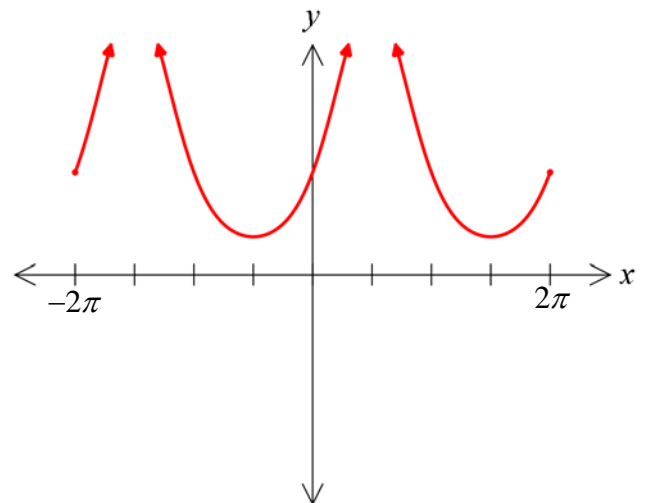

5 If $z = 2 + i$ and $w = 1 - i$, then $z\bar{w}$, in the form $x + iy$ is:

- (A) $3 - i$
- (B) $1 - 3i$
- (C) $1 + 3i$
- (D) $1 + i$

6 The reduction formula for $I_n = \int \tan^n x \, dx$ is:

- (A) $I_n = \frac{\tan^{n+1} x}{n+1} - I_{n-1}$
- (B) $I_n = \frac{\tan^{n-1} x}{n-1} - I_{n-1}$
- (C) $I_n = \frac{\tan^{n+1} x}{n+1} - I_{n-2}$
- (D) $I_n = \frac{\tan^{n-1} x}{n-1} - I_{n-2}$

7 The roots of the equation $2x^4 - 3x^3 + 4x + 9 = 0$ are α , β , δ and γ .
The value of $\alpha + \beta + \delta + \gamma - \alpha\beta\delta\gamma$ is:

- (A) 6
- (B) 3
- (C) -1
- (D) -3

8 Given that $P(x)$ is a polynomial with complex coefficients, it is known that three of the roots of the equation $P(x) = 0$ are $x = 1$, $x = 2 - i$ and $x = 3 + i$.

The minimum degree of $P(x)$ is:

- (A) 3
- (B) 4
- (C) 5
- (D) 6

- 9 The point P on the Argand Diagram below represents a complex number p , where $|p| = \frac{3}{2}$.

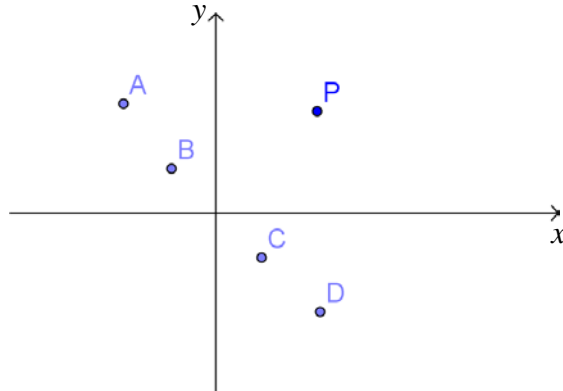

The number p^{-1} is best represented by the point

- (A) A
 - (B) B
 - (C) C
 - (D) D
- 10 The equation of the conic with eccentricity $\sqrt{2}$ and asymptotes $y = \pm x$ is:
- (A) $xy = 2$
 - (B) $x^2 - y^2 = 4$
 - (C) $xy = 1$
 - (D) $\frac{x^2}{4} - y^2 = 1$.

End of Section I

Section II

90 marks

Attempt Questions 11 – 16

Allow about 2 hours and 45 minutes for this section

Answer each question in a new writing booklet. Extra writing booklets are available.

In Questions 11 – 16, your responses should include relevant mathematical reasoning and/or calculations.

Question 11 (15 marks) Start a new writing booklet

- (a) (i) Express $1 - i\sqrt{3}$ in modulus-argument form. 1
- (ii) Express $(1 - i\sqrt{3})^6$ in the form $a + ib$. 2
- (b) (i) Find in modulus-argument form the five roots of $z^5 = -1$. 2
- (ii) Prove that when plotted on an Argand diagram these five roots form the vertices of a regular polygon which has an area of approximately 2.38 square units. 2
- (c) Find:
- (i) $\int \frac{\tan^{-1} x}{1+x^2} dx$ 1
- (ii) $\int \cos^2 x \sin^3 x dx$ 2
- (d) The ellipse E has Cartesian equation $\frac{x^2}{4} + \frac{y^2}{9} = 1$.
- (i) Calculate the eccentricity e of the ellipse. 1
- (ii) Find the coordinates of the foci S and S' and the equations of the directrices. 2
- (iii) Sketch the ellipse, showing the above features and intercepts. 2

Question 12 (15 marks) Start a new writing booklet

(a) Using the substitution $t = \tan \frac{\theta}{2}$, or otherwise, prove that $\int_0^{\frac{\pi}{3}} \frac{d\theta}{2+2\cos\theta} = \frac{\sqrt{3}}{6}$. **3**

(b) The polynomial equation $x^3 - 3x + 4 = 0$ has roots α , β and γ . Find the polynomial equation whose roots are:

(i) $\frac{1}{\alpha}$, $\frac{1}{\beta}$ and $\frac{1}{\gamma}$. **2**

(ii) $\alpha+3$, $\beta+3$ and $\gamma+3$ **2**

(c) The diagram shows the region bounded by $y^2 = 4(x-1)$ and the line $x=5$. **3**

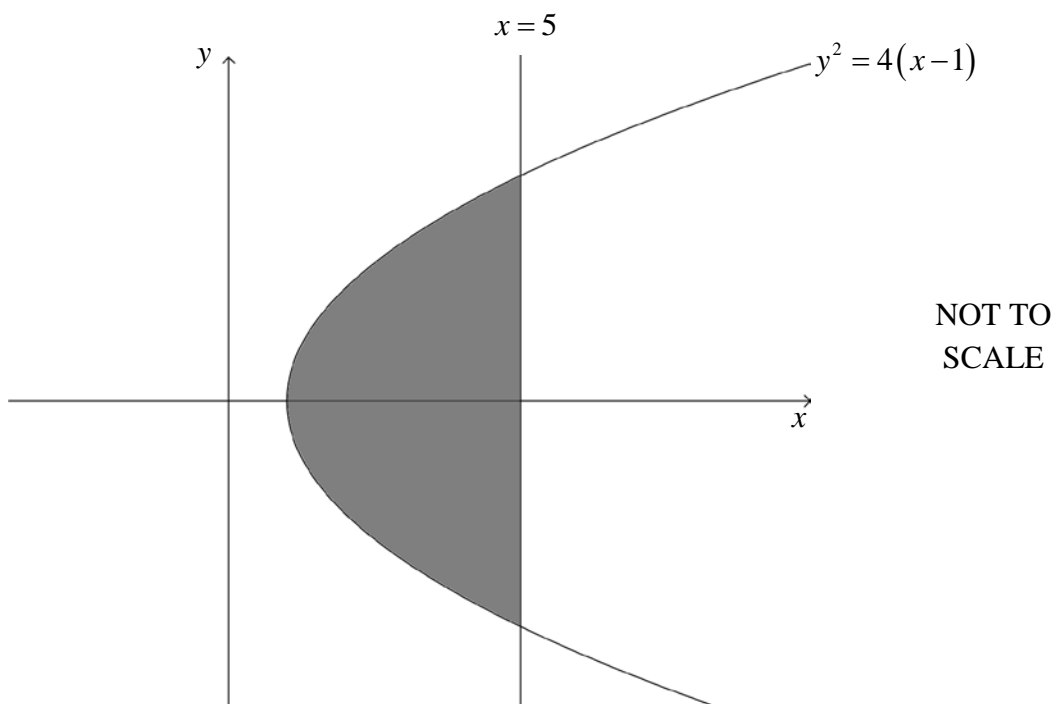

By using cylindrical shells, or otherwise, find the volume of the solid formed by rotating the given region about the y -axis.

(d) (i) If $I_n = \int_0^1 x^n (1-x)^{\frac{1}{2}} dx$, show that for $n > 0$, $I_n = \frac{2n}{2n+3} I_{n-1}$ where n is an integer. **3**

(ii) Hence, or otherwise, evaluate $\int_0^1 x^3 (1-x)^{\frac{1}{2}} dx$. **2**

Question 13 (15 marks) Start a new writing booklet

- (a) On the Argand diagram, shade the region specified by both the conditions $\operatorname{Re}(z) \leq 4$ and $|z - 4 + 5i| \leq 3$, showing the points of intersection of the boundaries. 2

- (b) Consider the region bounded by the lines $x = 1$, $y = 1$ and $y = -1$ and by the curve $x + y^2 = 0$. The region is rotated through 360° about the line $x = 4$ to form a solid. When the region is rotated, the line segment at the point $S(x, y)$ on $x + y^2 = 0$ sweeps out an annulus.

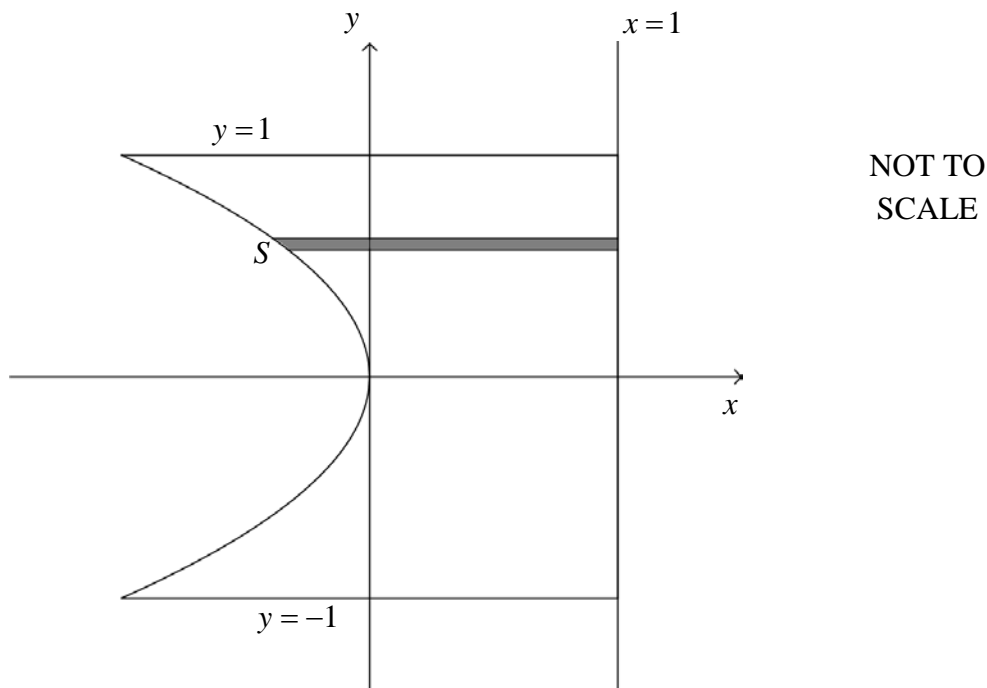

- (i) Show that the area of the annulus at height y is equal to $\pi(y^4 + 8y^2 + 7)$. 2
- (ii) Hence find the volume of the solid. 2
- (c) (i) If a, b, c are real and unequal show that $a^2 + b^2 > 2ab$. 1
- (ii) Hence deduce that $a^2 + b^2 + c^2 > ab + bc + ca$. 2

Question 13 continues on page 10

Question 13 (continued)

- (d) The diagram below shows a solid with circular base of radius 1. Parallel cross sections perpendicular to the base and the x -axis are equilateral triangles. Find the volume of the solid. 3

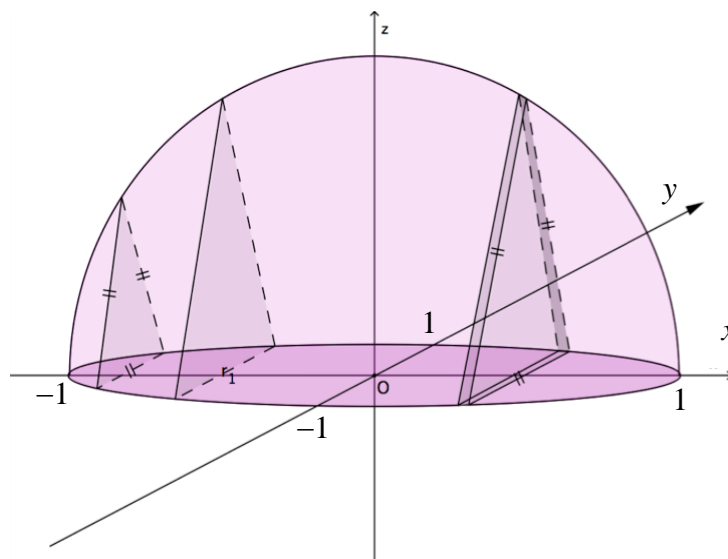

NOT TO SCALE

- (e) The points P , Q and R on the curve $y = \frac{2}{x}$ have x -coordinates 1, $\frac{3}{2}$ and 2 respectively. The points C and D are the feet of the perpendiculars drawn from P and R to the x -axis. The tangent to the curve at Q with equation $8x + 9y - 24 = 0$ cuts PC and RD at M and N respectively.

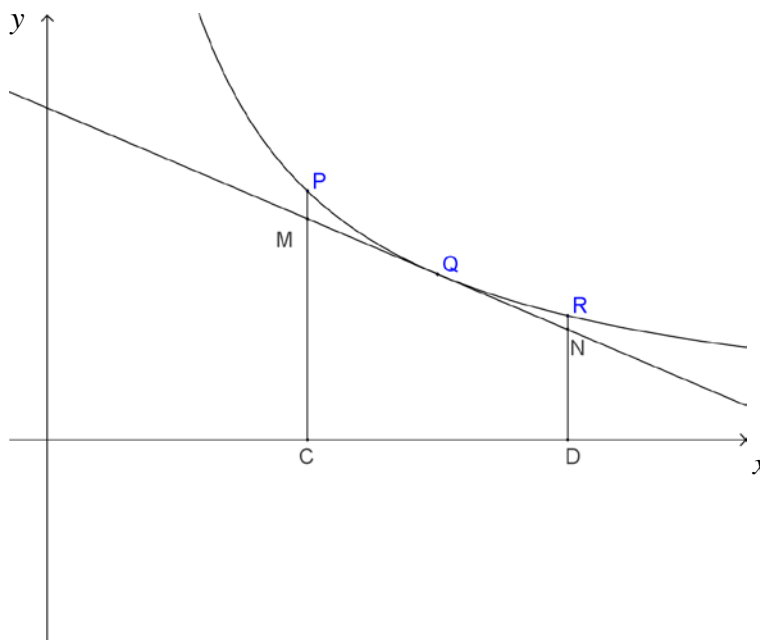

NOT TO SCALE

- (i) Find the coordinates of M and N . 1
- (ii) Using areas and integration, show that $\frac{2}{3} < \ln 2 < \frac{3}{4}$. 2

End of Question 13

Question 14 (15 marks) Start a new writing booklet

(a) (i) If $\frac{16x}{x^4-16} \equiv \frac{A}{x-2} + \frac{B}{x+2} + \frac{Cx}{x^2+4}$, find the values of A , B and C . 2

(ii) Hence, show that $\int_4^6 \frac{16x}{x^4-16} dx = \log_e \left(\frac{4}{3} \right)$. 2

(b) Consider the function $f(x) = \frac{(x-2)(x+1)}{x-4}$ for $x \neq 4$.

(i) Show that $f(x) = x+3 + \frac{10}{x-4}$. 1

(ii) Explain why the graph of $y = f(x)$ approaches $y = x+3$ as x approaches ∞ . 1

(iii) Find the values of x for which $f(x)$ is positive. 2

(iv) Show that the graph of $y = f(x)$ has two stationary points.
You do not need to find the y values of the stationary points. 1

(v) Sketch the curve $y = f(x)$, labelling all asymptotes and x intercepts. 2

(c) The graphs of $y = f(x)$, $y = 1$ and $y = -1$ are shown below.

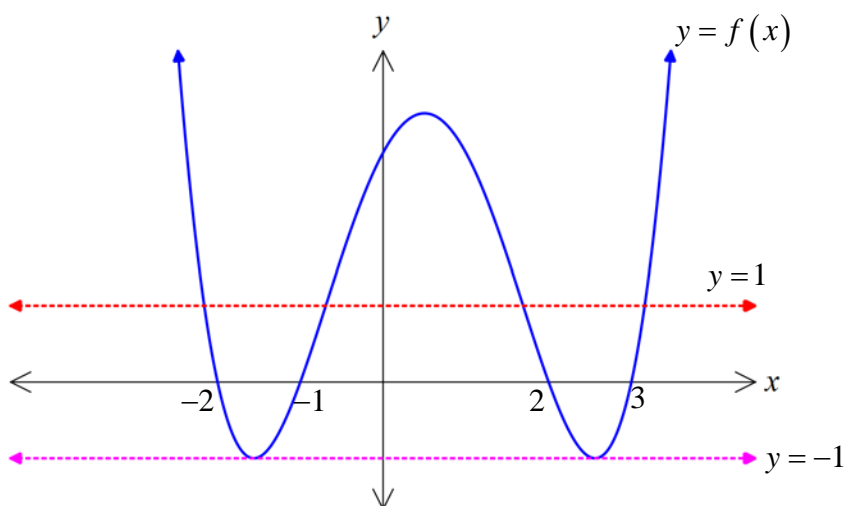

Sketch each of the following on a separate number plane:

(i) $y = |f(x)|$ 1

(ii) $y^2 = f(x)$ 2

(iii) $y = f(|x|)$ 1

Question 15 (15 marks) Start a new writing booklet

(a) (i) Use the substitution $x = a - y$ to show that $\int_0^a f(x) dx = \int_0^a f(a-x) dx$. 1

(ii) Hence, or otherwise, evaluate $\int_0^1 x(1-x)^{20} dx$. 2

(b) In the diagram below, AB is a common tangent of the two circles which intersect at P and Q .

XPB and APY are straight lines. XA produced and YB produced meet at T .

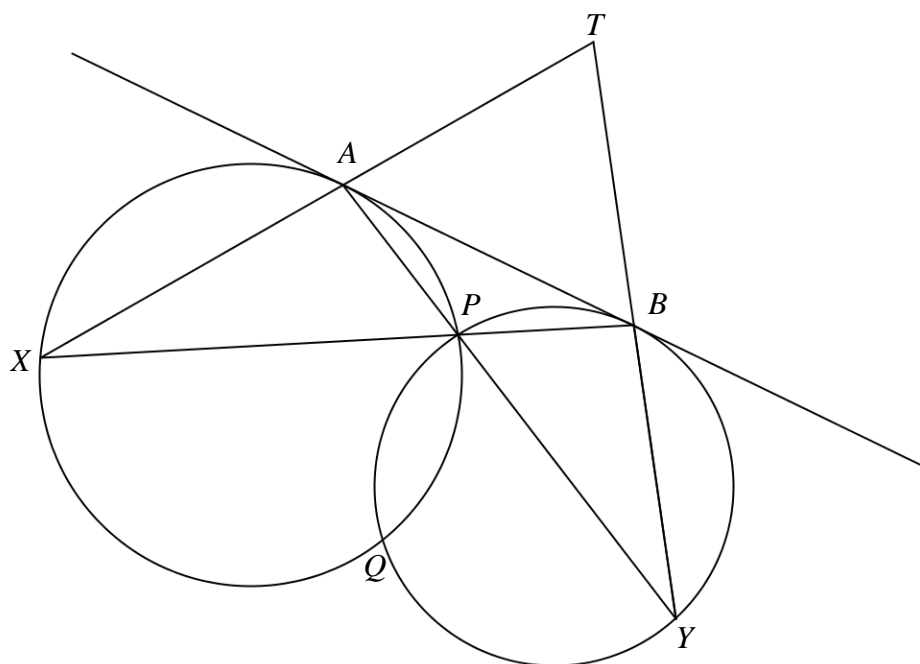

NOT TO
SCALE

Copy or trace the diagram into your writing booklet

(i) Prove that $AT = TB$. 1

(ii) If $ATBP$ is a cyclic quadrilateral, find the size of $\angle TAB$. 2

(c) (i) Use the substitution $u = -x$ to show that $\int_{-2}^2 \frac{x^2}{e^x + 1} dx = \int_{-2}^2 \frac{x^2 e^x}{e^x + 1} dx$. 1

(ii) Hence, or otherwise, evaluate $\int_{-2}^2 \frac{x^2}{e^x + 1} dx$. 2

Question 15 continues on page 13

Question 15 (continued)

- (d) The line $y = x$ meets a directrix of the ellipse $\frac{x^2}{a^2} + \frac{y^2}{b^2} = 1$ where $a > b$ at the point T in the first quadrant. Tangents from T meet the ellipse at $P(x_1, y_1)$ and $Q(x_2, y_2)$. The eccentricity of the ellipse is e .

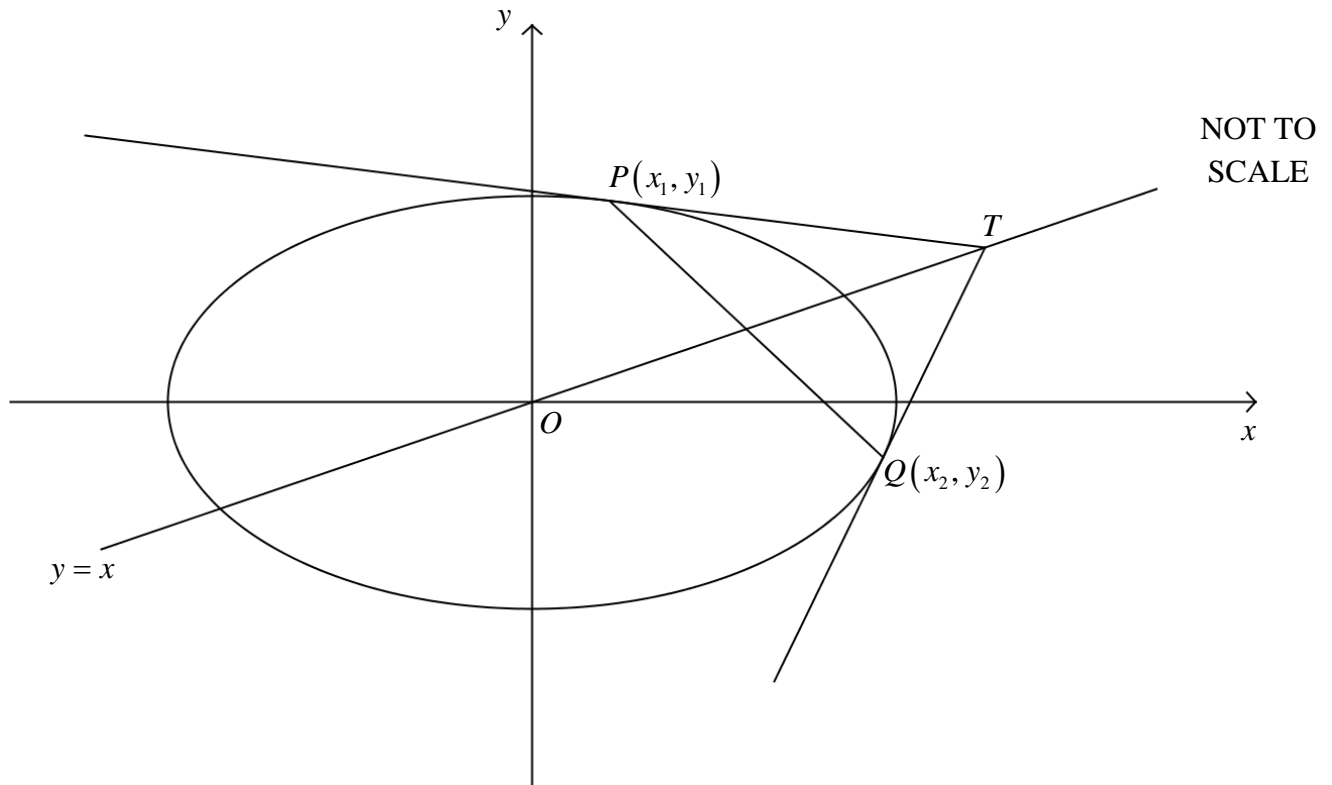

- (i) Given that the chord of contact of the tangents from the point (x_0, y_0) to the ellipse $\frac{x^2}{a^2} + \frac{y^2}{b^2} = 1$ has equation $\frac{xx_0}{a^2} + \frac{yy_0}{b^2} = 1$, deduce that the equation of PQ is $\frac{x}{ae} + \frac{y}{ae(1-e^2)} = 1$ and verify that PQ is a focal chord of the ellipse. 2
- (ii) Show that x_1 and x_2 are roots of the equation $(2-e^2)x^2 - 2ae(1-e^2)x + a^2(e^2 - e^4 - 1) = 0$. 2
- (iii) Show that the midpoint M of the chord PQ lies on the line $y = x$. 2

End of Question 15

Question 16 (15 marks) Start a new writing booklet

- (a) z is a complex number which satisfies $|z-1|=1$. Let $\arg(z)=\theta$, where θ is acute.
- (i) Show graphically that $\arg(z-1)=2\theta$. 1
- (ii) Hence, or otherwise, find $\arg(z^2-3z+2)$ in terms of θ . 2
- (b) If $a > 0$, $b > 0$ and $c > 0$, and $a + \frac{1}{a} \geq 2$, show that:
- (i) $(a+b)\left(\frac{1}{a} + \frac{1}{b}\right) \geq 4$ 1
- (ii) $(a+b)(b+c)(c+a) \geq 8abc$ 2
- (c) A particle of mass m is projected vertically upwards under gravity. The air resistance to the motion is $\frac{1}{100}mgv^2$ where v is the speed of the particle.
- (i) Show that during the upward motion of the particle, if x is the upward vertical displacement of the particle from its projection point at time t , then 1
- $$\ddot{x} = -\frac{1}{100}g(100+v^2).$$
- (ii) If the speed of projection is u , show that the greatest height (above the projection point) 2
- reached by the particle is $\frac{50}{g} \log_e \left(\frac{100+u^2}{100} \right)$.
- (iii) Show that during the downward motion of the particle, if x is the downward vertical displacement of the particle from its highest position at time t after it begins the 2
- downward motion, then $\ddot{x} = \frac{1}{100}g(100-v^2)$.
- (iv) Show that the speed of the particle on return to its point of projection is $\frac{10u}{\sqrt{100+u^2}}$. 2
- (v) Find the terminal velocity V of the particle for the downward motion. 1
- (vi) If the initial speed of projection of the particle is V , show that the speed on return to the 1
- point of projection is $\frac{1}{\sqrt{2}}V$.

End of Examination

Mathematics Extension 2 Trial 2016

Multiple Choice

Question 1

$$x^3 - xy^2 + 8 = 0$$

Implicitly differentiating:

$$3x^2 - y^2 - 2xy \frac{dy}{dx} = 0$$

$$2xy \frac{dy}{dx} = 3x^2 - y^2$$

$$\frac{dy}{dx} = \frac{3x^2 - y^2}{2xy}$$

At (1,3)

$$\frac{dy}{dx} = \frac{3-9}{2 \times 1 \times 3}$$

$$= \frac{-6}{6}$$

$$= -1$$

(B)

Question 2:

$$\sum \text{roots one at a time} = 6$$

$$2 + 2 + a + a = 6$$

$$a = 1$$

$$(2 - 3i) + (2 + 3i) + (a + ib) + (a - ib) = 6$$

$$4 + 2a = 6$$

$$2a = 2$$

$$a = 1$$

$$\therefore \textcircled{A}$$

Question 3:

$$xy = c^2$$

$$y = c^2 x^{-1}$$

$$\frac{dy}{dx} = \frac{-c^2}{x^2}$$

At $x = cp$

$$\frac{dy}{dx} = \frac{-c^2}{c^2 p^2}$$

$$= \frac{-1}{p^2}$$

Gradient of normal is p^2

$$y - \frac{c}{p} = p^2(x - cp)$$

$$py - c = p^3x - cp^4$$

$$p^3x - py + c - cp^4 = 0$$

(B)

Question 4:

(A)

Question 5

$$z\bar{w} = (2+i)(1+i)$$

$$= 2 + 2i + i - i^2$$

$$= 1 + 3i$$

(C)

Question 6

$$I_n = \int \tan^n x dx$$

$$= \int \tan^2 x \tan^{n-2} x dx$$

$$= \int \sec^2 x \tan^{n-2} x dx - \int \tan^{n-2} x dx$$

$$= \frac{\tan^{n-1} x}{n-1} - I_{n-2}$$

(D)

Question 7

$$\alpha + \beta + \gamma + \delta = \frac{3}{2}$$

$$\alpha\beta\gamma\delta = \frac{9}{2}$$

$$\frac{3}{2} - \frac{9}{2} = -3$$

(D)

Question 8:

Three known roots, therefore degree 3 as polynomial may have unreal coefficients, so not essential they occur in conjugate pairs.

(A)

Question 9:

$$|p| = \frac{3}{2}$$

$$\left| \frac{1}{p} \right| = \frac{2}{3}$$

$$\arg(p) > 0$$

$$\arg(p^{-1}) < 0$$

Therefore (C)

Question 10:

Due to asymptotes, know it is not hyperbola in form $xy = c^2$

$$e^2 = 1 + \frac{b^2}{a^2}$$

$$2 = 1 + \frac{b^2}{a^2}$$

$$\therefore b = a$$

(B)

Question 11

(a)

Let $z = 1 - i\sqrt{3}$

(i)

$$\begin{aligned} |z| &= \sqrt{1^2 + (-\sqrt{3})^2} & \arg(z) &= -\tan^{-1} \frac{\sqrt{3}}{1} \\ &= \sqrt{4} & & \\ &= 2 & &= -\frac{\pi}{3} \end{aligned}$$

(ii)

$$\begin{aligned} (1 - i\sqrt{3})^6 &= 2^6 \left(\cos \frac{6\pi}{3} + i \sin \frac{6\pi}{3} \right) \\ &= 2^6 (\cos 2\pi + i \sin 2\pi) \\ &= 2^6 \\ &= 64 \end{aligned}$$

(b)

(i)

$$z^5 = -1$$

$$= \cos \pi + i \sin \pi$$

$$z = \cos \left(\frac{2k\pi + \pi}{5} \right) + i \sin \left(\frac{2k\pi + \pi}{5} \right)$$

Let $k = 0$:

$$z_0 = \cos \frac{\pi}{5} + i \sin \frac{\pi}{5}$$

Let $k = 1$:

$$z_1 = \cos \frac{3\pi}{5} + i \sin \frac{3\pi}{5}$$

Let $k = 2$:

$$\begin{aligned} z_2 &= \cos \frac{5\pi}{5} + i \sin \frac{5\pi}{5} \\ &= \cos \pi + i \sin \pi \end{aligned}$$

Let $k = 3$:

$$\begin{aligned} z_3 &= \cos \frac{7\pi}{5} + i \sin \frac{7\pi}{5} \\ &= \cos \left(-\frac{3\pi}{5} \right) + i \sin \left(-\frac{3\pi}{5} \right) \end{aligned}$$

Let $k = 4$:

$$\begin{aligned} z_4 &= \cos \frac{9\pi}{5} + i \sin \frac{9\pi}{5} \\ &= \cos \left(-\frac{\pi}{5} \right) + i \sin \left(-\frac{\pi}{5} \right) \end{aligned}$$

(ii)

$$\begin{aligned} \text{Area} &= 5 \times \frac{1}{2} \times a \times b \times \sin \theta \\ &= 5 \times 1 \times 1 \times \sin \frac{2\pi}{5} \\ &= 2.3776... \\ &= 2.38 \text{ units}^2 \quad (2dp) \end{aligned}$$

(c)

(i)

$$\begin{aligned} \int \frac{\tan^{-1} x}{1+x^2} dx &= \int \frac{1}{1+x^2} \tan^{-1} x dx \\ &= \frac{(\tan^{-1} x)^2}{2} + C \end{aligned}$$

(ii)

$$\begin{aligned} \int \cos^2 x \sin^3 x dx &= \int \cos^2 x (1 - \cos^2 x) \sin x dx \\ &= \int \cos^2 x \sin x - \cos^4 x \sin x dx \\ &= \frac{-\cos^3 x}{3} + \frac{\cos^5 x}{5} + C \end{aligned}$$

(d)

$$\frac{x^2}{4} + \frac{y^2}{9} = 1$$

(i)

$$a = 2, b = 3$$

$$4 = 9(1 - e^2)$$

$$\frac{4}{9} = 1 - e^2$$

$$e^2 = \frac{5}{9}$$

$$e = \frac{\sqrt{5}}{3} \quad (e > 0)$$

(ii)

$$S = (0, be)$$

$$= \left(0, 3 \times \frac{\sqrt{5}}{3} \right)$$

$$= (0, \sqrt{5})$$

$$S' = (0, -\sqrt{5})$$

Directrices:

$$y = \pm \frac{b}{e}$$
$$= \pm 3 \times \frac{3}{\sqrt{5}}$$
$$= \pm \frac{9}{\sqrt{5}}$$

(iii)

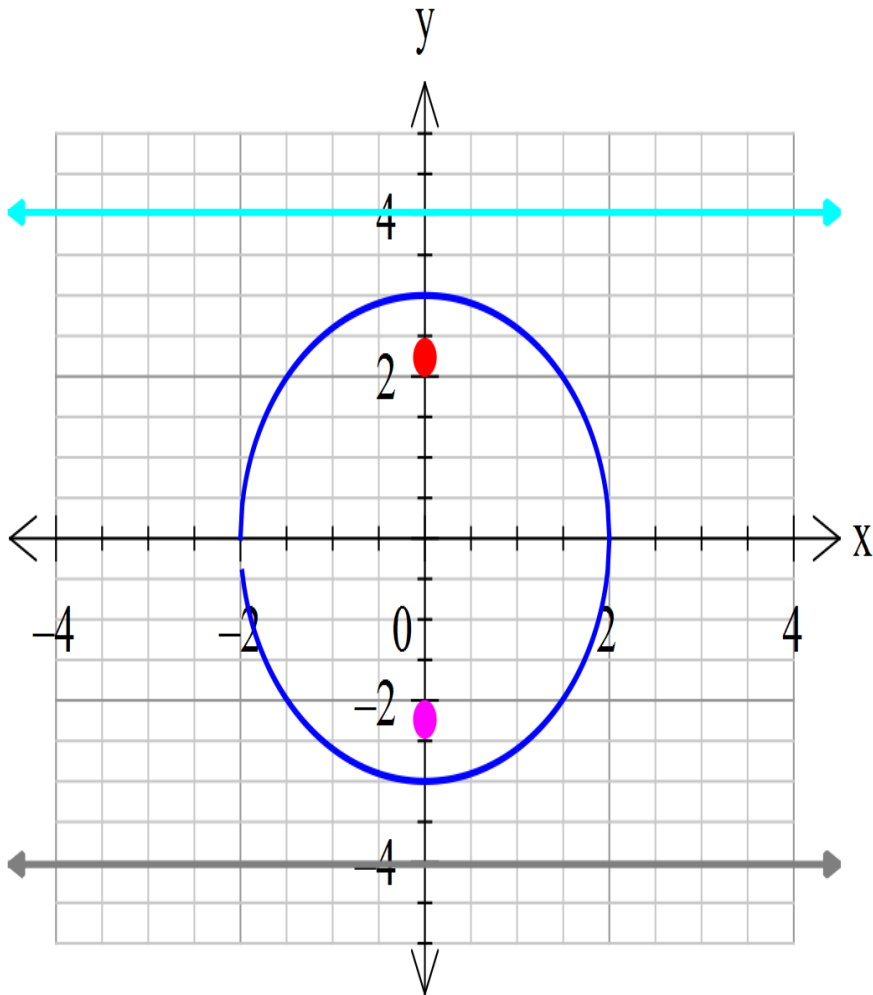

Question 12

(a)

$$\text{Let } I = \int_0^{\frac{\pi}{3}} \frac{d\theta}{2+2\cos\theta}$$

$$\text{Let } t = \tan \frac{\theta}{2}$$

$$\theta = 2 \tan^{-1} t$$

$$\frac{d\theta}{dt} = \frac{2}{1+t^2}$$

$$d\theta = \frac{2dt}{1+t^2}$$

When $\theta = 0, t = 0$ and when $\theta = \frac{\pi}{3}, t = \frac{1}{\sqrt{3}}$

$$\therefore I = \int_0^{\frac{1}{\sqrt{3}}} \left(\frac{2dt}{1+t^2} \right) \div \left(2+2\left(\frac{1-t^2}{1+t^2} \right) \right)$$

$$= \int_0^{\frac{1}{\sqrt{3}}} \left(\frac{2dt}{1+t^2} \right) \div \left(\frac{2+2t^2+2+2t^2}{1+t^2} \right)$$

$$= \frac{1}{2} \int_0^{\frac{1}{\sqrt{3}}} dt$$

$$= \frac{1}{2} [t]_0^{\frac{1}{\sqrt{3}}}$$

$$= \frac{1}{2} \times \frac{1}{\sqrt{3}}$$

$$= \frac{1}{2} \times \frac{\sqrt{3}}{3}$$

$$= \frac{\sqrt{3}}{6}$$

(b)

$$x^3 - 3x + 4 = 0$$

(i)

$$\left(\frac{1}{x} \right)^3 - 3 \left(\frac{1}{x} \right) + 4 = 0$$

$$\frac{1}{x^3} - \frac{3}{x} + 4 = 0$$

$$1 - 3x^2 + 4x^3 = 0$$

$$4x^3 - 3x^2 + 1 = 0$$

(ii)

$$(x-3)^3 - 3(x-3) + 4 = 0$$

$$x^3 - 3x^2 \times 3 + 3x \times 3^2 - 27 - 3x + 9 + 4 = 0$$

$$x^3 - 9x^2 + 27x - 27 - 3x + 13 = 0$$

$$x^3 - 9x^2 + 24x - 14 = 0$$

(c)

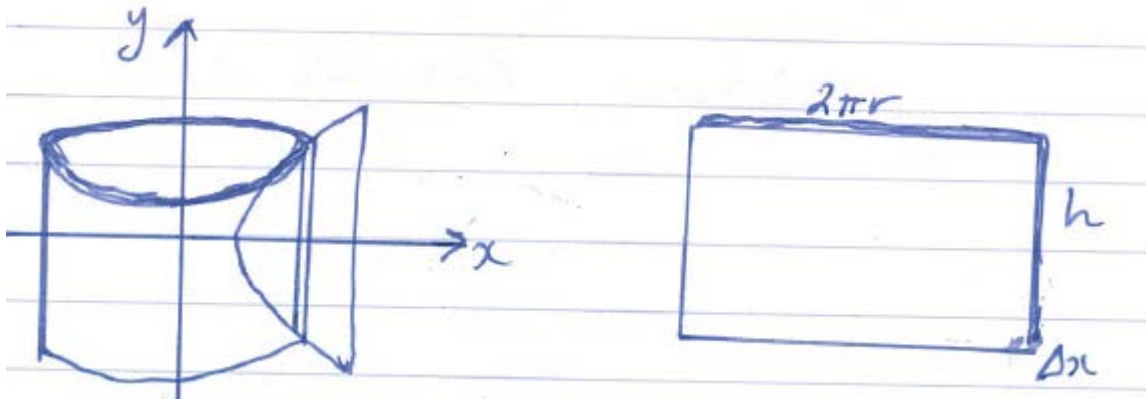

$$h = 2y$$

$$r = x$$

$$\Delta V = 2\pi rh$$

$$= 2\pi x \times 2y \Delta x$$

$$= 4\pi x \times 2\sqrt{x-1} \Delta x$$

$$= 8\pi x \sqrt{x-1} \Delta x$$

$$V \approx \sum_{x=1}^5 8\pi x \sqrt{x-1} \Delta x$$

$$V = \lim_{\Delta x \rightarrow 0} \sum_{x=1}^5 8\pi x \sqrt{x-1} \Delta x$$

$$= 8\pi \int_1^5 x \sqrt{1-x} dx$$

$$= 8\pi \int_0^4 (u+1) \sqrt{u} du$$

$$= 8\pi \int_0^4 \left(u^{\frac{3}{2}} + u^{\frac{1}{2}} \right) du$$

$$= 8\pi \left[\frac{2}{5} u^{\frac{5}{2}} + \frac{2}{3} u^{\frac{3}{2}} \right]_0^4$$

$$= 8\pi \left(\frac{2}{5} \times 4^{\frac{5}{2}} + \frac{2}{3} \times 4^{\frac{3}{2}} \right)$$

$$= 8\pi \times \frac{272}{15}$$

$$= \frac{2176}{15} \pi \text{ units}^3$$

(d)

(i)

$$\text{Let } I_n = \int_0^1 x^n (1-x)^{\frac{1}{2}} dx$$

$$u = x^n$$

$$v' = (1-x)^{\frac{1}{2}}$$

$$u = nx^{n-1}$$

$$v = \frac{-2}{3} (1-x)^{\frac{3}{2}}$$

$$\begin{aligned}
I_n &= \left[\frac{-2}{3} x^n (1-x)^{\frac{3}{2}} \right]_0^1 + \frac{2n}{3} \int_0^1 x^{n-1} (1-x)(1-x)^{\frac{1}{2}} dx \\
&= 0 + \frac{2n}{3} \int_0^1 x^{n-1} (1-x)^{\frac{1}{2}} dx - \frac{2n}{3} \int_0^1 x^n (1-x)^{\frac{1}{2}} dx \\
&= \frac{2n}{3} I_{n-1} - \frac{2n}{3} I_n
\end{aligned}$$

$$I_n \left(1 + \frac{2n}{3} \right) = \frac{2n}{3} I_{n-1}$$

$$I_n \left(\frac{3+2n}{3} \right) = \frac{2n}{3} I_{n-1}$$

$$I_n = \frac{2n}{3+2n} I_{n-1}$$

(ii)

$$I_3 = \frac{6}{9} I_2$$

$$= \frac{6}{9} \times \frac{4}{7} I_1$$

$$= \frac{6}{9} \times \frac{4}{7} \times \frac{2}{5} I_0$$

$$= \frac{16}{105} \int_0^1 (1-x)^{\frac{1}{2}} dx$$

$$= \frac{16}{105} \left[\frac{-2}{3} (1-x)^{\frac{3}{2}} \right]_0^1 = \frac{16}{105} \left(\frac{2}{3} \right)$$

$$= \frac{32}{315}$$

Question 13

(a)

$$\operatorname{Re}(z) \leq 4$$

$$x \leq 4$$

$$|z - (4 - 5i)| \leq 3$$

Circle with centre $(4, -5)$ and radius is 3.

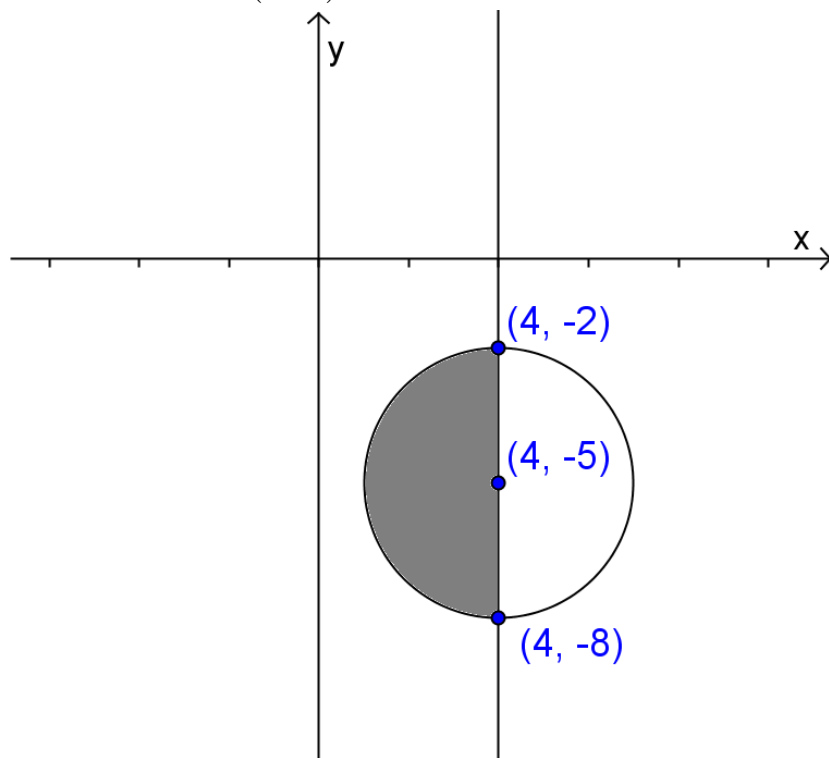

(b)

(i)

$$A = \pi(R^2 - r^2)$$

$$= \pi[(4-x)^2 - 3^2]$$

$$= \pi[(4+y^2) - 9]$$

$$= \pi(16 + 8y^2 + y^4 - 9)$$

$$= \pi(y^4 + 8y^2 + 7)$$

(ii)

$$V \approx \sum_{y=-1}^1 \pi(y^4 + 8y^2 + 7) \Delta y$$

$$\begin{aligned} V &= \lim_{\Delta y \rightarrow 0} \sum_{y=-1}^1 \pi(y^4 + 8y^2 + 7) \Delta y \\ &= \pi \int_{-1}^1 (y^4 + 8y^2 + 7) dy \\ &= 2\pi \int_0^1 (y^4 + 8y^2 + 7) dy \\ &= 2\pi \left[\frac{y^5}{5} + \frac{8y^3}{3} + 7y \right]_0^1 \\ &= 2\pi \left[\frac{1}{5} + \frac{8}{3} + 7 \right] \\ &= \frac{296\pi}{15} \end{aligned}$$

(c)

(i)

$$(a-b)^2 > 0 \text{ since } a-b \neq 0$$

$$a^2 - 2ab + b^2 > 0$$

$$a^2 + b^2 > 2ab$$

(ii)

$$a^2 + b^2 > 2ab$$

$$b^2 + c^2 > 2bc$$

$$c^2 + a^2 > 2ac$$

$$\therefore a^2 + b^2 + b^2 + c^2 + c^2 + a^2 > 2ab + 2bc + 2ac$$

$$2a^2 + 2b^2 + 2c^2 > 2(ab + bc + ac)$$

$$2(a^2 + b^2 + c^2) > 2(ab + bc + ac)$$

$$a^2 + b^2 + c^2 > ab + bc + ac$$

(ii)

$$\Delta V = \frac{1}{2} ab \sin C$$

$$= \frac{1}{2} \times 2y \times 2y \times \sin 60^\circ \Delta x$$

$$= 2y^2 \times \frac{\sqrt{3}}{2} \Delta x$$

$$= \sqrt{3} y^2 \Delta x$$

$$= \sqrt{3} (1-x^2) \Delta x$$

$$V \approx \sum_{-1}^1 \sqrt{3}(1-x^2)\Delta x$$

$$V = \lim_{\Delta x \rightarrow 0} \sum_{-1}^1 \sqrt{3}(1-x^2)\Delta x$$

$$= \int_{-1}^1 \sqrt{3}(1-x^2)dx$$

$$= 2 \int_0^1 \sqrt{3}(1-x^2)dx$$

$$= 2\sqrt{3} \left[x - \frac{x^3}{3} \right]_0^1$$

$$= 2\sqrt{3} \left(1 - \frac{1}{3} \right)$$

$$= \frac{4\sqrt{3}}{3} \text{ cubic units}$$

(e)

(i)

$$8x + 9y - 24 = 0$$

Let $x = 1$

$$8 + 9y - 24 = 0$$

$$9y = 16$$

$$y = \frac{16}{9}$$

$$M \left(1, \frac{16}{9} \right)$$

Let $x = 2$

$$16 + 9y - 24 = 0$$

$$9y = 8$$

$$y = \frac{8}{9}$$

$$N \left(2, \frac{8}{9} \right)$$

(ii)

$$A_{MNCD} < \int_1^2 \frac{2}{x} dx < A_{PRDC}$$

$$\frac{1}{2} \left(\frac{16}{9} + \frac{8}{9} \right) < 2[\ln x]_1^2 < \frac{1}{2}(2+1)$$

$$\frac{4}{3} < 2\ln 2 - 2\ln 1 < \frac{3}{2}$$

$$\frac{2}{3} < \ln 2 < \frac{3}{4}$$

Question 14

(a)

(i)

$$\frac{16x}{x^4 - 16} \equiv \frac{A}{x-2} + \frac{B}{x+2} + \frac{Cx}{x^2 + 4}$$

$$16x = A(x+2)(x^2 + 4) + B(x-2)(x^2 + 4) + Cx(x^2 - 4)$$

Let $x = 2$

$$32 = A \times 4 \times 8$$

$$A = 1$$

Let $x = -1$

$$-16 = B(-4)(8)$$

$$B = 1$$

Let $x = 1$

$$16 = (3)(5) + (-1)(5) + C(-3)$$

$$16 = 15 - 5 - 3C$$

$$6 = -3C$$

$$C = -2$$

(ii)

$$\begin{aligned} \int_4^6 \frac{16x}{x^4 - 16} dx &= \int_4^6 \left(\frac{1}{x-2} + \frac{1}{x+2} - \frac{2x}{x^2 + 4} \right) dx \\ &= \left[\ln |x-2| + \ln |x+2| - \ln |x^2 + 4| \right]_4^6 \\ &= \left[\ln \frac{x^2 - 4}{x^2 + 4} \right]_4^6 \\ &= \frac{\ln 32}{40} - \ln \frac{12}{20} \\ &= \ln \frac{4}{5} + \ln \frac{5}{3} \\ &= \ln \left(\frac{4}{5} \times \frac{5}{3} \right) \\ &= \ln \frac{4}{3} \end{aligned}$$

(b)

$$f(x) = \frac{(x-2)(x+1)}{x-3}$$

(i)

$$\begin{aligned}
 x+3+\frac{10}{x-4} &= \frac{(x+3)(x-4)+10}{x-4} \\
 &= \frac{x^2+3x-4x-12+10}{x-4} \\
 &= \frac{x^2-x-2}{x-4} \\
 &= \frac{(x-2)(x+1)}{x-4}
 \end{aligned}$$

(ii)

$$\text{As } x \rightarrow \infty, \frac{10}{x-4} \rightarrow 0$$

$$\therefore y \rightarrow x+3$$

(iii) Let $f(x) > 0$

$$\frac{(x-2)(x+1)}{x-4} > 0$$

$$(x-4)(x-2)(x+1) > 0$$

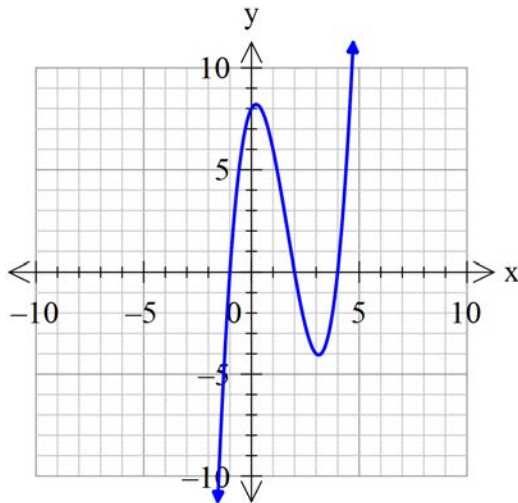

$$\therefore f(x) > 0 \text{ for } x > 4, -1 < x < 2$$

(iv)

$$f(x) = x+3+10(x-4)^{-1}$$

$$f'(x) = 1 - \frac{10}{(x-4)^2}$$

$$\text{Let } f'(x) = 0$$

$$0 = 1 - \frac{10}{(x-4)^2}$$

$$0 = (x-4)^2 - 10$$

$$(x-4)^2 = 10$$

$$x = 4 \pm \sqrt{10}$$

Therefore there are two stationary points.

(v)

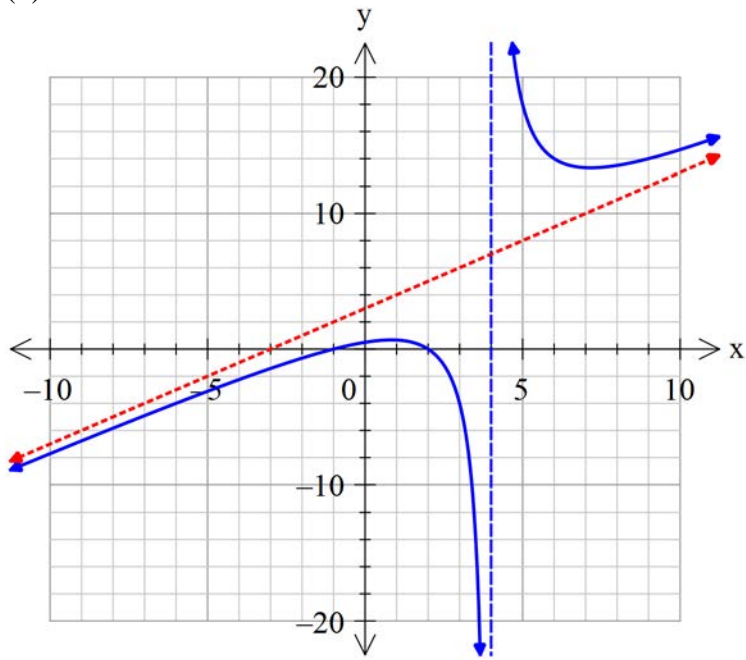

(b)

(i)

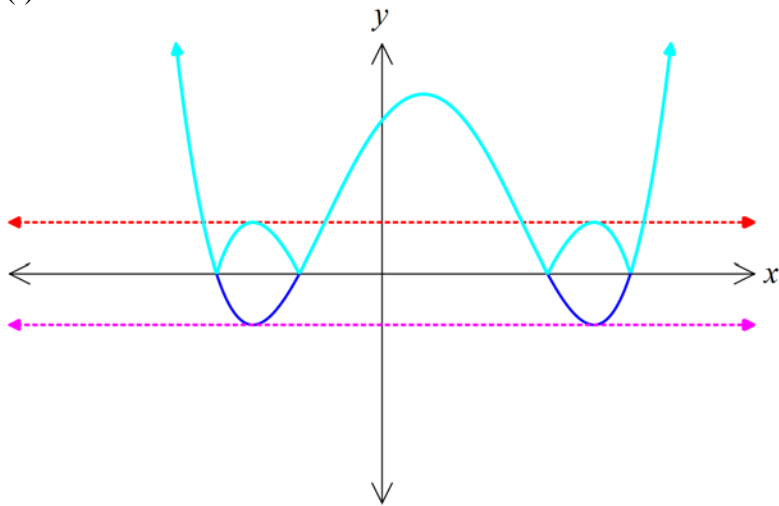

(ii)

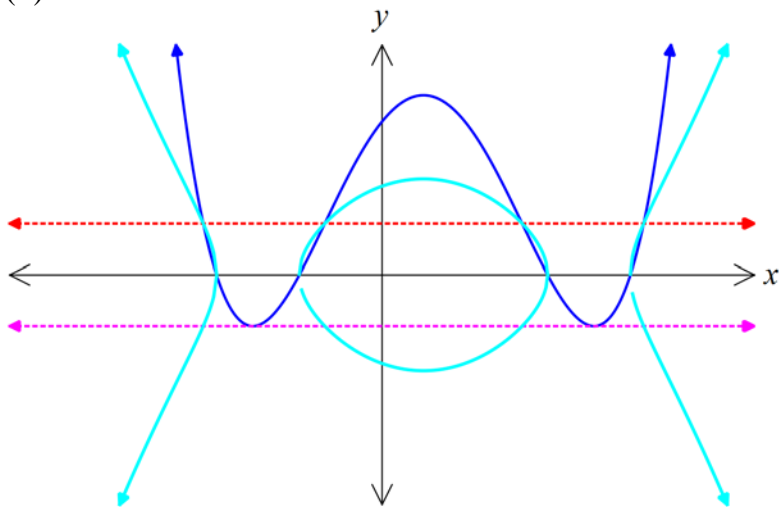

(iii)

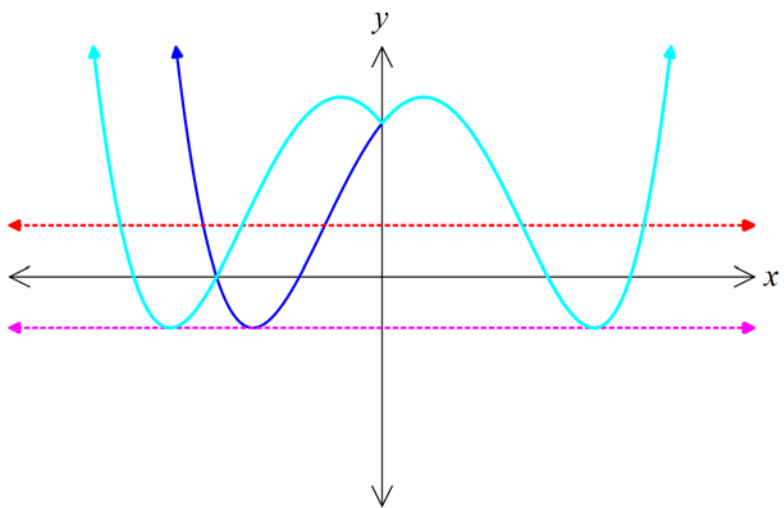

Question 15

(a)

(i)

$$x = a - y$$

$$dx = -dy$$

When $x = 0$, $y = a$

When $x = 1$, $y = 0$

$$\int_0^a f(x) dx = - \int_a^0 f(a-y) dy$$

$$= \int_0^a f(a-y) dy$$

$$= \int_0^a f(x-a) dx$$

(ii)

$$f(x) = x(1-x)^{20}$$

$$f(1-x) = (1-x)(1-(1-x))^{20}$$

$$= (1-x)x^{20}$$

$$\int_0^1 x(1-x)^{20} dx = \int_0^1 (1-x)x^{20} dx$$

$$= \int_0^1 (x^{20} - x^{21}) dx$$

$$= \left[\frac{x^{21}}{21} - \frac{x^{22}}{22} \right]_0^1$$

$$= \frac{1}{21} - \frac{1}{22}$$

$$= \frac{1}{462}$$

(b)

(i)

Let $\angle TAB = \alpha$

$\angle MAX = \alpha$ (vertically opposite angles)

$\angle APX = \alpha$ (angle in the alternate segment)

$\angle BPT = \alpha$ (vertically opposite angles)

$\angle NBH = \alpha$ (angle in the alternate segment theorem)

$\angle TBA = \alpha$ (vertically opposite angles)

$\therefore \angle TAB = \angle TBA$

$\therefore AT = BT$ (equal sides opposite equal angles in an isosceles triangle)

(ii)

$\angle BPA + \alpha = 180^\circ$ (angles on the straight line)

$\angle BPA = 180^\circ - \alpha$

$\angle ATB + 2\alpha = 180^\circ$ (angle sum of a triangle)

$\angle ATB = 180^\circ - 2\alpha$

$\angle BPA + \angle ATB = 180^\circ$ (opposite angles of a cyclic quadrilateral are equal).

$$180^\circ - \alpha + 180^\circ - 2\alpha = 180^\circ$$

$$360^\circ - 3\alpha = 180^\circ$$

$$3\alpha = 180^\circ$$

$$\alpha = 60^\circ$$

$$\therefore \angle TAB = 60^\circ$$

(c)

(i)

$$u = -x$$

$$du = -dx$$

$$\text{When } x = -2, u = 2$$

$$\text{When } x = 2, u = -2$$

$$\begin{aligned} \int_{-2}^2 \frac{x^2}{e^x + 1} dx &= -\int_2^{-2} \frac{u^2}{e^{-u} + 1} du \\ &= \int_{-2}^2 \frac{u^2 e^u}{1 + e^u} du \\ &= \int_{-2}^2 \frac{x^2 e^x}{1 + e^x} dx \end{aligned}$$

(ii)

$$\text{Let } I = \int_{-2}^2 \frac{x^2}{e^x + 1} dx$$

$$2I = \int_{-2}^2 \frac{x^2}{e^x + 1} dx + \int_{-2}^2 \frac{x^2 e^x}{e^x + 1} dx$$

$$= \int_{-2}^2 \frac{x^2 + x^2 e^x}{e^x + 1} dx$$

$$= \int_{-2}^2 x^2 dx$$

$$= 2 \int_0^2 x^2 dx$$

$$= 2 \left[\frac{x^3}{3} \right]_0^2$$

$$= 2 \times \frac{8}{3}$$

$$= \frac{16}{3}$$

$$\therefore I = \frac{8}{3}$$

(d)

(i)

$T\left(\frac{a}{e}, \frac{a}{e}\right)$ as it lies on the line $y = x$ and the directrix $x = \frac{a}{e}$.

$\therefore PQ$ has equation:

$$\frac{x}{a^2} \times \frac{a}{e} + \frac{y}{b^2} \times \frac{a}{e} = 1$$

$$\frac{x}{ae} + \frac{ay}{e} \times \frac{1}{a^2(1-e^2)} = 1 \text{ since } b^2 = a^2(1-e^2)$$

$$\frac{x}{ae} + \frac{y}{ae(1-e^2)} = 1$$

Sub $S(ae, 0)$

$$LHS = \frac{ae}{ae} + 0$$

$$= 1$$

$$= RHS$$

Therefore PQ is a focal chord.

(ii)

$$\frac{x^2}{a^2} + \frac{y^2}{a^2(1-e^2)} = 1 \dots (1)$$

$$\frac{x}{ae} + \frac{y}{ae(1-e^2)} = 1 \dots (2)$$

From (2)

$$\frac{y}{ae(1-e^2)} = 1 - \frac{x}{ae}$$

$$\frac{y}{ae(1-e^2)} = \frac{ae-x}{ae}$$

$$y = (ae-x)(1-e^2)$$

$$\therefore y^2 = (ae-x)^2(1-e^2)^2$$

Substitute into (1)

$$\frac{x^2}{a^2} + \frac{(ae-x)^2(1-e^2)^2}{a^2(1-e^2)} = 1$$

$$x^2 + (ae-x)^2(1-e^2) = a^2$$

$$x^2 + (a^2e^2 - 2aex + x^2)(1-e^2) = a^2$$

$$x^2 + a^2e^2 - 2aex + x^2 - a^2e^4 + 2ae^3x - e^2x^2 - a^2 = 0$$

$$2x^2 - e^2x^2 - 2aex + 2ae^3x + a^2e^2 - a^2e^4 - a^2 = 0$$

$$(2-e^2)x^2 - 2ae(x-e^2x) + a^2(e^2-e^4-1) = 0$$

$$(2-e^2)x^2 - 2aex(1-e^2) + a^2(e^2-e^4-1) = 0$$

x_1 and x_2 are the roots of this equation as $P(x_1, y_1)$ and $Q(x_2, y_2)$ are the points of intersection of (1) and

(2)

(iii)

$$x_M = \frac{x_1 + x_2}{2}$$

$$\text{From (ii), } x_1 + x_2 = \frac{2ae(1-e^2)}{2-e^2}$$

$$\frac{x_1 + x_2}{2} = \frac{ae(1-e^2)}{2-e^2}$$

M lies on PQ : Sub in $M(x_M, y_M)$

$$\frac{ae(1-e^2)}{2-e^2} \times \frac{1}{ae} + \frac{y_M}{ae(1-e^2)} = 1$$

$$\frac{1-e^2}{2-e^2} + \frac{y_M}{ae(1-e^2)} = 1$$

$$\frac{y_M}{ae(1-e^2)} = 1 - \frac{1-e^2}{2-e^2}$$

$$\frac{y_M}{ae(1-e^2)} = \frac{2-e^2-1+e^2}{2-e^2}$$

$$\frac{y_M}{ae(1-e^2)} = \frac{1}{2-e^2}$$

$$y_M = \frac{ae(1-e^2)}{2-e^2}$$

$$= x_M$$

$\therefore M$ lies on the line $y = x$.

Question 16

(a)

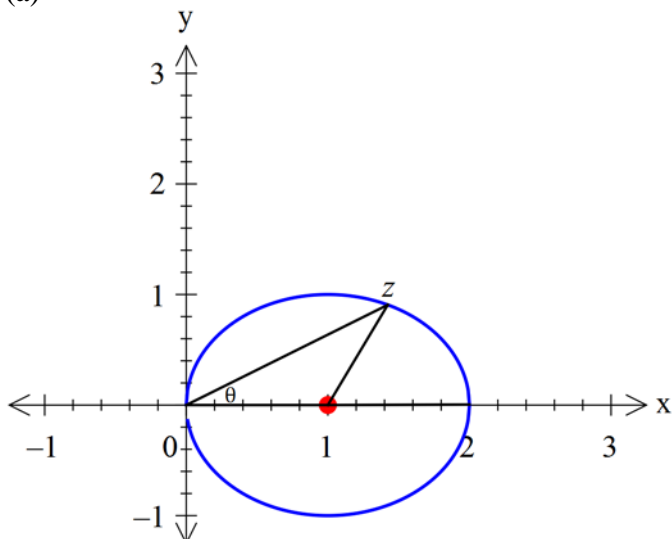

$$\arg(z) = \theta$$

$z-1$ is the vector from 1 to z

Let $\arg(z-1) = \beta$

$2\theta = \beta$ (angle at the centre is twice the angle at the circumference, subtended by the same arc)

$$\arg(z-1) = 2\theta$$

(ii)

$$\arg(z^2 - 3z + 2) = \arg[(z-2)(z-1)]$$

$$= \arg(z-2) + \arg(z-1)$$

$z-2$ is the vector from 2 to z

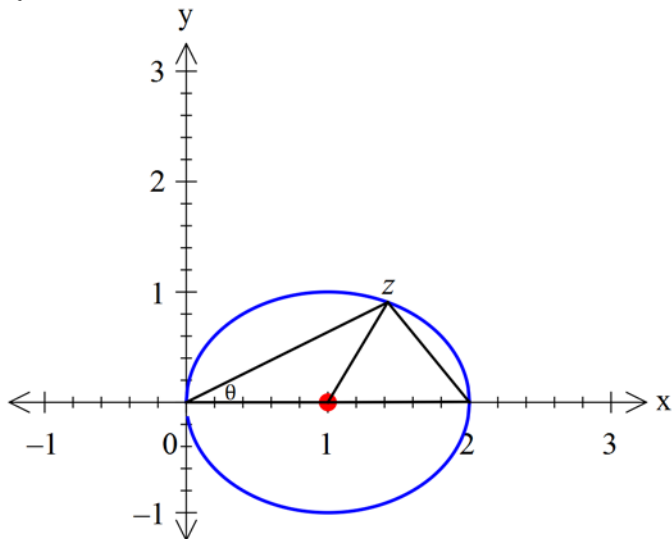

The angle between the vector z and $z-2$ is $\frac{\pi}{2}$ (angle in semicircle)

$$\arg(z-2) = \frac{\pi}{2} + \theta \quad (\text{exterior angle of a triangle})$$

$$\arg(z^2 - 3z + 2) = \frac{\pi}{2} + \theta + 2\theta$$

$$= \frac{\pi}{2} + 3\theta$$

(b)

(i)

$$\begin{aligned}(a+b)\left(\frac{1}{a}+\frac{1}{b}\right) &= \frac{a}{a} + \frac{a}{b} + \frac{b}{a} + \frac{b}{b} \\ &= 2 + \frac{a}{b} + \frac{b}{a}\end{aligned}$$

But

$$a + \frac{1}{a} \geq 2$$

$$\therefore \frac{a}{b} + \frac{b}{a} \geq 2$$

$$\begin{aligned}(a+b)\left(\frac{1}{a}+\frac{1}{b}\right) &= 2 + \frac{a}{b} + \frac{b}{a} \\ &\geq 4\end{aligned}$$

(ii)

$$(a+b)\left(\frac{1}{a}+\frac{1}{b}\right) \geq 4$$

$$(b+c)\left(\frac{1}{b}+\frac{1}{c}\right) \geq 4$$

$$(c+a)\left(\frac{1}{c}+\frac{1}{a}\right) \geq 4$$

$$(a+b)\left(\frac{1}{a}+\frac{1}{b}\right)(b+c)\left(\frac{1}{b}+\frac{1}{c}\right)(c+a)\left(\frac{1}{c}+\frac{1}{a}\right) \geq 64$$

$$(a+b)(b+c)(c+a)\left(\frac{1}{a}+\frac{1}{b}\right)\left(\frac{1}{b}+\frac{1}{c}\right)\left(\frac{1}{c}+\frac{1}{a}\right) \geq 64$$

$$(a+b)(b+c)(c+a)\left(\frac{b+a}{ab}\right)\left(\frac{c+b}{bc}\right)\left(\frac{c+a}{ca}\right) \geq 64$$

$$(a+b)^2(b+c)^2(c+a)^2 \geq 64ab \times bc \times ca$$

$$[(a+b)(b+c)(c+a)]^2 \geq (8abc)^2$$

$$\therefore (a+b)(b+c)(c+a) \geq 8abc$$

(c)

(i)

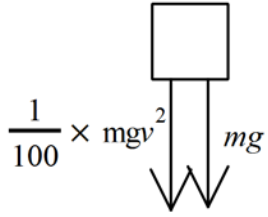

$$m\ddot{x} = \frac{-1}{100}mgv^2 - mg$$

$$\ddot{x} = \frac{-1}{100}gv^2 - g$$

$$= \frac{-1}{100}gv^2 - \frac{100g}{100}$$

$$= -\frac{1}{100}g(v^2 + 100)$$

(ii)

$$v \cdot \frac{dv}{dx} = \frac{-1}{100}g(v^2 + 100)$$

$$\frac{dv}{dx} = \frac{-1}{100}g \left(\frac{v^2 + 100}{v} \right)$$

$$\frac{dx}{dv} = -100g \left(\frac{v}{v^2 + 100} \right)$$

$$x = -50g \int \frac{2v}{v^2 + 100} dv$$

$$= -50g \ln(v^2 + 100) + C$$

When $x = 0$, $v = u$

$$0 = \frac{-50}{g} \ln(u^2 + 100) + c$$

$$c = \frac{50}{g} \ln(u^2 + 100)$$

$$x = \frac{-50}{g} \ln(v^2 + 100) + \frac{50}{g} \ln(u^2 + 100)$$

Let $v = 0$

$$x = -\frac{50}{g} \ln 100 + \frac{50}{g} \ln(u^2 + 100)$$

$$= 50g (\ln(u^2 + 100) - \ln 100)$$

$$= 50g \ln \left(\frac{u^2 + 100}{100} \right)$$

(iii)

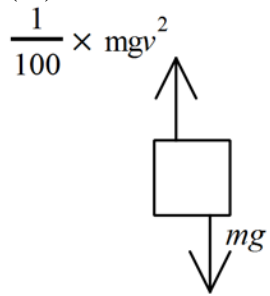

$$m\ddot{x} = mg - \frac{1}{100}mgv^2$$

$$\ddot{x} = g - \frac{1}{100}gv^2$$

$$= \frac{100g}{100} - \frac{1}{100}gv^2$$

$$= \frac{1}{100}(100g - gv^2)$$

$$= \frac{g}{100}(100 - v^2)$$

(iv)

$$v \frac{dv}{dx} = \frac{1}{100}g(100 - v^2)$$

$$\frac{dv}{dx} = \frac{1}{100}g \left(\frac{100 - v^2}{v} \right)$$

$$\frac{dx}{dv} = \frac{100}{g} \left(\frac{v}{100 - v^2} \right)$$

$$x = \frac{-50}{g} \int \frac{-2v}{100 - v^2} dv$$

$$= \frac{-50}{g} \ln(100 - v^2) + C$$

When $x = 0, v = 0$

$$0 = -\frac{50}{g} \ln 100 + c$$

$$c = \frac{50}{g} \ln 100$$

$$x = -\frac{50}{g} \ln(100 - v^2) + \frac{50}{g} \ln 100$$

$$= \frac{50}{g} \ln \left(\frac{100}{100 - v^2} \right)$$

$$\text{Let } x = \frac{50}{g} \ln \left(\frac{100 + u^2}{100} \right)$$

$$\frac{100+u^2}{100} = \frac{100}{100-v^2}$$

$$100-v^2 = \frac{100^2}{100+u^2}$$

$$v^2 = 100 - \frac{100^2}{100+u^2}$$

$$v^2 = \frac{100^2 + 100u^2 - 100^2}{100+u^2}$$

$$v^2 = \frac{100u^2}{100+u^2}$$

$$v = \frac{10u}{\sqrt{100+u^2}} \text{ since } u > 0$$

(v)

Let $\ddot{x} = 0, V = v$

$$0 = \frac{1}{100} g(100 - V^2)$$

$$100 - V^2 = 0$$

$$V^2 = 100$$

$$V = 10 \quad (V > 0)$$

(vi)

Let $u = V$

$$\frac{10V}{\sqrt{100+V^2}} = \frac{100}{\sqrt{100+100}}$$

$$= \frac{100}{\sqrt{200}}$$

$$= \frac{100}{10\sqrt{2}}$$

$$= \frac{10}{\sqrt{2}}$$

$$= \frac{1}{\sqrt{2}} V$$