

2014  
HSC  
ASSESSMENT TASK 4

Trial HSC Examination

# Mathematics Extension 2

Examiners ~ Mr. J. Dillon, Mr. S. Gee, Mr. G. Rawson

## General Instructions

- Reading Time – 5 minutes
- Working Time – 3 hours
- Write using a blue or black pen.
- Board approved calculators and mathematical templates and instruments may be used.
- Show all necessary working in Questions 11 – 16.
- This examination booklet consists of 19 pages including a standard integral page and multiple choice answer sheet.

Total marks (100)

### Section I

Total marks (10)

- Attempt Questions 1 – 10
- Answer on the Multiple Choice answer sheet provided.
- Allow 15 minutes for this section.

### Section II

Total marks (90)

- Attempt questions 11 – 16
- Answer each question in the Writing Booklets provided.
- Start a new booklet for each question with your student number and question number at the top of the page.
- All necessary working should be shown for every question.
- Allow 2 hours 45 minutes for this section.

Name and Student Number : \_\_\_\_\_

Teacher : \_\_\_\_\_

## Section I

10 marks

Attempt Questions 1 – 10

Allow about 15 minutes for this section

Use the multiple choice answer sheet for Questions 1 – 10.

---

1. Which of the following is an expression for  $\int \frac{1}{\sqrt{7-6x-x^2}} dx$ ?

(A)  $\sin^{-1}\left(\frac{x-3}{2}\right) + c$

(B)  $\sin^{-1}\left(\frac{x+3}{2}\right) + c$

(C)  $\sin^{-1}\left(\frac{x-3}{4}\right) + c$

(D)  $\sin^{-1}\left(\frac{x+3}{4}\right) + c$

2. Suppose  $f(x)$  is a continuous smooth function over  $a \leq x \leq b$ , and  $g(x)$  is a continuous smooth function over  $c \leq x \leq d$ .

Which of the following integrals is always greater than, or equal to, the other choices?

(A)  $\int_a^b f(x) dx + \int_c^d g(x) dx$

(B)  $\int_a^b |f(x)| dx + \int_c^d |g(x)| dx$

(C)  $\left| \int_a^b f(x) dx \right| + \left| \int_c^d g(x) dx \right|$

(D)  $\left| \int_a^b f(x) dx + \int_c^d g(x) dx \right|$

3. If  $z$  represents a variable point on the argand diagram, which description best represents the locus of  $|z-4+i| - |z+4-i| = 0$ ?

(A) a hyperbola

(B) an ellipse

(C) a circle

(D) a line

4. The polynomial  $P(x) = a_n x^n + a_{n-1} x^{n-1} + \dots + a_0$  is an odd polynomial with at least 1 multiple root.

John was asked to give some facts about the curve  $y = P(x)$  and replied

- (i)  $y = P(x)$  must pass through the origin.
- (ii) If  $P'(a) = 0$  then  $P(-a) = 0$

Which of John's statements must always be correct?

- (A) (i) only
- (B) (ii) only
- (C) both (i) and (ii)
- (D) neither (i) or (ii)

5. If  $\omega$  is a complex cube root of unity, which of the following results is NOT correct?

- (A)  $\omega^2$  is the other complex root
- (B)  $\omega^2 + \omega = -1$
- (C)  $\omega^6 - \omega = \omega^2$
- (D)  $\bar{\omega}$  is also a root

6. What are the coordinates of the foci of the conic section:  $\frac{x^2}{9} - \frac{y^2}{16} = 1$  ?

- (A)  $(0, \pm 5)$
- (B)  $(\pm 5, 0)$
- (C)  $(\pm \sqrt{5}, 0)$
- (D)  $(0, \pm \sqrt{5})$

7. The diagram below shows the graph of the function  $y = f(x)$ .

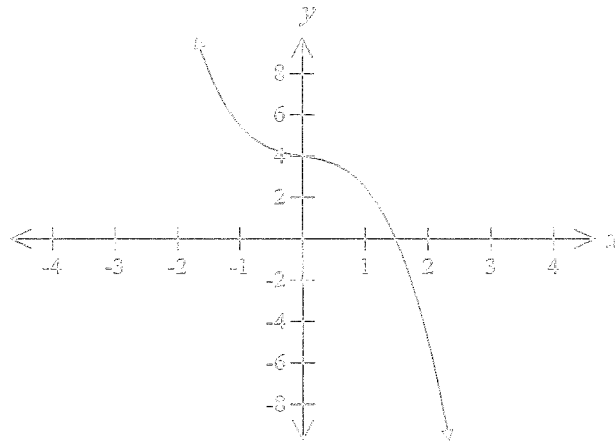

Which diagram represents the graph of  $y^2 = f(x)$ ?

(A)

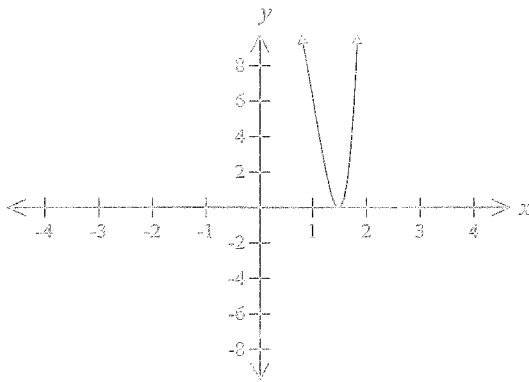

(B)

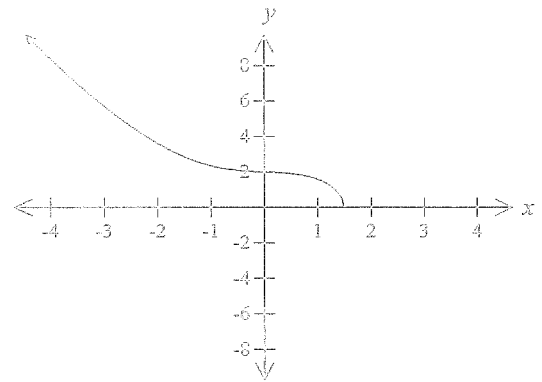

(C)

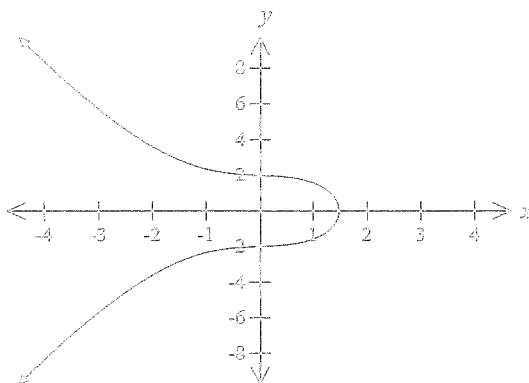

(D)

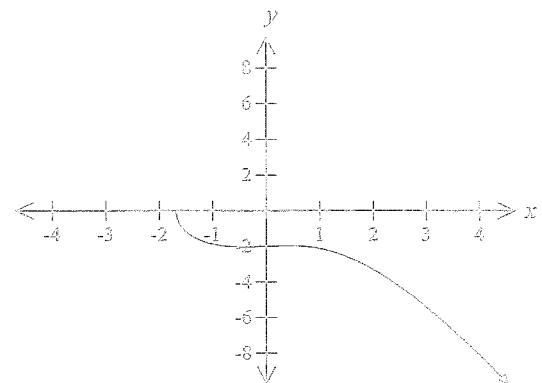

3. The diagram shows the graph of the function  $y = f(x)$ .

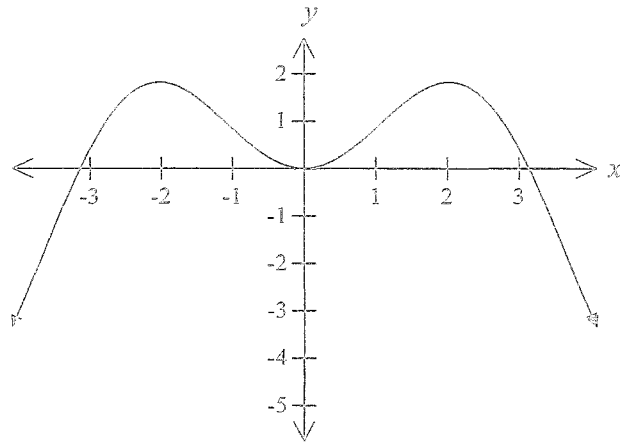

Which of the following is the graph of  $y = |f(x)|$ ?

(A)

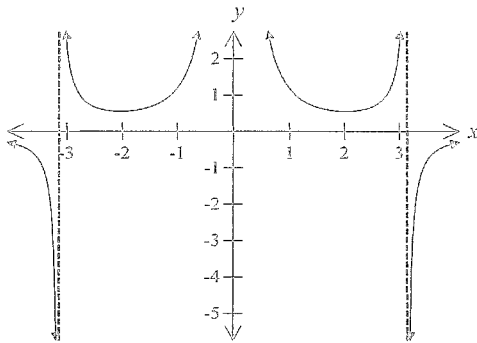

(B)

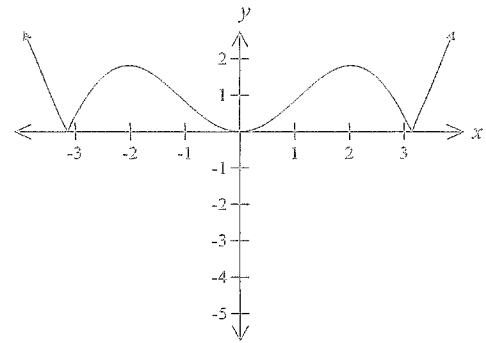

(C)

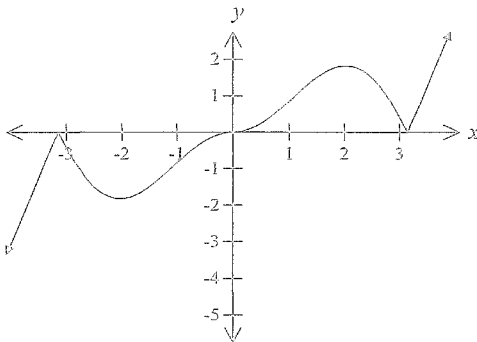

(D)

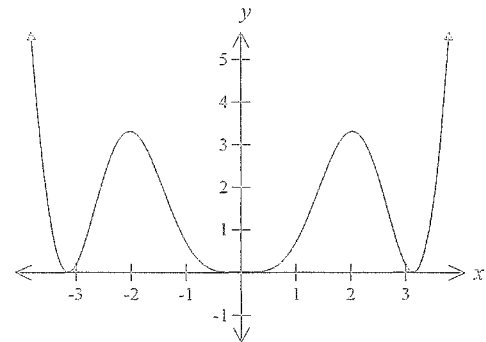

9. A mass of 1 kg is released from rest at the surface in which the retardation on the mass is proportional to the distance fallen ( $x$ ). The net force for this motion is  $g - kx$  Newtons, with the downward direction as positive.

The mass will have constant velocity after falling how far?

- (A)  $\frac{g}{k}$                       (B)  $\frac{3g}{k}$                       (C)  $\frac{kv}{g}$                       (D)  $\frac{2g}{kv}$

10.

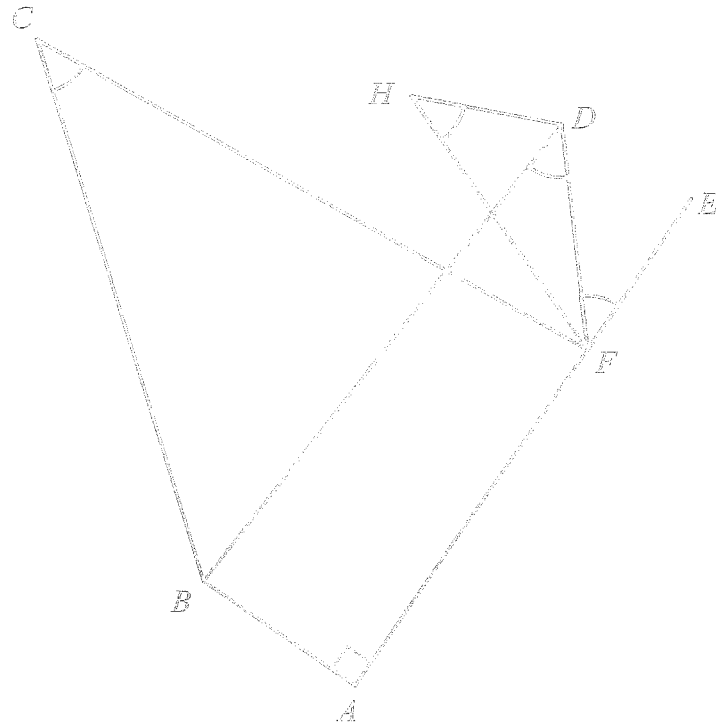

In the diagram above, all equal angles are marked and  $AFE$  is a straight line.

Which of these statements is INCORRECT?

- (A) A circle may be drawn through  $A, B, H$  and  $F$  with diameter  $BF$   
 (B) The points  $B, C, D, F$  are concyclic  
 (C) A circle may be drawn through  $D, F$  and  $H$  with tangent  $AE$   
 (D) A circle may be drawn through  $B, H, D$  and  $F$  with tangent  $AE$

### Section III

90 marks

Attempt Questions 11 – 16

Allow about 2 hours 45 minutes for this section

Answer each question in the appropriate writing booklet.

All necessary working should be shown in every question.

---

Question 11 (15 marks)	Start a new booklet	Marks
------------------------	---------------------	-------

(a)	Find $\int \cos^3 x \, dx$	2
-----	----------------------------	---

(b)	Use the technique of integration by parts to find: $\int e^x \cos x \, dx$	3
-----	--	---

(c)	Use partial fractions to find: $\int \frac{4 \, dx}{4x^2 - 1}$	2
-----	--	---

(d)	Find $\int \sqrt{\frac{x-1}{x+1}} \, dx$	2
-----	--	---

(e)	(i) Show that a reduction formula for $I_n = \int x^n \cos x \, dx$ is $I_n = x^n \sin x + nx^{n-1} \cos x - n(n-1)I_{n-2}$	3
-----	--	---

(ii)	Hence, or otherwise, evaluate $\int_0^{\frac{\pi}{2}} x^4 \cos x \, dx$	3
------	---	---

- (a)  $P$  is the point on the argand diagram representing the complex number  $Z=1+i$ ,  
 $Q = iZ, R = -Z$  and  $T = \frac{1}{Z}$ .
- (i) Find the values of  $Q, R,$  and  $T,$  expressing each in the form  $x+iy$  with  $x$  and  $y$  real. 2
- (ii) Locate  $P, Q, R$  and  $T$  on the argand diagram. 2  
 What is the best description of quadrilateral  $PQRT$ ?
- (b) On the argand diagram, let  $A = 3 + 4i$  and  $B = 9 + 4i$
- (i) Draw a clear sketch to show the important features of the curve defined by  $|z - A| = 5$ . 2  
 For  $z$  on this curve find the maximum value of  $|z|$ .
- (ii) On a separate diagram draw a clear sketch to show the important features of the curve defined by  $|z - A| + |z - B| = 12$ . 2  
 For  $z$  on this curve find the greatest value of  $\arg(z)$ .
- (c) (i) Express  $w = \sqrt{2} - i\sqrt{2}$  in modulus-argument form. 1
- (ii) Hence write  $w^{22}$  in the form  $a+ib$ , where  $a$  and  $b$  are real. 1
- (d) (i) Find the six sixth roots of  $-1$  expressing each in the form  $x+iy$  with  $x$  and  $y$  real. 2
- (ii) Hence, or otherwise, find the four roots of the equation 2  
 $z^4 - z^2 + 1 = 0$ .
- (iii) Indicate the solutions to part (ii) on the argand diagram. 1



- (a) With respect to the  $Ox$  and  $Oy$  axes, the line  $x = 1$  is a directrix, and the point  $(2, 0)$  is a focus of a conic of eccentricity  $\sqrt{2}$ .
- (i)  $(\alpha)$  Using the definition of a conic,  $PS = ePM$ , find the equation of the conic. 1
- $(\beta)$  Prove the conic is a rectangular hyperbola. 1
- $(\gamma)$  Sketch the curve, indicating its asymptotes, foci and directrices. 1
- (ii) Find the equation of the normal to the curve at any point  $P$  on it. 1
- (iii) The normal to the curve at  $P$  meets the  $x$  and  $y$  axes in  $(X, 0)$  and  $(0, Y)$  respectively.  $T$  is the point  $(X, Y)$ . 2

Show that as  $P$  varies on the curve,  $T$  always lies on the hyperbola  $x^2 - y^2 = 8$

- (b) Let  $C_1 \equiv x^2 + 3y^2 - 1$ ,  $C_2 \equiv 4x^2 + y^2 - 1$ , and let  $\lambda$  be any real number.
- (i) Show that  $C_1 + \lambda C_2 = 0$  is the equation of a curve through the point of intersection of the ellipses  $C_1 = 0$  and  $C_2 = 0$ . 2
- (ii) Determine the values of  $\lambda$  for which  $C_1 + \lambda C_2 = 0$  is the equation of an ellipse. 2
- (c) (i) If  $\alpha$  is a multiple root of the polynomial equation  $P(x) = 0$ , prove that  $P'(\alpha) = 0$ . 1
- (ii) Find all roots of the equation  $18x^3 + 3x^2 - 28x + 12 = 0$  given that two of the roots are equal. 2
- (d) If  $\alpha, \beta$  and  $\delta$  are the roots of  $2x^3 - x^2 + 3x + 5 = 0$ , find the equation with roots  $\frac{1}{\alpha}, \frac{1}{\beta}$  and  $\frac{1}{\delta}$ . 2

- (a) The circle  $x^2 + y^2 = 16$  is rotated about the line  $x = 9$  to form a ring, i.e. a torus.

When the circle is rotated, the line segment  $S$  at height  $y$  sweeps out an annulus.

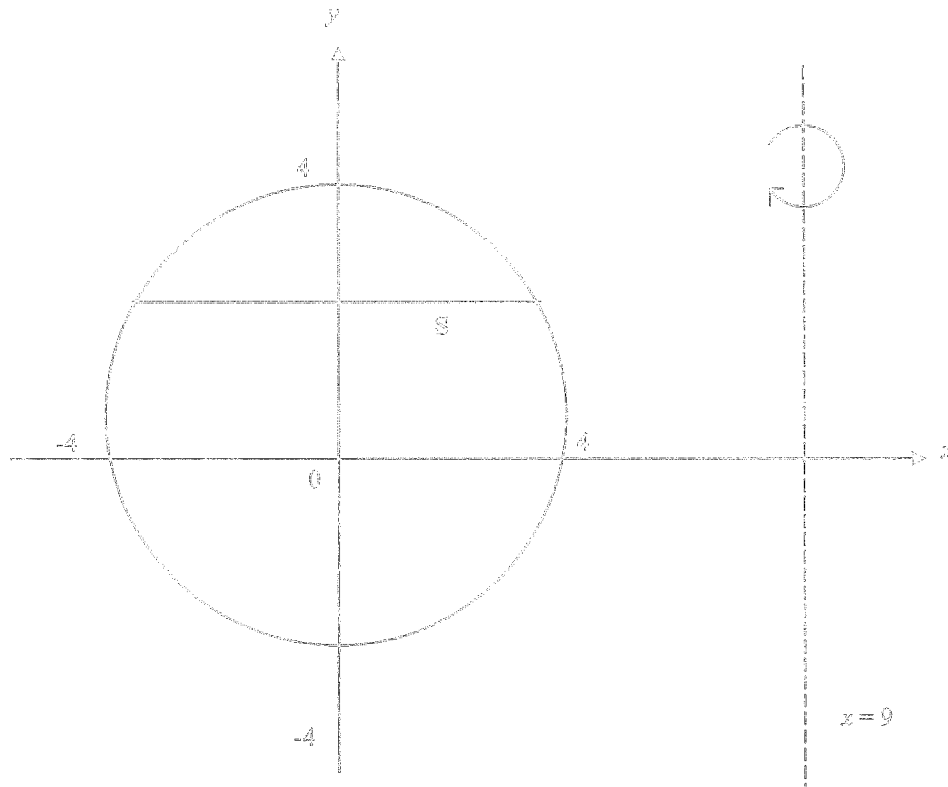

- (i) Show that the area of the annulus is equal to  $36\pi\sqrt{16 - y^2}$ . 3
- (ii) Hence, find the volume of the ring. 3

Question 14 continues on the next page .....

- (b) Let  $S$  be a solid where the base is the region bounded by the circle  $x^2 + y^2 = 25$  and each cross-section taken perpendicular to the  $x$ -axis is a square.

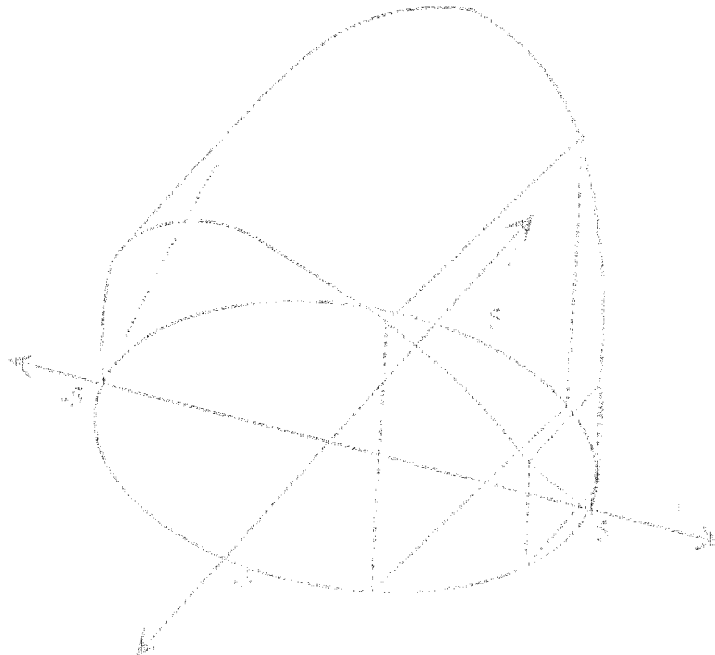

Find the volume of the solid  $S$ .

4

- (c) The region bounded by the curve  $y = \frac{1}{(2x+1)(x+1)}$ , the coordinate axes and the line  $x = 4$  is rotated through one complete revolution about the  $y$ -axis.

- (i) Use the method of cylindrical shells to show that the volume of the resulting solid of revolution can be written as the integral

$$V = 2\pi \int_0^4 \frac{x}{(2x+1)(x+1)} dx \quad 3$$

- (ii) Calculate the integral in (i) to determine the volume.

2

(a)

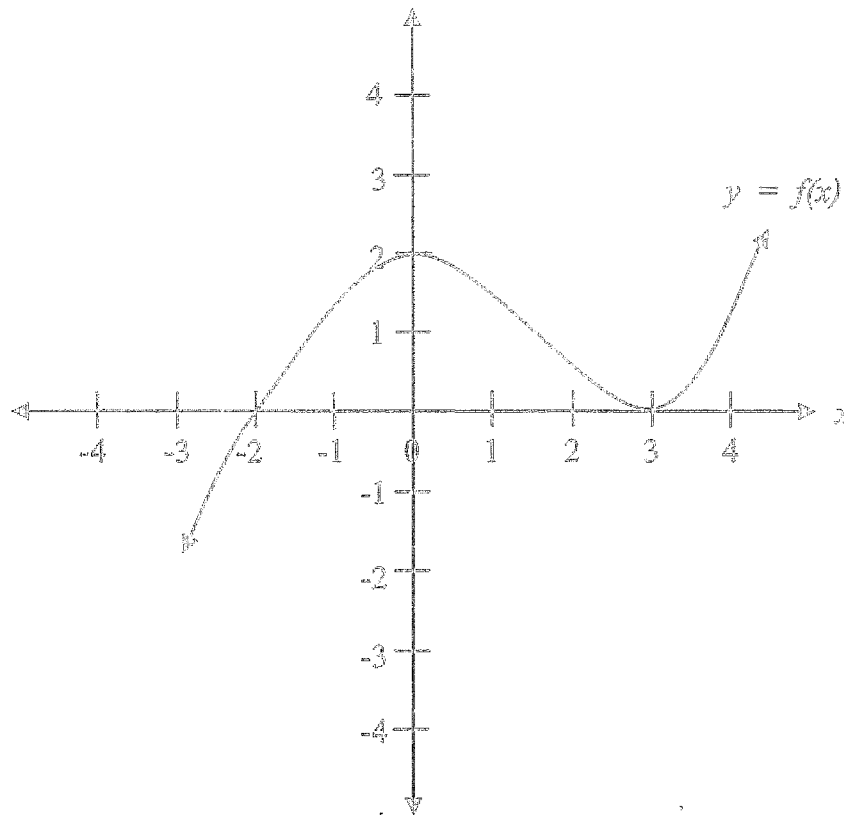

Given the above graph  $y = f(x)$ , draw separate sketches of the following graphs showing all critical points.

Ensure that you copy, or trace, the above diagram into your answer booklet to assist you with producing your graphs.

(i)  $y = \frac{1}{f(x)}$  2

(ii)  $y = |f(|x|)|$  2

(iii)  $|y| = f(x)$  2

(iv)  $y = \ln[f(x)]$  2

(b) A particle of unit mass moves in a straight line against a resistance numerically equal to  $v + v^3$ , where  $v$  is its velocity. Initially the particle is at the origin and is travelling with velocity  $Q$ , where  $Q > 0$ .

(i) Explain why  $\ddot{x} = -(v + v^3)$  1

(ii) Show that  $v$  is related to the displacement  $x$  by the formula

$$x = \tan^{-1} \left[ \frac{Q - v}{1 + Qv} \right].$$
2

(iii) Show that the time  $t$  which has elapsed when the particle is travelling

with velocity  $V$  is given by  $t = \frac{1}{2} \log_e \left[ \frac{Q^2 (1 + V^2)}{V^2 (1 + Q^2)} \right]$ . 2

(iv) Find  $V^2$  as a function of  $t$ . 2

- (a)  $A$  and  $B$  are two points on a circle.  
 Tangents at  $A$  and  $B$  meet at  $C$ .  
 A third tangent cuts  $CA$  and  $CB$  in  $P$  and  $Q$  respectively, as shown in the diagram.

3

Copy, or trace the diagram into your answer booklet.

Show that the perimeter of  $\triangle CPQ$  is constant and independent of  $PQ$ .

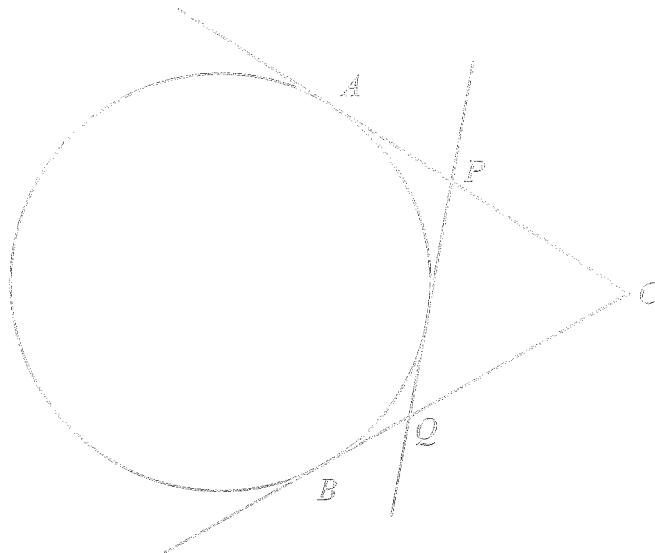

- (b) Consider the function  $f(x) = \frac{(n+1+x)^{n+1}}{(n+x)^n}$ ,  $x \geq 0$  where  $n \geq 1$  is a fixed positive integer.

- (i) Show that for  $x > 0$ ,  $f(x)$  is an increasing function of  $x$ . 2
- (ii) Hence, show that  $\left(1 + \frac{x}{n+1}\right)^{n+1} > \left(1 + \frac{x}{n}\right)^n$ . 2
- (iii) Deduce that  $(n+2)^{n+1} n^n > (n+1)^{2n+1}$ . 2

Question 16 continues on the next page .....

(c)

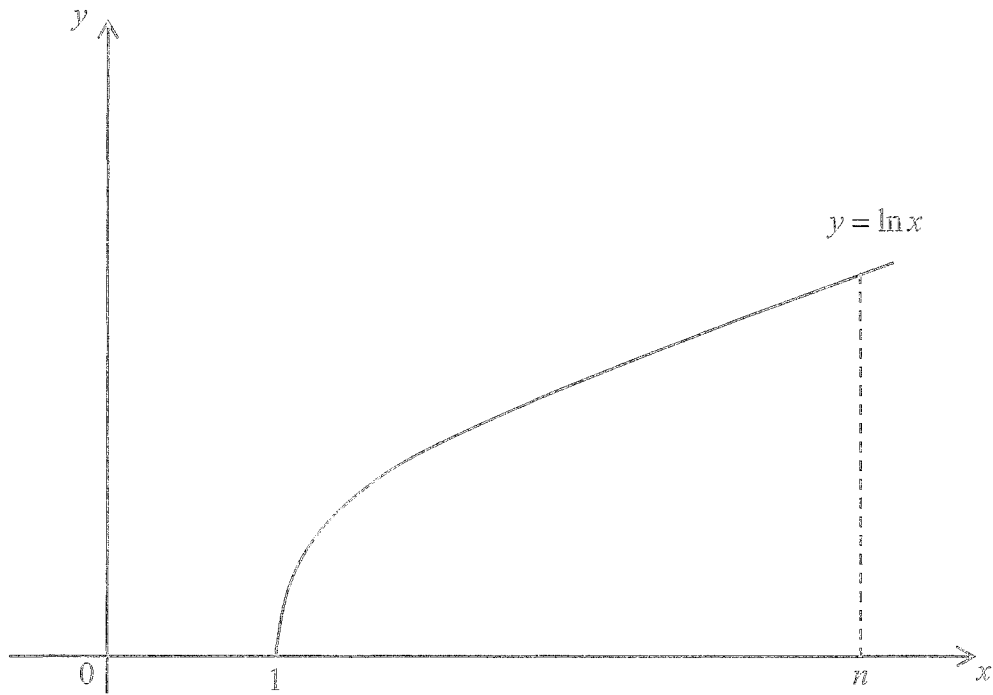

- (i) Use the trapezoidal rule with  $n$  function values to approximate  $\int_1^n \ln x \, dx$  2
- (ii) Show that  $\frac{d}{dx}(x \ln x - x) = \ln x$ , and hence find the exact value of  $\int_1^n \ln x \, dx$  2
- (iii) Deduce that  $\ln n! < \left(n + \frac{1}{2}\right) \ln n - n + 1$  2

END OF EXAMINATION

This page has been left blank intentionally



## STANDARD INTEGRALS

$$\int x^n dx = \frac{1}{n+1} x^{n+1}, \quad n \neq -1; \quad x \neq 0, \text{ if } n < 0$$

$$\int \frac{1}{x} dx = \ln x, \quad x > 0$$

$$\int e^{ax} dx = \frac{1}{a} e^{ax}, \quad a \neq 0$$

$$\int \cos ax dx = \frac{1}{a} \sin ax, \quad a \neq 0$$

$$\int \sin ax dx = -\frac{1}{a} \cos ax, \quad a \neq 0$$

$$\int \sec^2 ax dx = \frac{1}{a} \tan ax, \quad a \neq 0$$

$$\int \sec ax \tan ax dx = \frac{1}{a} \sec ax, \quad a \neq 0$$

$$\int \frac{1}{a^2 + x^2} dx = \frac{1}{a} \tan^{-1} \frac{x}{a}, \quad a \neq 0$$

$$\int \frac{1}{\sqrt{a^2 - x^2}} dx = \sin^{-1} \frac{x}{a}, \quad a > 0, \quad -a < x < a$$

$$\int \frac{1}{\sqrt{x^2 - a^2}} dx = \ln \left( x + \sqrt{x^2 - a^2} \right), \quad x > a > 0$$

$$\int \frac{1}{\sqrt{x^2 + a^2}} dx = \ln \left( x + \sqrt{x^2 + a^2} \right)$$

NOTE:  $\ln x = \log_e x$ ,  $x > 0$



Year 12 Extension 2 Mathematics		TRIAL HSC 2014
Question 11.11 Solutions and Marking Guidelines		
Outcomes Addressed in this Question		
E8 - applies further techniques of integration, including partial fractions, integration by parts and recurrence formulae, to problems.		
Outcome	Solutions	Marking Guidelines
	<p>(a) <math>\int \cos^3 x \, dx = \int \cos^2 x \cos x \, dx</math>  <math>= \int (1 - \sin^2 x) \cos x \, dx</math>     <math>\left  \begin{array}{l} u = \sin x \\ du = \cos x \, dx \end{array} \right.</math>  <math>= \int (1 - u^2) \, du</math>  <math>= u - \frac{u^3}{3} + C</math>  <math>= \sin x - \frac{\sin^3 x}{3} + C</math></p>	<p><u>2 marks</u> : correct solution</p> <p><u>1 mark</u> : substantially correct solution</p>
	<p>(b) <math>I = \int e^x \cos x \, dx</math>     <math>\left  \begin{array}{l} u = e^x \quad dv = \cos x \, dx \\ du = e^x \, dx \quad v = \sin x \end{array} \right.</math>  <math>= uv - \int v \, du</math>  <math>= e^x \sin x - \int e^x \sin x \, dx</math>     <math>\left  \begin{array}{l} u = e^x \quad dv = \sin x \, dx \\ du = e^x \, dx \quad v = -\cos x \end{array} \right.</math>  <math>= e^x \sin x - \left[ -e^x \cos x - \int -e^x \cos x \, dx \right]</math>  <math>= e^x \sin x + e^x \cos x - I</math>  <math>2I = e^x \sin x + e^x \cos x</math>  <math>I = \frac{e^x (\sin x + \cos x)}{2} + c</math></p>	<p><u>3 marks</u> : correct solution</p> <p><u>2 marks</u> : substantially correct solution</p> <p><u>1 mark</u> : correct use of IBP at least once</p>
	<p>(c) <math>\frac{4}{4x^2 - 1} = \frac{4}{(2x-1)(2x+1)} = \frac{A}{2x-1} + \frac{B}{2x+1}</math>  <math>4 = A(2x+1) + B(2x-1)</math>  <math>x = \frac{1}{2} \Rightarrow A = 2</math>  <math>x = -\frac{1}{2} \Rightarrow B = 2</math></p> <p><math>\int \frac{4}{4x^2 - 1} \, dx = \int \frac{2}{2x-1} \, dx - \int \frac{2}{2x+1} \, dx</math>  <math>= \ln 2x-1  - \ln 2x+1  + k</math>  <math>= \ln \left  \frac{2x-1}{2x+1} \right  + k</math></p>	<p><u>2 marks</u> : correct solution</p> <p><u>1 mark</u> : substantially correct solution</p>

<p>Question 11 continued...</p> <p>(d) <math>\int \sqrt{\frac{x-1}{x+1}} \, dx = \int \frac{\sqrt{x-1}}{\sqrt{x+1}} \cdot \frac{\sqrt{x-1}}{\sqrt{x-1}} \, dx</math>  <math>= \int \frac{x-1}{\sqrt{x^2-1}} \, dx</math>  <math>= \int \frac{x}{\sqrt{x^2-1}} \, dx - \int \frac{1}{\sqrt{x^2-1}} \, dx</math>  <math>= \sqrt{x^2-1} - \ln x + \sqrt{x^2-1}  + K</math></p>	<p><u>2 marks</u> : correct solution</p> <p><u>1 mark</u> : substantially correct solution</p>
<p>(e)(i) <math>I_n = \int x^n \cos x \, dx</math>     <math>\left  \begin{array}{l} u = x^n \quad dv = \cos x \, dx \\ du = nx^{n-1} \, dx \quad v = \sin x \end{array} \right.</math>  <math>= uv - \int v \, du</math>  <math>= x^n \sin x - n \int x^{n-1} \sin x \, dx</math>  <math>= x^n \sin x - n \left[ -x^{n-1} \cos x - (n-1) \int -x^{n-2} \cos x \, dx \right]</math>  <math>= x^n \sin x + nx^{n-1} \cos x - n(n-1) \int x^{n-2} \cos x \, dx</math>  <math>= x^n \sin x + nx^{n-1} \cos x - n(n-1)I_{n-2}</math></p>	<p><u>3 marks</u> : correct solution</p> <p><u>2 marks</u> : substantially correct solution</p> <p><u>1 mark</u> : correct use of IBP at least once</p>
<p>(e)(ii) <math>I_3 = \int x^3 \cos x \, dx</math>  <math>= x^4 \sin x + 4x^3 \cos x - 4(3)I_2</math>  <math>= x^4 \sin x + 4x^3 \cos x - 12 \left[ x^2 \sin x + 2x \cos x - 2(1)I_0 \right]</math>  <math>= x^4 \sin x + 4x^3 \cos x - 12x^2 \sin x + 24x \cos x + 24 \int \cos x \, dx</math>  <math>= \left[ x^4 \sin x + 4x^3 \cos x - 12x^2 \sin x + 24x \cos x + 24 \sin x \right]_0^{\frac{\pi}{4}}</math>  <math>= \left[ \left( \frac{\pi}{4} \right)^4 + 0 - 12 \left( \frac{\pi}{2} \right)^2 - 0 + 24(1) \right] - [0]</math>  <math>= \frac{\pi^4}{16} - 3\pi^2 + 24</math></p>	<p><u>3 marks</u> : correct solution</p> <p><u>2 marks</u> : substantially correct solution</p> <p><u>1 mark</u> : meaningful progress towards correct solution</p>

Question No.12-13 Solutions and Marking Guidelines  
**Outcomes Addressed in this Questions**

- E2 chooses appropriate strategies to construct arguments and proofs in both concrete and abstract settings
- E3 uses the relationship between algebraic and geometric representations of complex numbers and of conic sections
- E4 uses efficient techniques for the algebraic manipulation required in dealing with questions such as those involving conic sections and polynomials.
- E6 combines the ideas of algebra and calculus to determine the important features of the graphs of a wide variety of functions
- E7 uses the techniques of slicing and cylindrical shells to determine volumes
- E8 applies further techniques of integration, including partial fractions, integration by parts and recurrence formulae, to problems
- E9 communicates abstract ideas and relationships using appropriate notation and logical argument

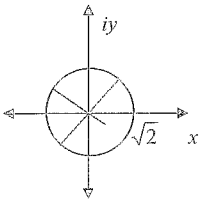
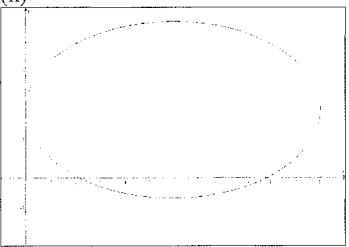
Outcome	Solutions	Marking Guidelines
E3	<p><b>Question 12</b></p> <p>a)</p> <p>(i)</p> <p><math>P = 1 + i</math></p> <p><math>Q = i(1 + i) = -1 + i</math></p> <p><math>R = -(1 + i) = -1 - i</math></p> <div style="display: flex; align-items: center; justify-content: center;"> <div style="margin-right: 20px;"> <p><math>T = \frac{1}{\sqrt{2}} \text{cis}\left(-\frac{\pi}{4}\right)</math></p> <p><math>\frac{1}{\sqrt{2}}\left(\frac{1}{\sqrt{2}} - \frac{1}{\sqrt{2}}i\right) = \frac{1}{2} - \frac{i}{2}</math></p> </div>  </div> <p>(ii)</p> <p>Kite</p> <p>(b)(i)</p> <div style="border: 1px dashed black; width: 100px; height: 100px; margin: 10px auto;"></div> <p>Circle centre (3,4) radius 5,  <math> z </math> = length of diameter = 10</p> <p>(ii)</p>  <p>Ellipse <math>\frac{(x-6)^2}{36} + \frac{(y-4)^2}{27} = 1</math></p> <p>Greatest argument is positive <math>y</math> axis ie <math>\arg(z) = \frac{\pi}{2}</math></p>	<p>2 marks correct method leading to correct solution                      1mark substantial progress towards the correct solution</p> <p>2 marks both correct answers                      1mark one correct answer</p> <p>2 marks both correct answers                      1mark one correct answer</p> <p>2 marks both correct answers                      1mark one correct answer</p>

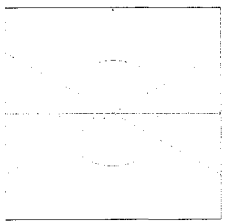
<p>c)</p> <p><math>w = \sqrt{2} - i\sqrt{2}</math></p> <p><math> w  = \sqrt{(\sqrt{2})^2 + (\sqrt{2})^2} = 2</math></p> <p><math>\arg(w) = \tan^{-1}\left(\frac{-\sqrt{2}}{\sqrt{2}}\right) = -\frac{\pi}{4}</math></p> <p><math>w = 2\left(\cos\left(-\frac{\pi}{4}\right) + i\sin\left(-\frac{\pi}{4}\right)\right)</math></p> <p>ii</p> <p><math>w^{22} = 2^{22}\left(\cos\left(-\frac{22\pi}{4}\right) + i\sin\left(-\frac{22\pi}{4}\right)\right)</math></p> <p><math>w^{22} = 2^{22}\left(\cos\left(\frac{\pi}{2}\right) + i\sin\left(\frac{\pi}{2}\right)\right) = i2^{22}</math></p> <p>d)(i),(ii)</p> <p><math>z^6 = -1</math></p> <p><math>z^6 + 1 = 0</math></p> <p><math>(z^3 + 1)(z^3 - z^2 + 1) = 0</math></p> <p><math>(z^2 + 1) = 0</math></p> <p><math>z = \pm i</math> and the roots below</p> <p><math>(z^4 - z^2 + 1) = 0</math></p> <p><math>z_1 = \text{cis}\left(\frac{\pi}{6}\right) = \frac{\sqrt{3}}{2} + i\frac{1}{2}</math></p> <p><math>z_2 = \text{cis}\left(\frac{5\pi}{6}\right) = -\frac{\sqrt{3}}{2} + i\frac{1}{2}</math></p> <p><math>z_3 = \text{cis}\left(\frac{7\pi}{6}\right) = -\frac{\sqrt{3}}{2} - i\frac{1}{2}</math></p> <p><math>z_4 = \text{cis}\left(\frac{11\pi}{6}\right) = \frac{\sqrt{3}}{2} - i\frac{1}{2}</math></p> 	<p>1mark one correct answer</p> <p>1mark correct solution</p> <p>2 marks correct method leading to correct solution                      1mark substantial progress towards the correct solution</p> <p>2 marks correct method leading to correct solution                      1mark substantial progress towards the correct solution</p> <p>1mark correct solution</p>
--	---

Question 15

a) i

$$PS = ePM$$

$$\sqrt{(x-2)^2 + y^2} = \sqrt{2} \sqrt{(x-1)^2 + (y-1)^2}$$

$$(x-2)^2 + y^2 = 2(x-1)^2$$

$$y^2 = 2(x-1)^2 - (x-2)^2$$

$$x^2 - y^2 = 2$$

$$\frac{x^2}{2} - \frac{y^2}{2} = 1$$

for asymptotes

$$\left(\frac{x}{\sqrt{2}} - \frac{y}{\sqrt{2}}\right)\left(\frac{x}{\sqrt{2}} + \frac{y}{\sqrt{2}}\right) = 0$$

$$\frac{x}{\sqrt{2}} = \frac{y}{\sqrt{2}}, \frac{x}{\sqrt{2}} = -\frac{y}{\sqrt{2}}$$

$$y = x, y = -x$$

$m_1 \times m_2 = -1 \therefore$  asymptotes at  $90^\circ$  and rectangular.

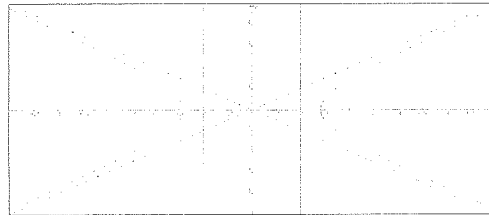

ii

$$P(\sqrt{2} \sec \theta, \sqrt{2} \tan \theta)$$

$$\frac{dy}{dx} = \frac{dy}{d\theta} \times \frac{d\theta}{dx} = \frac{\sqrt{2} \sec^2 \theta}{\sqrt{2} \sec \theta \tan \theta} = \frac{\sec \theta}{\tan \theta}$$

$$\text{gradient normal } m = -\frac{\tan \theta}{\sec \theta}$$

$$y - \sqrt{2} \tan \theta = -\frac{\tan \theta}{\sec \theta} (x - \sqrt{2} \sec \theta)$$

$$y \sec \theta + x \tan \theta = 2\sqrt{2} \tan \theta \sec \theta$$

(iii)

$$y = 0, x = 2\sqrt{2} \sec \theta$$

$$x = 0, y = 2\sqrt{2} \tan \theta$$

$$T = (X, Y) = (2\sqrt{2} \sec \theta, 2\sqrt{2} \tan \theta)$$

$$X^2 - Y^2 = (2\sqrt{2} \sec \theta)^2 - (2\sqrt{2} \tan \theta)^2 = 8(\sec^2 \theta - \tan^2 \theta)$$

$$X^2 - Y^2 = 8$$

3/4

1 mark correct solution

1 mark correct solution

1 mark correct graph

1 mark correct solution

2 marks correct method leading to correct solution  
1 mark substantial progress towards the correct solution

b(i)

$$C_1 \equiv x^2 + 3y^2 - 1, C_2 \equiv 4x^2 + y^2 - 1$$

$$C_1 = 0, \text{ then } x^2 + 3y^2 - 1 = 0 \text{ and if } C_2 = 0, \text{ then } 4x^2 + y^2 - 1 = 0$$

if  $P(x_1, y_1)$  is on  $C_1$  and  $C_2$  then

$$x_1^2 + 3y_1^2 - 1 = 0 \text{ and } 4x_1^2 + y_1^2 - 1 = 0$$

$$x^2 + 3y^2 - 1 + \lambda(4x^2 + y^2 - 1) = 0$$

$$x_1^2 + 3y_1^2 - 1 + \lambda(4x_1^2 + y_1^2 - 1) = 0$$

$$\therefore P \text{ lies on } x^2 + 3y^2 - 1 + \lambda(4x^2 + y^2 - 1) = 0$$

ii

$$x^2 + 3y^2 - 1 + \lambda(4x^2 + y^2 - 1) = 0$$

$$x^2(1+4\lambda) + y^2(3+\lambda) = 1 + \lambda$$

$$x^2 \times \frac{1+4\lambda}{1+\lambda} + y^2 \times \frac{3+\lambda}{1+\lambda} = 1$$

$$\frac{1+4\lambda}{1+\lambda} \times \frac{3+\lambda}{1+\lambda} > 0$$

$$(1+4\lambda)(3+\lambda) > 0$$

$$\lambda > -\frac{1}{4}$$

$$\lambda < -3$$

(c)

(i)

$$\text{let } P(x) = (x-\alpha)^n Q(x)$$

$$P'(x) = (x-\alpha)^n Q'(x) + n(x-\alpha)^{n-1} Q(x)$$

$$P'(x) = (x-\alpha)^{n-1} [(x-\alpha) Q'(x) + nQ(x)]$$

$$\therefore P'(\alpha) = 0$$

(ii)

$$P(x) = 18x^3 + 3x^2 - 28x + 12$$

$$P'(x) = 54x^2 + 6x - 28 = 0$$

$$2(3x-2)(9x+7) = 0$$

$$P\left(\frac{2}{3}\right) = 18\left(\frac{2}{3}\right)^3 + 3\left(\frac{2}{3}\right)^2 - 28\left(\frac{2}{3}\right) + 12 = 0$$

$$\left(\frac{2}{3}\right) \times \left(\frac{2}{3}\right) \times \beta = -\frac{12}{18}$$

$$\beta = -\frac{3}{2}$$

(d)

if  $\alpha$  is a root of  $2x^3 - x^2 + 3x + 5$

$$\text{then } 2\alpha^3 - \alpha^2 + 3\alpha + 5 = 0$$

$$\frac{2}{x^3} - \frac{1}{x^2} + \frac{3}{x} + 5 = 0 \text{ will have roots } \frac{1}{\alpha} \text{ etc}$$

$$\text{since } 2\alpha^3 - \alpha^2 + 3\alpha + 5 = 0.$$

$$\therefore P(x) = 2 - x + 3x^2 + 5x^3 \text{ is the desired polynomial.}$$

2 marks correct method leading to correct solution  
1 mark substantial progress towards the correct solution

2 marks correct method leading to correct solution  
1 mark substantial progress towards the correct solution

1 mark correct solution

2 marks correct method leading to correct solution  
1 mark substantial progress towards the correct solution

2 marks correct method leading to correct solution  
1 mark substantial progress towards the correct solution

Year 12	Mathematics Extension 2	Trial HSC Examination 2014
Question	Solutions and Marking Guidelines	
Outcome Addressed in this Question		
E6	combines the ideas of algebra and calculus to determine the important features of the graphs of a wide variety of functions	
E5	uses ideas and techniques from calculus to solve problems in mechanics involving resolution of forces, resisted motion and circular motion	
Part	Solutions	Marking Guidelines
(a) (i)		<p>Award 2 Correct graph</p> <p>Award 1 Substantial progress towards solution.</p>
(a) (ii)		<p>Award 2 Correct graph</p> <p>Award 1 Substantial progress towards solution.</p>

(a) (iii)		<p>Award 2 Correct graph</p> <p>Award 1 Substantial progress towards solution.</p>
(a) (iv)		<p>Award 2 Correct graph</p> <p>Award 1 Substantial progress towards solution.</p>

(b) (i)	$F = ma = m\ddot{x}$ Resistance has negative sign $\therefore m\ddot{x} = -(v + v^3)$ $\therefore \ddot{x} = -(v + v^3)$ since $m = 1$	<p>Award 1 Correct solution</p>
(b) (ii)	$\ddot{x} = v \frac{dv}{dx} = -(v + v^3)$ $\therefore \frac{dv}{dx} = -(1 + v^2)$ $\therefore \frac{dx}{dv} = -\frac{1}{1 + v^2}$ $\therefore \int dx = -\int \frac{1}{1 + v^2} dv$ $\therefore x = -\tan^{-1} v + c$ When $t = 0, v = Q, x = 0 \Rightarrow c = \tan^{-1} Q$ $\therefore x = -\tan^{-1} v + \tan^{-1} Q = \tan^{-1} Q - \tan^{-1} v$ $\therefore \tan x = \tan(\tan^{-1} Q - \tan^{-1} v)$ $= \frac{\tan(\tan^{-1} Q) - \tan(\tan^{-1} v)}{1 + \tan(\tan^{-1} Q) \tan(\tan^{-1} v)}$ $= \frac{Q - v}{1 + Qv}$ $\therefore x = \tan^{-1} \left( \frac{Q - v}{1 + Qv} \right)$	<p>Award 2 Correct solution</p> <p>Award 1 Substantial progress towards solution.</p>
(b) (iii)	$\ddot{x} = \frac{dv}{dt} = -(v + v^3)$ $\therefore \frac{dt}{dv} = \frac{-1}{v + v^3} = \frac{-1}{v(1 + v^2)} = -\left( \frac{1}{v} - \frac{v}{1 + v^2} \right)$ $\therefore \int dt = -\int \left( \frac{1}{v} - \frac{v}{1 + v^2} \right) dv$ $\therefore t = -\ln v + \frac{1}{2} \ln(1 + v^2) + c$ When $t = 0, v = Q \Rightarrow c = \ln Q - \frac{1}{2} \ln(1 + Q^2)$ $\therefore t = -\ln v + \frac{1}{2} \ln(1 + v^2) + \ln Q - \frac{1}{2} \ln(1 + Q^2)$ $= \frac{1}{2} \left[ -2 \ln v + \ln(1 + v^2) + 2 \ln Q - \ln(1 + Q^2) \right]$ $= \frac{1}{2} \ln \left[ \frac{Q^2(1 + v^2)}{v^2(1 + Q^2)} \right]$	<p>Award 2 Correct solution</p> <p>Award 1 Substantial progress towards solution.</p>

(b) (iv)	$2t = \ln \left[ \frac{Q^2(1 + v^2)}{v^2(1 + Q^2)} \right]$ $\therefore e^{2t} = \frac{Q^2(1 + v^2)}{v^2(1 + Q^2)}$ $\therefore e^{2t} v^2(1 + Q^2) = Q^2(1 + v^2)$ $\therefore v^2(e^{2t}(1 + Q^2) - Q^2) = Q^2$ $\therefore v^2 = \frac{Q^2}{e^{2t}(1 + Q^2) - Q^2}$	<p>Award 2 Correct solution</p> <p>Award 1 Substantial progress towards solution.</p>
----------	--	---

Year 12 Question No.16	Extension 2 Mathematics Solutions and Marking Guidelines Outcomes Addressed in this Question	TRIAL HSC 2014
E2 - chooses appropriate strategies to construct arguments and proofs in both concrete and abstract settings E9 - communicates abstract ideas and relationships using appropriate notation and logical argument		
Outcome	Solutions	Marking Guidelines
E2	<p>(a)</p> <p><math>PQ = AP + BQ</math> (tangents drawn from <math>P</math> are equal, and tangents drawn from <math>Q</math> are equal)</p> <p>Now, perimeter of <math>\triangle CPQ = CP + CQ + PQ</math>  <math>= CP + CQ + AP + BQ</math> (<math>PQ = AP + BQ</math>)  <math>= CP + AP + CQ + BQ</math>  <math>= CA + CB</math>  <u>Which is constant and independent of <math>PQ</math>.</u></p>	<p><u>3 marks:</u> correct solution</p> <p><u>2 marks:</u> substantially correct solution</p> <p><u>1 mark:</u> meaningful progress towards correct solution</p>
E2, E9	<p>(b)(i) <math>f(x) = \frac{(n+1+x)^{n+1}}{(n+x)^n}</math></p> $f'(x) = \frac{(n+1)(n+1+x)^n (n+x)^n - n(n+x)^{n-1} (n+1+x)^{n+1}}{(n+x)^{2n}}$ $= \frac{(n+1+x)^n (n+x)^{n-1} [(n+1)(n+x) - n(n+1+x)]}{(n+x)^{2n}}$ $= \frac{(n+1+x)^n (n+x)^{n-1} [x]}{(n+x)^{2n}}$ $= \frac{(n+1+x)^n x}{(n+x)^{n+1}} > 0 \text{ for } x > 0, \text{ as } n \geq 1$ <p><math>\therefore f(x)</math> is an increasing function</p>	<p><u>2 marks:</u> correct solution</p> <p><u>1 mark:</u> substantially correct solution</p>

E2, E9	<p>(b)(ii) <math>f(x) &gt; f(0)</math> (as <math>f(x)</math> is an increasing function)</p> $\frac{(n+1+x)^{n+1}}{(n+x)^n} > \frac{(n+1)^{n+1}}{(n)^n} \left( \div \frac{(n+1)^{n+1}}{(n+x)^2} \right)$ $\frac{(n+1+x)^{n+1}}{(n+1)^{n+1}} > \frac{(n+x)^n}{(n)^n}$ $\left(1 + \frac{x}{n+1}\right)^{n+1} > \left(1 + \frac{x}{n}\right)^n$	<p><u>2 marks:</u> correct solution</p> <p><u>1 mark:</u> substantially correct solution</p> <p><i>NB: this solution requires the use of part (i) to obtain marks... (hence...)</i></p>
E2, E9	<p>(b)(iii) <math>\left(1 + \frac{x}{n+1}\right)^{n+1} &gt; \left(1 + \frac{x}{n}\right)^n</math></p> $\left(1 + \frac{1}{n+1}\right)^{n+1} > \left(1 + \frac{1}{n}\right)^n \quad (\text{sub } x=1)$ $\left(\frac{n+1+1}{n+1}\right)^{n+1} > \left(\frac{n+1}{n}\right)^n$ $(n+2)^{n+1} n^n > (n+1)^n (n+1)^{n+1}$ $(n+2)^{n+1} n^n > (n+1)^{2n+1}$	<p><u>2 marks:</u> correct solution</p> <p><u>1 mark:</u> substantially correct solution</p>
E2, E9	<p>(c)(i) <math>\int_1^n \ln x \, dx \approx \frac{1}{2} [\ln 1 + \ln n + 2(\ln 2 + \ln 3 + \ln 4 + \dots + \ln(n-1))]</math></p> $= \frac{1}{2} [\ln 1 + \ln n + 2 \ln(2.3.4 \dots (n-1))]$ $= \frac{1}{2} \ln n + \ln(2.3.4 \dots (n-1))$ $= \frac{1}{2} \ln n + \ln(n-1)!$ $= \frac{1}{2} \ln n - \ln n + \ln n + \ln(n-1)!$ $= \ln(n)! - \frac{1}{2} \ln n$	<p><u>2 marks:</u> correct solution</p> <p><i>NB: n function values means (n-1) strips (applications)</i></p> <p><u>1 mark:</u> substantially correct solution</p>
	<p>(c)(ii) <math>\frac{d}{dx}(x \ln x - x) = 1 \cdot \ln x + \frac{1}{x} \cdot x - 1 = \ln x</math></p> $\int_1^n \ln x \, dx = [x \ln x - x]_1^n$ $= [n \ln n - n] - [1 \ln 1 - 1]$ $= n \ln n - n + 1$	<p><u>2 marks:</u> correct solution</p> <p><u>1 mark:</u> substantially correct solution</p>
	<p>(iii) Trapeziums lie under the curve, so (i) is an underestimate.</p> $\text{i.e. } \ln n! - \frac{1}{2} \ln n < n \ln n - n + 1$ $\ln n! < n \ln n + \frac{1}{2} \ln n - n + 1$ $\ln n! < \left(n + \frac{1}{2}\right) \ln n - n + 1$	<p><u>2 marks:</u> correct solution</p> <p><u>1 mark:</u> substantially correct solution</p>