

YEAR 12 TRIAL HSC EXAMINATION

2003

MATHEMATICS

EXTENSION 2

*Time Allowed: 3 hours
(plus 5 minutes reading time)*

INSTRUCTIONS TO CANDIDATES:

- ALL questions should be attempted.
- All questions are of equal value (15 marks).
- Part marks are shown on the right hand side.
- Marks may not be awarded for careless or badly arranged work.
- Standard integrals are provided on the back page.
- Board-approved calculators may be used.
- If you use a second booklet for a question, place it inside the first.

QUESTION 1. (START A NEW BOOKLET)

- (a) Find $\int \frac{dx}{x \log x}$ 2
- (b) Find $\int \frac{dx}{x^2 + 6x + 10}$ 2
- (c) Use the substitution $u = \sqrt{1-x}$ to evaluate $\int_0^1 x^2 \sqrt{1-x} \, dx$ 3
- (d) Use integration by parts to evaluate $\int_0^1 \sin^{-1} x \, dx$ 3
- (e) (i) Find real numbers a , b and c such that $\frac{5x^2 - 5x + 14}{(x^2 + 4)(x - 2)} = \frac{ax + b}{x^2 + 4} + \frac{c}{x - 2}$ 2
- (ii) Find $\int \frac{5x^2 - 5x + 14}{(x^2 + 4)(x - 2)} \, dx$ 3

QUESTION 2. (START A NEW BOOKLET)

- (a) Each of the following statements is either true or false. Write TRUE or FALSE for each statement and give brief reasons for your answers. (You are NOT required to evaluate the integrals.)

(i) $\int_0^1 e^{\frac{1}{2}x^2} dx = 0$ 1

(ii) $\int_{\frac{\pi}{4}}^{\frac{\pi}{2}} \tan^2 x dx = 0$ 1

(iii) $\int_0^{\pi} \cos^3 x dx > 0$ 1

(iv) $\int_0^1 \frac{dx}{\sqrt{1+x^2}} > \int_0^1 \frac{dx}{\sqrt{1+x^4}}$ 1

- (b) Consider the polynomial $P(x) = 8x^4 - 8x^2 - x + 1$. You are given that $P(x) = (x-1)Q(x)$ where $Q(x)$ is a cubic polynomial. 3

(i) Find $Q(x)$

(ii) If the equation $Q(x) = 0$ has one rational root then find the four solutions to the equation $P(x) = 0$

- (c) (i) Solve the equation $\cos 4\theta = \cos \theta$ giving the general solution. 8

(ii) Show that $\cos 4\theta = 8\cos^4 \theta - 8\cos^2 \theta + 1$

(iii) Show that the equation $\cos 4\theta = \cos \theta$ can be expressed in the form $8x^4 - 8x^2 - x + 1 = 0$ where $x = \cos \theta$.

(iv) Hence using part (b)(ii) find the exact value of:

(α) $\cos \frac{2\pi}{5}$

(β) $\cos \frac{\pi}{5}$

QUESTION 3. (START A NEW BOOKLET)

(a)

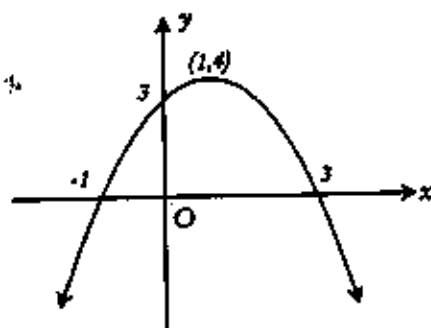

Let $f(x) = -(x-3)(x+1)$. In the diagram above, the graph of $y = f(x)$ is drawn. On separate diagrams, and without the use of calculus, sketch the following graphs. Indicate clearly any asymptotes, any intercepts with the coordinate axes, and any other significant features. Each diagram should take about ten lines.

- (i) $y = |f(x)|$ 2
- (ii) $y = \frac{1}{f(x)}$ 2
- (iii) $y = e^{f(x)}$ 2
- (iv) $y^2 = f(x)$ 2

(b)

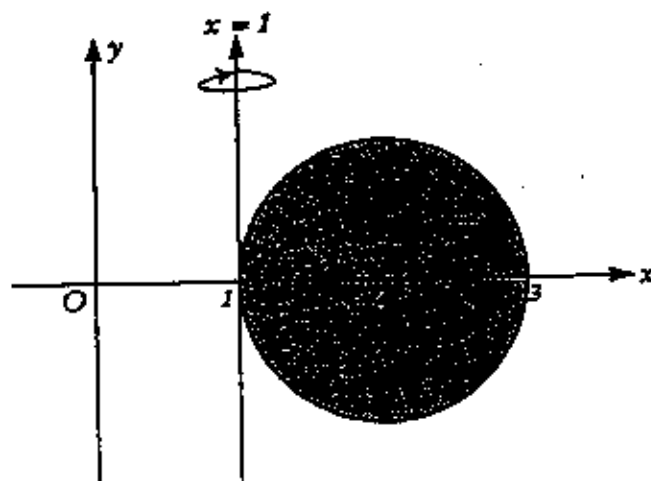

In the diagram above, the circle $(x-2)^2 + y^2 = 1$ is drawn. The region bounded by the circle is rotated about the line $x = 1$.

- (i) Use the method of cylindrical shells to show that the volume of the solid so formed is given by 3

$$V = 4\pi \int_1^3 (x-1)\sqrt{1-(x-2)^2} dx$$

- (ii) By using the substitution $x-2 = \sin \theta$, or otherwise, evaluate the integral in part (i) to find the volume of the solid. 4

QUESTION 4. (START A NEW BOOKLET)

(a) (i) Factorise the cubic polynomial $z^3 + 8$

5

 $\alpha)$ over the real field of numbers $\beta)$ over the complex field of numbersLet w be one of the complex roots of the equation $z^3 + 8 = 0$ (ii) Show that $w^2 = 2w - 4$ (iii) Hence simplify $(2w - 4)^6$

(b) The diagram shows the point A at a height h vertically above the point O . It also shows the point B which is positioned at a horizontal distance d from O . A projectile is fired from A directly at point B with a velocity V . At the same instant a projectile is fired from point B directly at point A with the same velocity V .

10

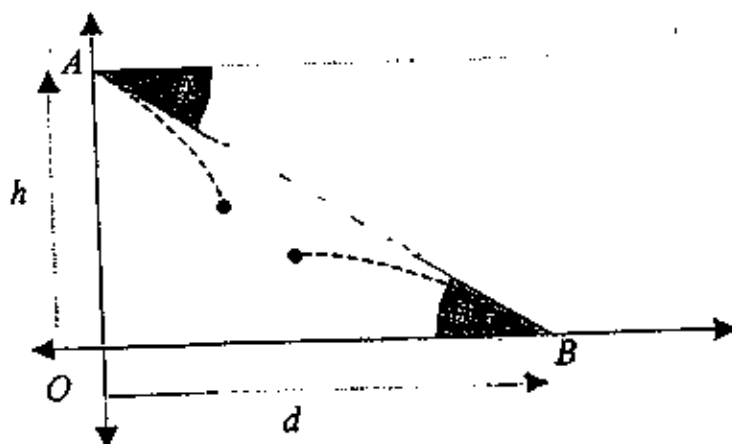
Let θ be the angle between the horizontal at A and the angle of projection.

(i) Show carefully that the equations of motion of the two projectiles are given by

$$x_A = Vt \cos \theta$$

$$x_B = d - Vt \cos \theta$$

$$y_A = h - Vt \sin \theta - \frac{gt^2}{2}$$

$$y_B = Vt \sin \theta - \frac{gt^2}{2}$$

(ii) Show that the two particles will always meet.

(iii) Show that the height, H , at which they meet is given by

$$H = \frac{h}{2} - \frac{g(h^2 + d^2)}{8V^2}$$

(iv) Find the range of values of V such that the two projectiles meet above the x -axis.

QUESTION 5. (START A NEW BOOKLET)

(a) The equation $x^3 + 2x^2 + bx - 16 = 0$ has roots α , β and γ such that $\alpha\beta = 4$

6

(i) Show that $b = -20$

(ii) Find the cubic equation with roots given by α^2 , β^2 and γ^2

(iii) Hence find the value of $\alpha^3 + \beta^3 + \gamma^3$

(b) Consider the roots to the equation $z^n - 1 = 0$. These roots are plotted on an Argand diagram. The points represented by these roots are joined to form a regular n -sided polygon.

9

(i) Show that the area of this polygon is given by $A_n = \frac{n}{2} \sin \frac{2\pi}{n}$

(ii) Show that the perimeter of the polygon is given by $P_n = 2n \sin \frac{\pi}{n}$

(iii) Show that $P_n > 2A_n$ for all positive integers n .

(iv) Show that the $\lim_{n \rightarrow \infty} A_n = \pi$ using the result that $\lim_{h \rightarrow 0} \frac{\sin h}{h} = 1$ and substituting an appropriate expression for n .

(v) Find the $\lim_{n \rightarrow \infty} P_n$

QUESTION 6. (START A NEW BOOKLET)

- (a) The semi-ellipse given by $\frac{x^2}{9} + \frac{(y-2)^2}{4} = 1$ where $0 \leq y \leq 2$ is drawn below:

6

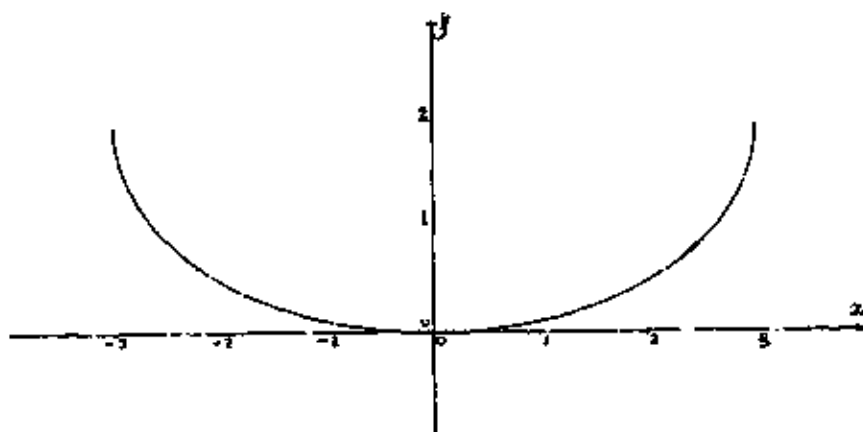

The point $P(r, h)$ lies on the ellipse where $r > 0$ and $0 < h < 2$. The tangent at P makes an angle α with the positive direction of the x -axis.

(i) Show that $\tan \alpha = \frac{4r}{9(2-h)}$

(ii) Hence, show that $\tan \alpha = \frac{2\sqrt{4-(2-h)^2}}{3(2-h)}$

- (iii) Show that the acute angle between the normal at the point P and the vertical line $x = r$ is equal to the angle between the tangent at P and the positive direction of the x -axis.

QUESTION 6. (Continued)

- (b) The semi-ellipse in part (a) is rotated about the y -axis to form a solid of revolution. A particle of unit mass slides smoothly in a horizontal circle on the inner surface of the solid so that it passes through the point P . The particle moves with a constant linear speed v .

9

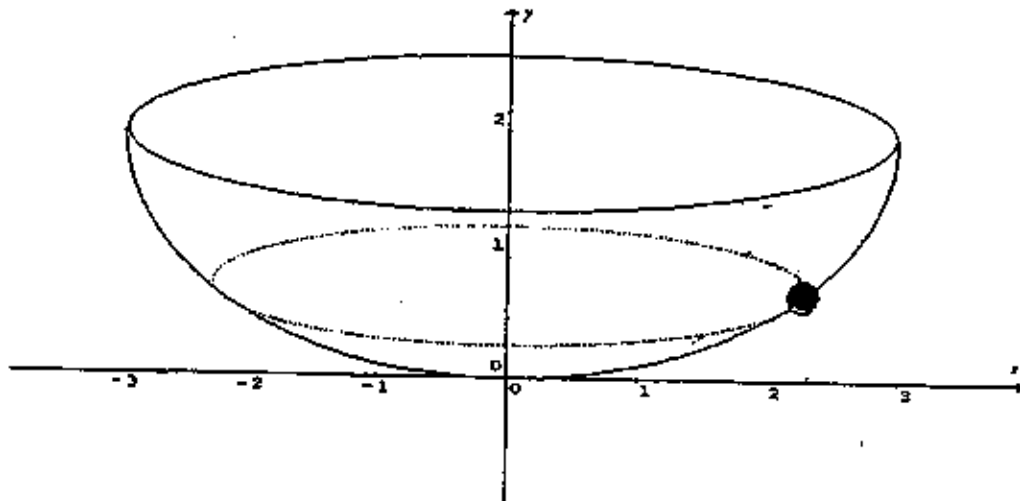

- (i) Draw a force diagram showing the forces acting on the particle at P .
- (ii) By resolving these forces horizontally and vertically show that
- $$v^2 = \frac{g[4 - (2 - h)^2]}{2 - h}$$
- (iii) If $h = 1$ then find the normal reaction of the surface of the solid on the particle.
- (iv) If the normal reaction is equal to $\sqrt{2}$ times the weight of the particle, then find the height h of the particle.

QUESTION 7. (START A NEW BOOKLET)

(a) (i) Show that $\frac{d}{dx}(\log_e(\sec x + \tan x)) = \sec x$ 1

(ii) Hence or otherwise show that $\int_0^{\frac{\pi}{4}} \sec x \, dx = \log_e(\sqrt{2} + 1)$ 2

(iii) Let $I_n = \int_0^{\frac{\pi}{4}} \sec^n x \, dx$. Use integration by parts to show that for $n \geq 2$

$$I_n = \frac{1}{n-1} \left((\sqrt{2})^{n-2} + (n-2)I_{n-2} \right)$$
 3

(iv) Hence find I_3 1

(b)

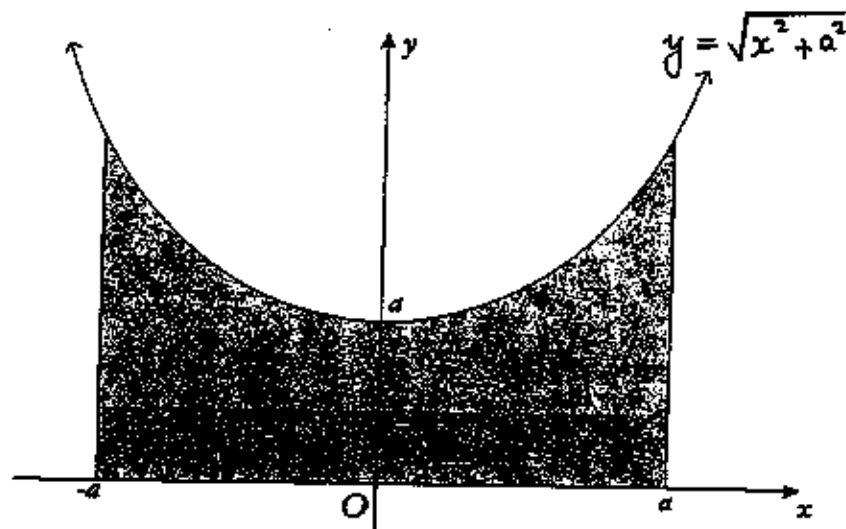

In the diagram above, the shaded area R is bounded by the upper branch of the hyperbola $y = \sqrt{x^2 + a^2}$, the lines $x = -a$ and $x = a$, and the x -axis, where a is positive. Show that the area of this region is given by $a^2(\sqrt{2} + \log_e(\sqrt{2} + 1))$. You may use the results of part (a). 4

QUESTION 7. (Continued)

(c)

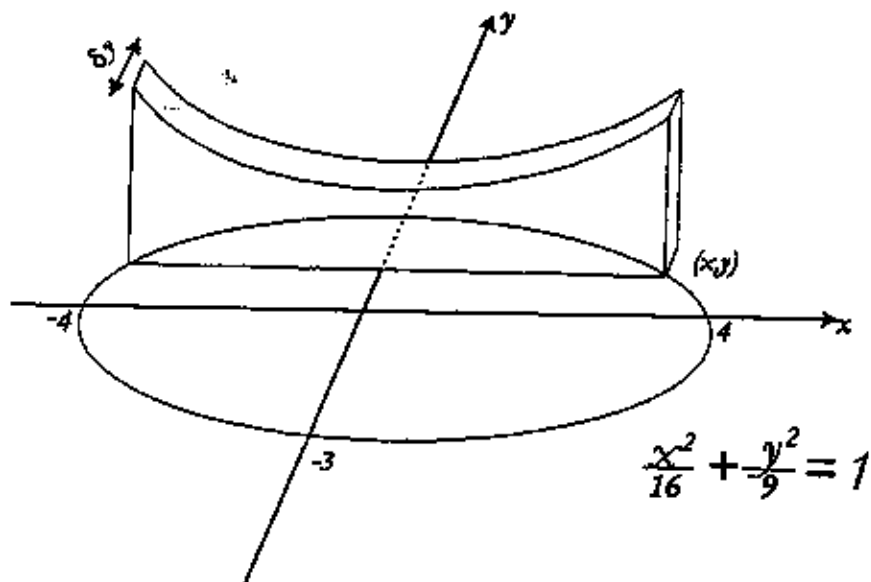

In the diagram above, a solid is constructed with base the ellipse $\frac{x^2}{16} + \frac{y^2}{9} = 1$.

Each cross-section perpendicular to the y -axis is a plane figure that is similar to the region R described in part (b). Find the volume of this solid.

4

QUESTION 8. (START A NEW BOOKLET)

- (a) The region R , bounded by $0 \leq x \leq 2$, $0 \leq y \leq 4x^2 - x^4$ is rotated about the y -axis. The solid so formed is sliced by planes perpendicular to the y -axis. Express the areas of the cross-sections so formed as a function of y , the distance of the plane from the origin. Use this result to calculate the volume of the solid.

8

- (b) (i) Show that the area bounded by the parabola $x^2 = 4ay$ and the latus rectum, $y = a$, is equal to $\frac{8a^2}{3}$

2

- (ii) A particular solid has a triangular base with side lengths all 6 metres. Cross-sections taken parallel to one side of the base are parabolas. Each parabolic cross-section is such that it has its latus rectum lying in the base of the solid.

Using part (b)(i) find the volume of the solid.

5

