

STUDENT NAME: _____

STUDENT NUMBER: _____



THE HILLS GRAMMAR SCHOOL

TRIAL HIGHER SCHOOL CERTIFICATE EXAMINATION

2008

GENERAL MATHEMATICS

General Instructions

- Reading time: 5 minutes
- Working time: 2 ½ hours
- Write using blue or black pen
- Approved calculators may be used
- A formula sheet is provided at the back of this paper

Total Marks 100

Section I

22 marks

- Attempt questions 1-22
- 1 mark each

Allow 30 minutes for this section

Section II

78 marks

- Attempt questions 23-28
- 13 marks each

Allow about 2 hours for this section

Section I

22 marks

Attempt Questions 1-22

Allow about 30 minutes for this section.

Use the multiple – choice answer sheet.

Select the alternative A, B, C or D that best answers the question.

1. Simplify $8x^5 - 2x^5$

- A. $6x^5$
- B. 4
- C. 6
- D. $6x$

2. The weights (in kg) of a sample of 8 newborn babies are shown:

2.75, 6.00, 3.75, 4.35, 4.15, 3.25, 2.90, 3.15

Find the mean of this sample?

- A. 1.06
- B. 3.79
- C. 0.99
- D. 3.25

3. In the triangle below, an expression for x is:

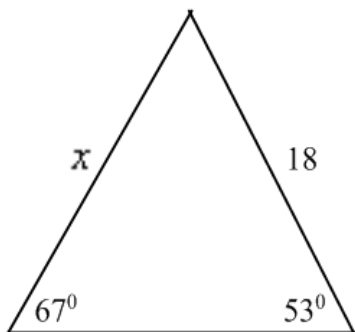

- A. $x = \frac{18 \sin 53^\circ}{\sin 67^\circ}$
- B. $x = \frac{\sin 53^\circ}{18 \sin 67^\circ}$
- C. $x = \frac{18 \sin 67^\circ}{\sin 53^\circ}$
- D. $x = \frac{\sin 67^\circ}{18 \sin 53^\circ}$

4. Makoua and Macapa are two towns on the equator.

The longitude of Makoua is 16°E and the longitude of Macapa is 52°W

Find the angular distance between these two towns?

- A. 68°
- B. 36°
- C. 55°
- D. 0°

5. What is the equation for this straight line?

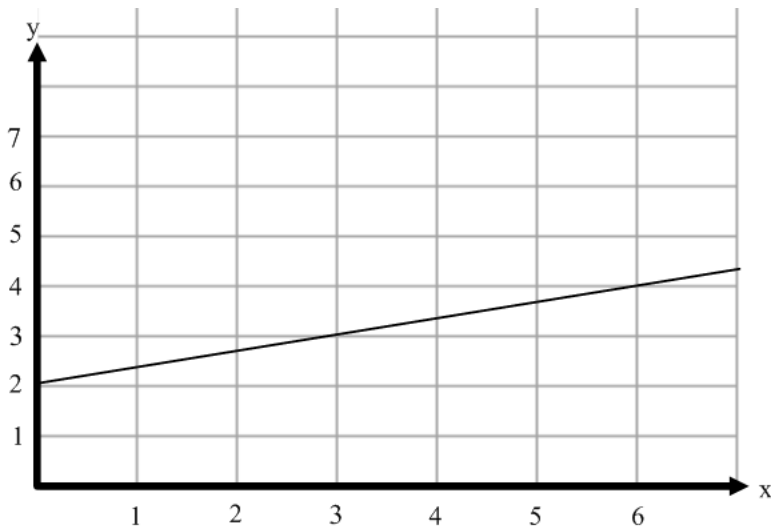

- A. $y = 3x + 2$
- B. $y = \frac{x}{3} + 2$
- C. $y = 3x + 5$
- D. $y = 2x - 2$

6. A competition has been arranged so that four teams A, B, C and D will play each other twice in the season. How many games must be played in this competition?

- A. 6
- B. 8
- C. 12
- D. 18

7. Which of the graphs best represents negatively skewed data with the largest standard deviation?

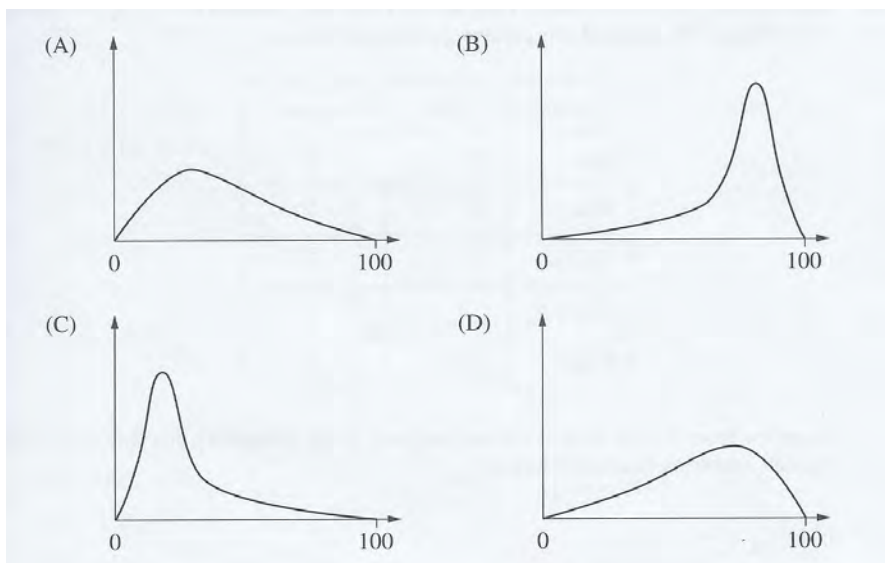

8. What is the length of AC correct to 1 decimal place?

- A. 4.8cm
- B. 5.2cm
- C. 6.6cm
- D. 7.1cm

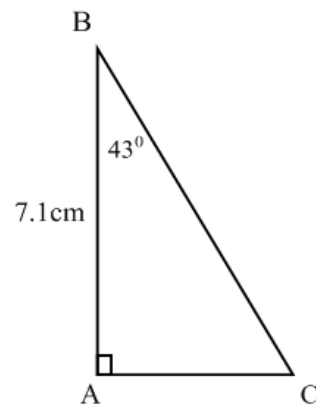

9. 2000 teenagers were surveyed about their mobile phone usage over a month. The box and whisker plot shows the number of text messages they received in a month.

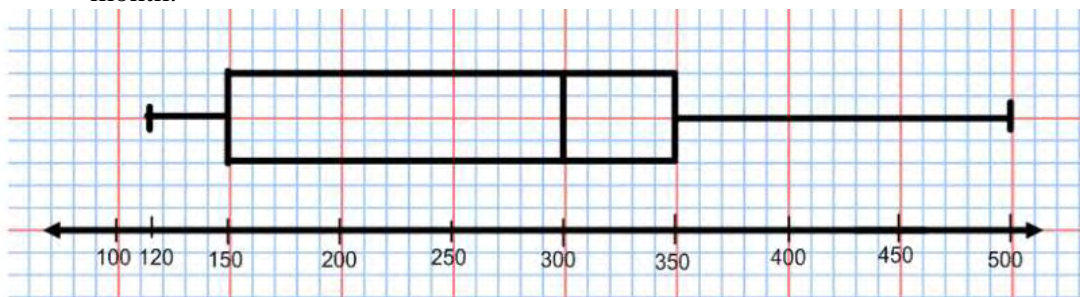

How many teenagers received between 300 and 350 text message a month?

- A. 250
- B. 500
- C. 380
- D. 200

10. Fifty tickets are sold in a raffle. There are two prizes. Michael buys three tickets. Which expression gives the probability that Michael wins both prizes?

- A. $\frac{3}{50} + \frac{2}{50}$
- B. $\frac{3}{50} + \frac{2}{49}$
- C. $\frac{3}{50} \times \frac{2}{50}$
- D. $\frac{3}{50} \times \frac{2}{49}$

11. It takes 3 hours to fly from Wellington, New Zealand to Sydney, Australia. Given that Wellington time is GMT +12 and Sydney is GMT +10. Find the time of arrival in Sydney when the flight leaves Wellington at 16:20.

A. 14:20
B. 17:20
C. 19:20
D. 21:20

12. Water covers about 70% of the Earth's surface. Assuming the radius of the Earth is 6400km, Calculate the area of the Earth's surface that is occupied by land in square kilometres.

A. 1920
B. 4480
C. 3.6×10^8
D. 1.5×10^8



13. There are 12 boys and 12 seats on a roller coaster. All boys wish to sit on the front two seats of the roller coaster. How many different combinations of boys are possible to sit at the front of the roller coaster?

A. 144
B. 132
C. 66
D. 72

14. A game involves 2 unbiased coins being thrown. A player wins \$2 if both heads come up and loses \$0.80 if one head comes up. It costs \$0.50 to play the game. What is the financial expectation for this game?

A. Win \$0.10
B. Loss \$0.05
C. Loss \$0.40
D. Loss \$0.30

15. At a childcare centre the number of staff required for the number of children in attendance is described by the following graph.

If the number of children at the centre dropped from 45 to 20, how many staff would no longer be required?

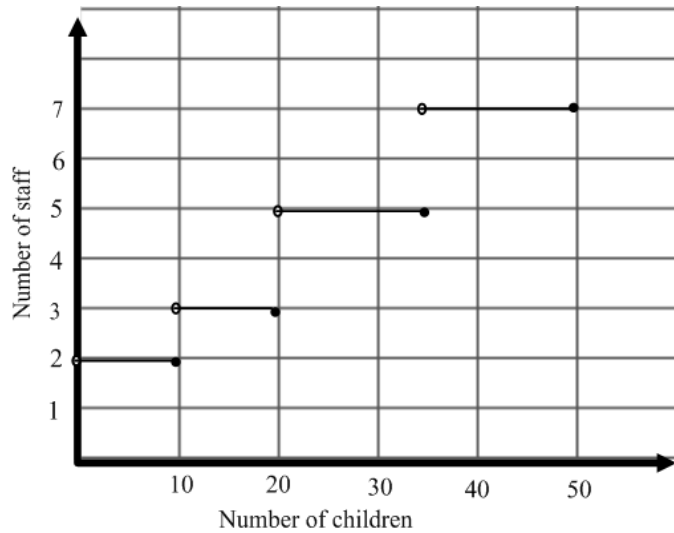

- A. 1
- B. 2
- C. 3
- D. 4

16. Which one of the following equations is equivalent to the equation:

$$y = bx + 2ax^2$$

- A. $a = y - bx - 2x^2$
- B. $a = \frac{b - y}{2x}$
- C. $a = \frac{y - bx}{2x^2}$
- D. $a = \frac{bx - y}{2x^2}$

17. In a factory every sixth toy is inspected. What type of sampling is this?

- A. census
- B. stratified
- C. random
- D. systematic

18. Find the z-score for a student with a result of 78%, when the mean is 68% and standard deviation is 8.

- A. 1.25
- B. 2.00
- C. -1.25
- D. -2.00

19. Find the volume of the triangular prism.

- A. 560 cm^3
- B. 168 cm^3
- C. 280 cm^3
- D. 336 cm^3

NOT TO SCALE

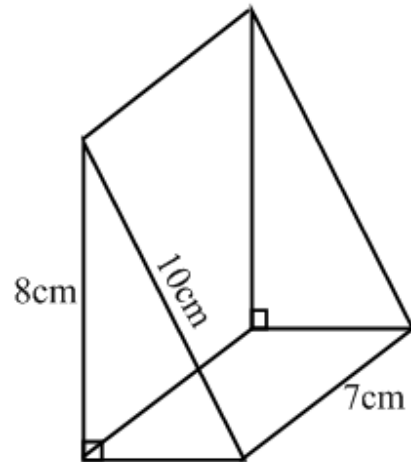

20. In a normally distributed set of scores, the mean is 16 and the standard deviation is 2. Approximately what percentage of the scores will lie between 14 and 20?

- A. 34%
- B. 47.5%
- C. 68%
- D. 81.5%

21. Which graph shows a high negative correlation?

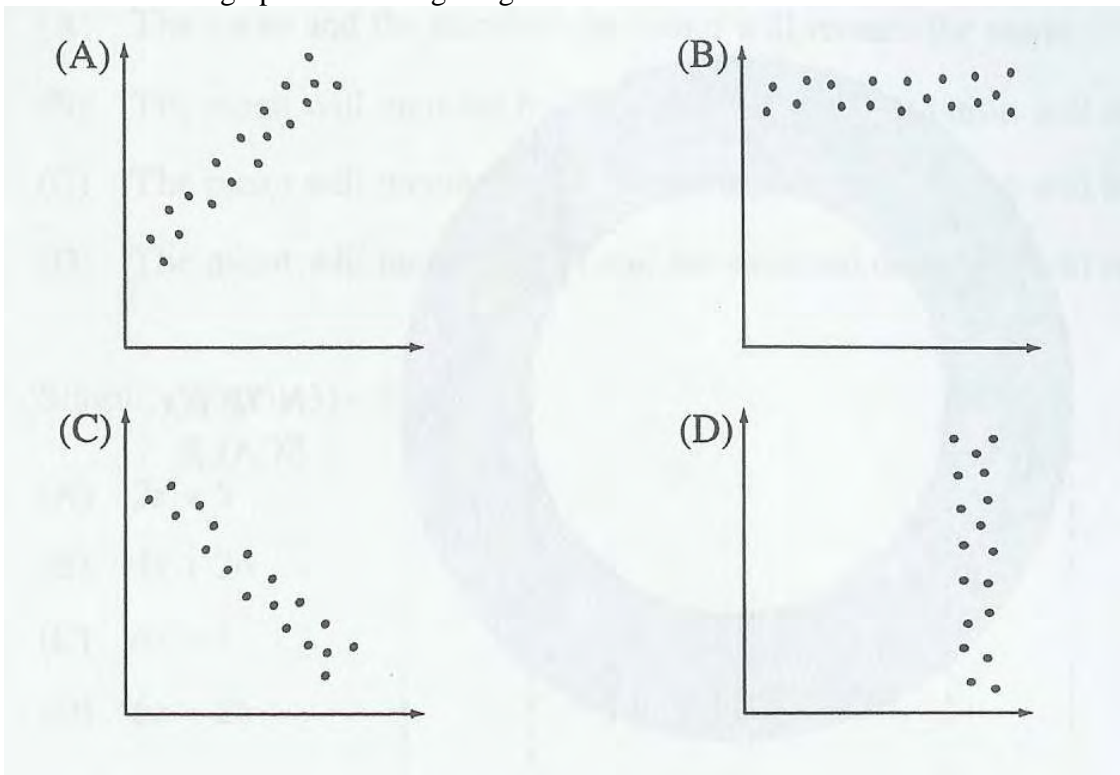

22. The results from a spelling test are displayed in a stem and leaf plot.

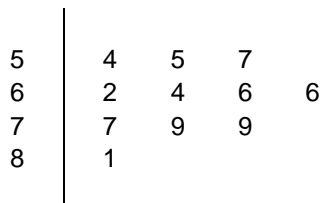

Patricia was absent on the day that the test was conducted and her result of 78 needs to be added to the data displayed above. Which statistical measure is most affected by the addition of Patricia's results to the data?

- A. Mean
- B. Mode
- C. Median
- D. Range

End of Section I

Section II

78 marks

Attempt Questions 23-28

Allow about 2 hours for this section

All necessary working should be shown in every question.

START A NEW PAGE

Question 23 (13 marks)

Marks

a)

- i. Find the area of this ellipse to the nearest square centimetre.

1

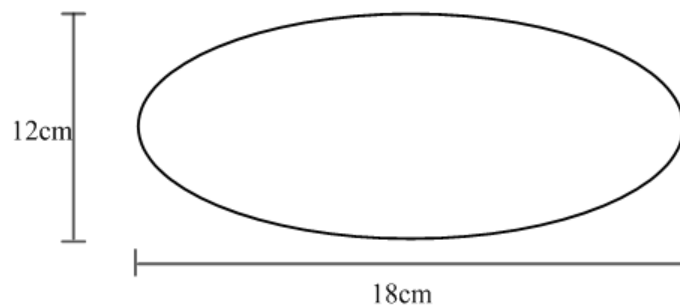

- ii. A private investigation company uses this ellipse, with a black circle inside, as shown, as the basis for their new logo. Find the area of the unshaded part of the logo to the nearest square centimetre.

2

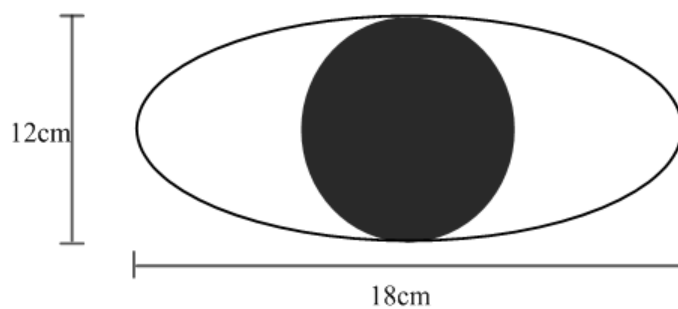

Question 23 (continued)

Marks

- b) A compass radial survey of parkland was conducted.
The notebook entries are record below.

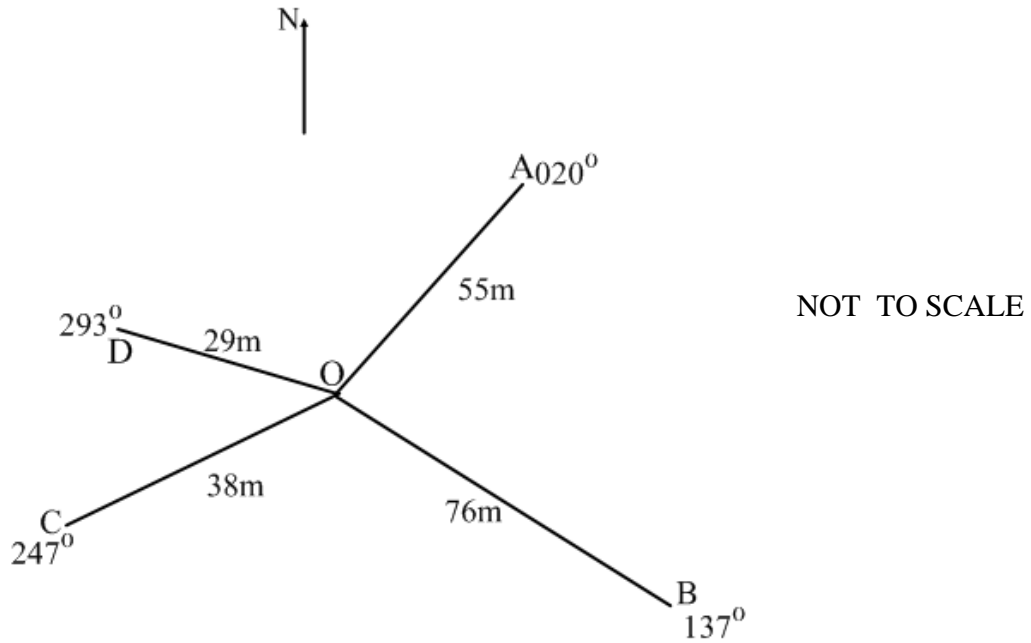

- i. Show that $\angle DOA = 87^\circ$ **1**

- ii. Using Cosine Rule, calculate the size of AD to 1 decimal place. **2**

- iii. Find the area of triangular parkland DOC correct to the nearest square metre. **2**

Question 23 (continued)**Marks**

- c) Twenty passengers were randomly chosen at two railway stations. They were asked what length of time (in minutes) they had been waiting at the station for the train to arrive.

The ordered double stem-and-leaf plot below records their responses.

Station X						0	Station Y							
7	6	6	3	□	1	1	3	6	7	9				
	5	5	5	4	1	2	0	0	1	3	3	3		
9	9	9	9	2	0	3	1	2						

- i. Write down the range, in minutes, of the waiting time for the Station Y sample. **1**
- ii. One entry (shown by the box) is missing from Station X.
Give a possible number of minutes that this passenger had been at the station. **2**
- iii. Calculate the mean and the standard deviation of the waiting time for the Station Y sample, correct to 1 decimal place. **2**

End of Question 23

START A NEW PAGE
Question 24 (13 marks)

Marks

- a) The weights (kg) of a random sample of 50 children were recorded at a particular kindergarten in 1995. Ten Years later the weights of another random sample of 50 children were recorded from the same kindergarten. The data for the two samples is displayed in the box and whisker plot below.

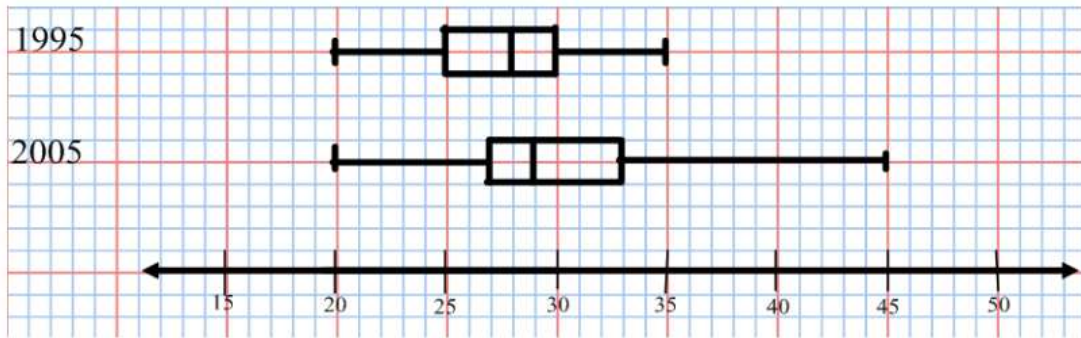

- i. What was the weight of the heaviest child? **1**
- ii. What was the median weight of the sample taken in 1995? **1**
- iii. What was the interquartile range of the sample taken in 2005? **1**
- iv. What percentage of the children in the sample taken in 1995 weigh more than 25kg? **1**
- v. Compare and contrast the data for 1995 and 2005 by observing the shape and skewness of the distribution together with the location and spread. **3**

Question 24 (continued)

Marks

- b) Patrick travels from Perth (31° S , 115° E) to Lisbon (39° N , 10° W) via Beijing (39° N , 115° E)

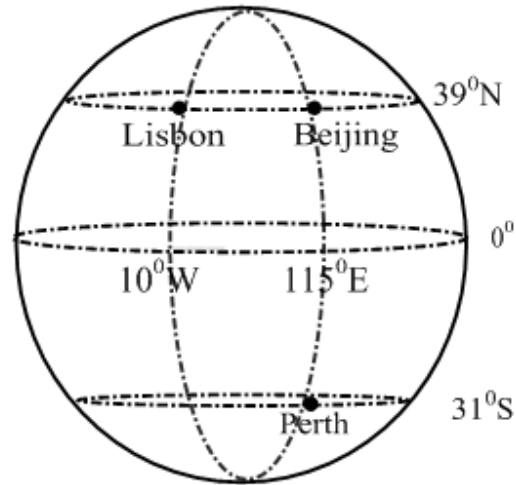

- | | | |
|------|--|----------|
| i. | Show that the distance from Perth to Beijing is approximately 4200 nautical miles. | 2 |
| ii. | Patrick travels at an average speed of 240 knots.
Calculate the time taken to travel from Perth to Beijing. | 1 |
| iii. | If it is 1 pm on Tuesday in Perth, what time is it in Beijing ? | 1 |
| iv. | The journey from Perth to Lisbon via Beijing takes 40 hours
If Patrick leaves Perth at 1 pm on Tuesday 15 th April,
What day and time will he arrive in Lisbon? | 2 |

End of Question 24

START A NEW PAGE
Question 25 (13 marks)

Marks

a) In the Trial HSC examinations Rima's results were as follows:

Subject	Rima's Results	Course Average	Course Standard Deviation
Physics	65	72	3.5
Mathematics	65	72	11

- i. Convert Rima's Physics mark to a z-score **1**
- ii. Compare Rima's performance in both Physics and Mathematics. Which performance is better? Use statistics to justify your answer. **2**
- iii. Rima has collected the results of ten students who study both Physics and Mathematics and has displayed the results in the scatter graph below. Rima is preparing to fit a median regression line to the data.

STEP 1: Divided the data into three sections as shown.

STEP 2: Find the coordinates of the medians for each of the three sections, Coordinate B (76, 74) and C (63.5, 63.5) have already been found.

Find the coordinates for A the median of the first section. **1**

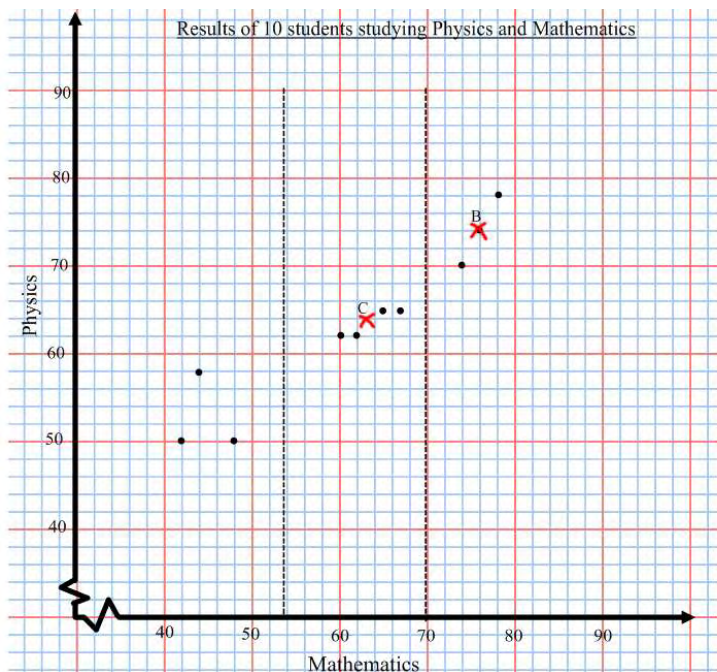

- iv. Describe the final steps Rima must take to complete the median regression line. **2**

Question 25 (continued)**Marks**

- v. The equation of the median regression line for the data may be approximated by **1**

$$\text{Physics} = \frac{3}{4} \text{Mathematics} + 17$$

Using this equation predict the mathematics results for a student who achieved a Physics result of 41.

- vi. Rima calculated a correlation coefficient of -1.2 for the data (part iii). **2**
Give TWO reasons why Rima must be incorrect.

- b) The diagram shows the vertical cross section of Merricks River

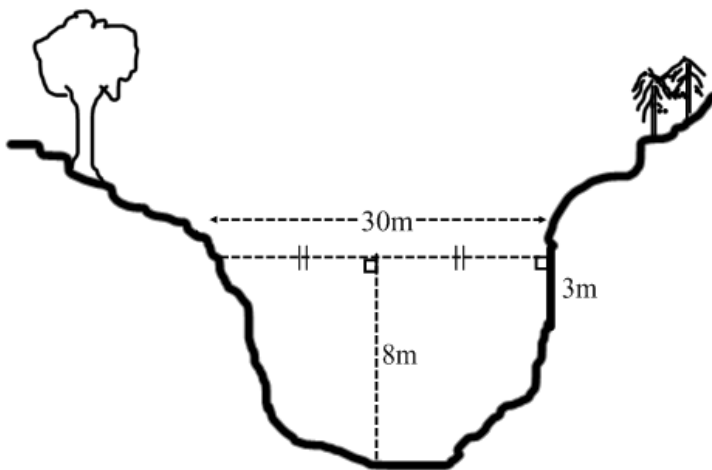

NOT TO SCALE

- i. Use Simpsons Rule to find the area of the cross section to the nearest metre. **2**
- ii. If the water in Merricks River is flowing at a steady rate of 12 metres per minute, How many litres of water flows past this section each hour? **2**

End of Question 25

START A NEW PAGE

Question 26 (13 marks)

Marks

- a) In a test, there are 4 questions to be answered true (T) or False (F).
The chance that a student will guess the correct answer to any one of the questions is 50%
- i. Draw a tree diagram that indicates all possible outcomes for the test. **1**
 - ii. Tzi guesses the answers to all four questions. What is the probability that he will get four correct? **1**
 - iii. What is the most likely mark for Tzi on this test? Explain your answer. **2**
 - iv. Anna answers the first two questions correctly, and guesses the answers to the last two questions. What is the probability that she will get four correct? **1**
- b) In a game called DOTTO a person is required to guess 6 numbers from 35 different numbers.
- i. How many possible combinations of 6 numbers could be selected in a game? **1**
 - ii. What is your chance of winning if you play the game once? **1**
 - iii. Does your chance increase, decrease or remain the same if you play the game once each week for a whole year? Justify your answer. **2**

Question 26 (continued)**Marks**

- c) The two way table shows the results of a new test to detect a disease.
A group of people were selected at random to be given the test.

	Disease detected	Disease not detected	Total
Infected	46	5	51
Not infected	?	97	106
Total	55	102	

- i. What is the value “?” in the table? **1**
- ii. How many people were tested in the trial? **1**
- iii. What percentage of the people infected were detected by the test? **1**
- iv. If the test detected the disease, what is the probability that
The people actually had the disease? **1**

End of Question 26

START A NEW PAGE

Question 27 (13 marks)

Marks

- a. When prescribing medicine to infants, the dosage (D) is given by a formula.

The recommended adult dosage is 12mL.

Jessica is 3 years old and weighs 14kg.

- i. Using Fried's Rule , the dosage (D) can be calculated by the formula:

$$D = \frac{mA}{150} \quad \text{Where A is the adult dosage, m is the infant's age in months.}$$

Calculate the dosage for Jessica.

1

- ii. Using Young's Rule, The dosage (D) can be calculated by the formula:

$$D = \frac{yA}{y+12} \quad \text{Where A is the adult dosage, y is the infant's age in years.}$$

Calculate the dosage for Jessica.

1

- iii. Using Clarke's Rule, the dosage (D) can be calculated by the formula:

$$D = \frac{kA}{70} \quad \text{Where A is the adult dosage, k is the weight of the infant in kg,}$$

Calculate the dosage for Jessica.

1

- iv. If you needed to medicate Jessica what dose would you give and why?

1

- v. Using Fried's Rule, Jasper is given 4mL of the same medicine as Jessica.
How many months old is Jasper?

1

- b. Moscow has coordinates (55°N,38°E) and Copenhagen is at (55°N,12°E)

- i. Use the formula $r = R\cos\theta$ to calculate the radius of the small circle passing through both cities to 2 significant figures.

2

r is the radius of the small circle

R is the radius of the Earth (6400km)

θ is the degree of the small circle

- ii. Find the distance between these cities to the nearest hundred kilometres.

2

Question 27 (continued)**Marks****c.**

- i.** The number of bacteria in a culture grows from 200 to 252 in one hour.
What is the percentage increase in the number of bacteria? **1**

- ii.** The bacteria continue to grow according to the formula

$$n = 200(1.26)^t$$

Where n is the number of bacteria after t hours.

What is the number of bacteria after 5 hours? **1**

- iii.** Using trial and error or otherwise, estimate the time in hours
to 1 decimal place for the number of bacteria to reach 300. **2**

End of Question 27

START A NEW PAGE

Question 28 (13 marks)

Marks

- a) Two ropes are attached to the top of a pole CD, with the other ends tied to two pegs A and B which are 5 metres apart. The ropes make angles of 50° and 35° with the horizontal ground, as shown in the diagram.

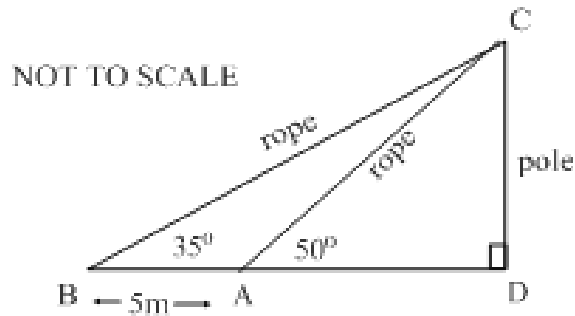

- i. Determine the size of $\angle ACB$. 1
 - ii. By using the sine rule, calculate the length of the rope AC to 1 decimal place. 2
 - iii. Find the height of the pole CD to the nearest 50 centimetres. 2
- b) The storage shed below is constructed on an $8\text{m} \times 8\text{m}$ concrete slab. The roof is 6m above the concrete slab at its highest point and overhangs the walls of the shed by 500mm. The walls of the storage shed are rectangular, each with a dimension of $8\text{m} \times 3\text{m}$.

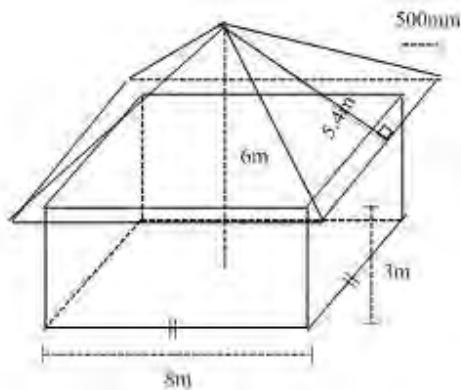

- i. The lengths of the walls are 8m, what is the length of the roof? 1
- ii. The plan of this storage shed has a scale of 1:250. What would be the length of the walls on the plan? (in mm) 1
- iii. Calculate the total surface area of the triangular roof panels. 2

Question 28 (continued)

Marks

- iv. The area of over hang between the roof and the walls is known as the eaves. If the eaves are to be given two coats of paint at a cost of \$6.50 per square metre, how much would it cost to paint the eaves? **3**
- v. Calculate the volume of the roof to 1 decimal place. **1**

End of paper

H.S.C Trials 2008 Solutions

Multiple Choice

- | | | | | |
|------|-------|-------|-------|-------|
| 1. A | 6. C | 11. B | 16. C | 21. C |
| 2. B | 7. D | 12. D | 17. D | 22. A |
| 3. A | 8. C | 13. C | 18. A | |
| 4. A | 9. B | 14. C | 19. B | |
| 5. B | 10. D | 15. D | 20. D | |

Question 23

- (a) (i) $A = \pi \times 6 \times 9 = 170 \text{ cm}^2$ (ii) Area of Circle = $\pi \times 6^2 = 113 \text{ cm}^2$
Unshaded = $170 - 113 = 57 \text{ cm}^2$
- (b) (i) $(360 - 293) + 20 = 87^\circ$ (ii) $AD^2 = 29^2 + 55^2 - 2 \times 29 \times 55 \times \cos$
(iii) Area = $\frac{1}{2} \times 29 \times 38 \times \sin(293 - 27)$
 $= 396 \text{ m}^2$
 $AD^2 = 3699 \quad AD = 60.8 \text{ cm}$
- (c) (i) 29 minutes (ii) 11, 12 or 13 (iii) $\bar{x} = 16.6 \quad \sigma = 7.8$

Question 24

- (a) (i) 45 kg (ii) 28 kg (iii) 6 (iv) 75%
(v) 1995 - symmetrical median = 28. less spread
2005 - positively skewed median = 29. more spread out.
- (b) (i) 4200 nautical miles (ii) $17\frac{1}{2}$ hours
(iii) 1pm Tuesday (iv) 8.40pm Wednesday.

Question 25

- (a) (i) -2 (ii) -0.64 Mathematics because z score is higher
(iii) A(44, 50) (iv) connect AB, mark $\frac{1}{3}$ distance toward C
draw the line keeping gradient the same as AB.
(v) Mathematics = 32 (vi) correlation must be between -1 &
Data is positive, not negative.
- (b) (i) 175 m^2 (ii) $126000 \text{ m}^3 = 1.26 \times 10^8 \text{ Litres}$.

Question 26

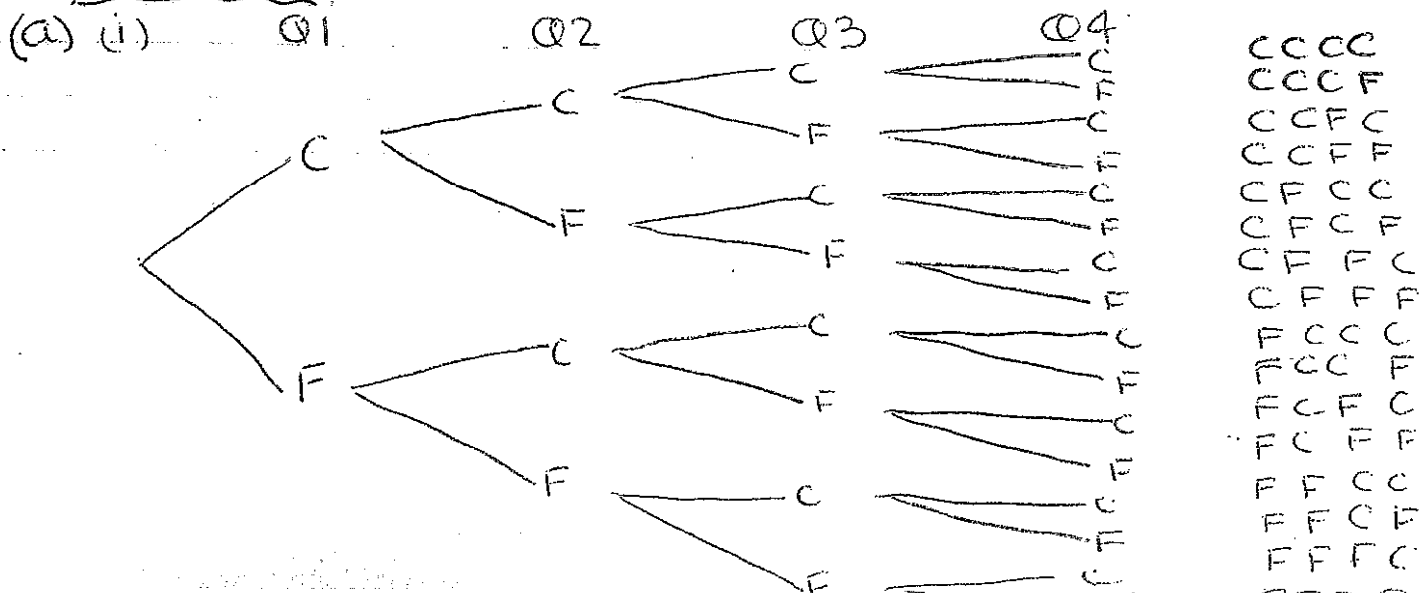

Q26 (a) (ii) $\frac{1}{16}$ (iii) Tzi is more likely to score 2 out of 4 because he has $\frac{1}{16}$ chance all correct/with $\frac{4}{16}$ chance 3 & 1 correct. and $\frac{6}{16}$ chance of scoring 2 correct.

(iv) $1 \times 1 \times \frac{1}{2} \times \frac{1}{2} = \frac{1}{4}$, 25%, 0.25

(b) (i) ${}_{35}C_6$ (ii) $\frac{1}{1623160}$ (iii) Same chance per game.

(c) (i) 9 (ii) 157 (iii) 90% (iv) 84%

Q27 (a) (i) 2.88m/s (ii) 2.4m/s (iii) 2.4m/s

(iv) Dosage & relevant reason.

(v) 50 months

(b) (i) $r = 3700$ km (ii) 1700 km

(c) (i) 36% (ii) 635 (iii) $t = 1.7$ $n = 296$

$t = 1.8$ $n = 303$

$t = 1.75$ $n = 299$

$\therefore n = 1.8$

Q28 (a) (i) $\angle BCD = 55^\circ$ $\angle ACD = 40^\circ$ $\therefore \angle ACB = 15^\circ$

(ii) $AC = \frac{5}{\sin 15} \times \sin 35 = 11.1$

(iii) $CD = 11.1 \sin 50 = 8.5$ m

(b) (i) 9m (ii) 32mm (iii) 97.2 m²

(iv) Area = 17 m² Cost = \$221

(v) Volume = 81 m³