

JAMES RUSE AGRICULTURAL HIGH SCHOOL

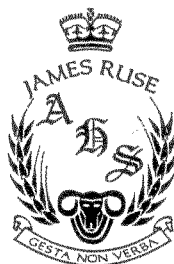

PHYSICS

2001 HIGHER SCHOOL CERTIFICATE

TRIAL EXAMINATION

General Instructions

- Reading time – 5 minutes
- Working time – 3 hours
- Broad-approved calculators may be used
- Draw diagrams using pencil
- A Data and Formulae sheet and a Periodic Table are provided at the back of this paper.
- Write using blue or black pen.

Examination structure

Section 1 Pages 3-18 Total marks 75
This section has two parts, Part A and Part B

Part A Total marks (15)
Attempt Questions 1 - 15
Allow about 30 minutes for this part

Part B Total marks (60)
Attempt Questions 16 - 30
Allow about 1 hour and 45 minutes for this part

Section 11 Pages 19– 20
Allow about 45 minutes for this section.

Section 1

Total marks 75

Part A

Total marks 15

Attempt questions 1 – 15

Allow about 30 minutes for this part.

Use the multiple-choice answer sheet.

Select the alternative A, B, C, or D that best answers the question. Fill in the response oval completely.

Sample $2 + 4 =$ (A) 2 (B) 6 (C) 8 (D) 9

A B C D

If you think you have made a mistake, put a cross through the incorrect answer and fill in the new answer.

A B C D

If you change your mind and have crossed out what you consider to be the correct answer, then indicate this by writing the word correct and draw an arrow as follows:

A B C D

correct →

1. Work is done to move an object of mass m_2 from R_1 to R_2 in a gravity field (g) of planet of mass m_1 .



Which of the following describes the amount of work done?

- (A) $m_2 g R_2 - m_2 g R_1$
- (B) $m_2 g R_1 - m_2 g R_2$
- (C) $\frac{Gm_1 m_2}{R_2} - \frac{Gm_1 m_2}{R_1}$
- (D) $\frac{Gm_1 m_2}{R_1} - \frac{Gm_1 m_2}{R_2}$
2. Just after launch an astronaut experiences an acceleration of $5g$. Two weeks earlier, at a fun park, the astronaut went around a 10 m horizontal bend at 72 kmh^{-1} in a roller coaster. What is the ratio of the rocket launch acceleration to the acceleration at the fun park?
- (A) $5 : [(72)^2 \div 10]$
- (B) $5 : 4$
- (C) $5\text{ g} : [(72)^2 \div 10]$
- (D) $5\text{ g} : 4$
3. A moving spaceship appears to an observer to be 95 m long. It is “actually” 115 m long. Which relationship can be used to determine the speed (v) at which the spaceship is travelling?
- (A) $v = c \left(1 - \frac{95}{115}\right)$
- (B) $v = c \left(1 + \frac{95}{115}\right)$
- (C) $v^2 = c^2 \left(\frac{95^2}{115^2} - 1\right)$
- (D) $v^2 = c^2 \left(1 - \frac{95^2}{115^2}\right)$

4. On a certain planet at a particular time in its flight, the horizontal velocity of a projectile was 50 ms^{-1} and the vertical velocity was 10 ms^{-1} . What is the speed of the projectile at this time?
- (A) 60 ms^{-1}
- (B) $50^2 + 10^2 \text{ ms}^{-1}$
- (C) $(50^2 + 10^2)^{1/2} \text{ ms}^{-1}$
- (D) impossible to determine without being given the value of the planets acceleration due to gravity.
5. An observer in a closed laboratory wishes to determine whether the laboratory is at rest or in motion at constant velocity. Which of the following is correct?
- (A) He can find out by measuring the apparent velocity of light in the laboratory.
- (B) He can find out by measuring his mass.
- (C) He can find out by comparing two different clocks in the laboratory over a period of time.
- (D) He cannot find out.
6. Two flat horizontal coils are mounted as shown. M is a sensitive current meter.

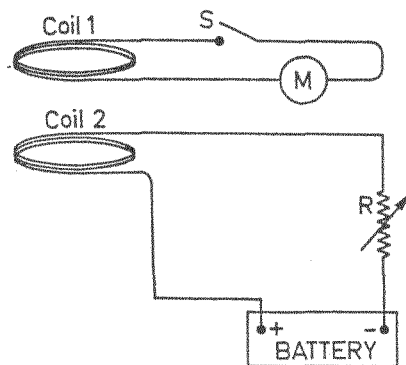

Which of the following actions will not cause the meter M to register a current?

- (A) Coil 2 stationary and coil 1 moving upwards with S kept closed.
- (B) Both coils stationary and S switched on and off.
- (C) Coil 1 stationary with S closed and coil 2 moving to the right.
- (D) With S closed, a variable resistance R is increased and decreased rapidly.

7. The primary winding of a transformer has ~~200~~ turns and its secondary winding has ~~500~~ turns. The current in the secondary winding is 40 A .

What is the current in the primary winding?

- (A) 10 A
- (B) 80 A
- (C) 160 A
- (D) 8000 A

8. Lenz's law is a consequence of the law of conservation of another quantity.

What is this other quantity?

- (A) Charge
- (B) Momentum
- (C) Lines of force
- (D) Energy

9. A sheet of paper coated uniformly with a conducting material is placed on a board and connected to a battery by means of two flat copper plates which make good electrical contact with the paper.

Between which two points is there no potential difference?

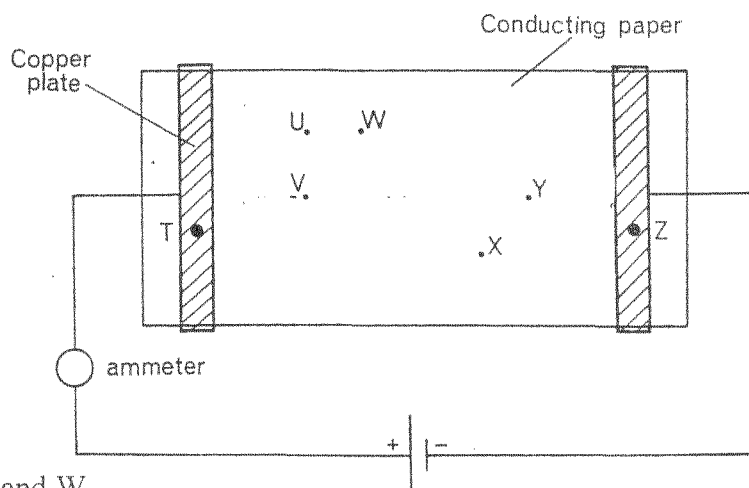

- (A) U and W
- (B) V and Y
- (C) W and X
- (D) U and V

10. What type of crystal has its upper energy band partly occupied by electrons?
- (A) Conductors
 (B) Insulators
 (C) *n*- type semi-conductors
 (D) *p*- type semiconductors
11. A metal plate is pulled out of a magnetic field as shown in the diagram.

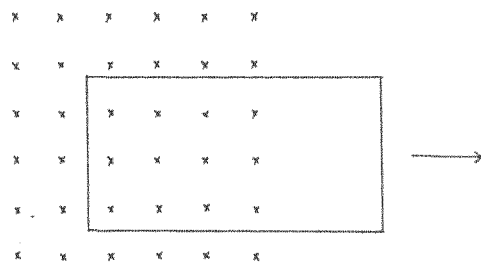

How will the eddy currents flow in the metal plate when it is in the position shown?

- A.
- B.
- C.
- D.

12. When light strikes a metal surface, photoelectric emission may occur. Monochromatic light, of fixed frequency 12×10^{14} Hz, but variable intensity, is shone on to a magnesium surface.

Which of the following graphs best shows the relationship between E_{\max} (the maximum KE of individual electrons) and intensity?

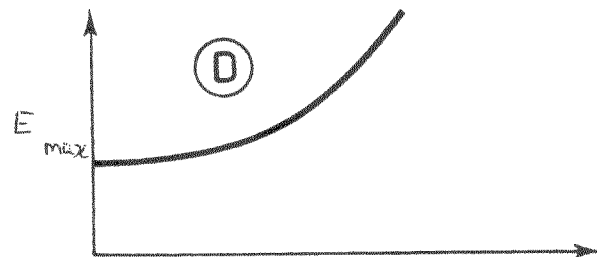
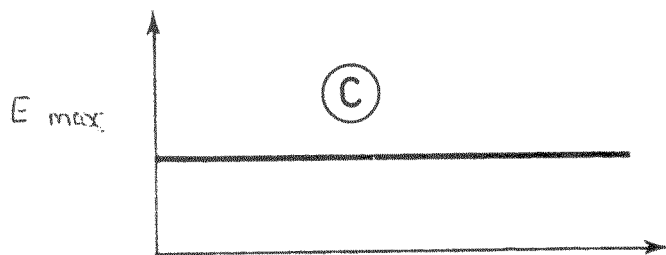
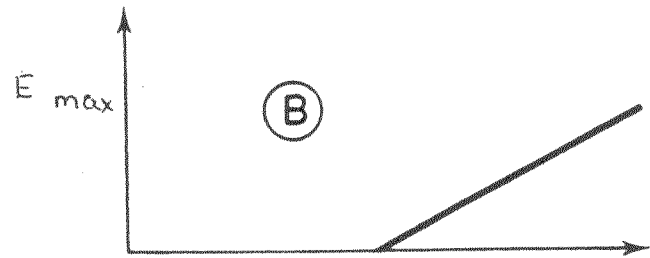
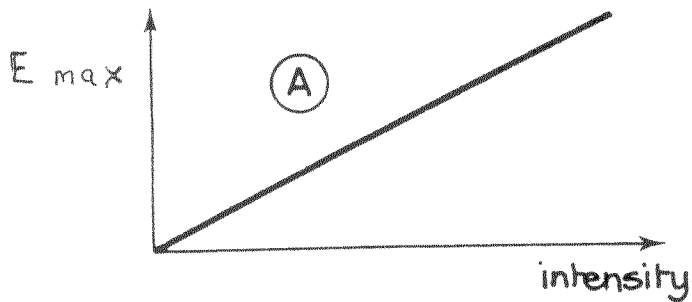

13. The conductivity of a semi-conductor can be greatly enhanced by the process called doping.

Which of the following statements is correct about an *n-type* doped semiconductor?

- (A) Electrons are majority carriers and holes are minority carriers.
- (B) Electrons are minority carriers and holes are majority carriers.
- (C) Current flows more easily one way than another.
- (D) A trivalent impurity atom is used for doping.

14. The diagram represents a loud speaker essentially consisting of a cardboard cone attached to a coil in a magnetic field. When a current flows through the coil, the coil and attached cone move.

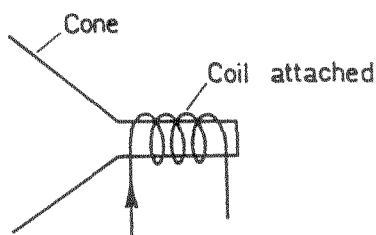

The diagrams below are views of the coil as seen looking into the cone (from the left).

The current is flowing clockwise as shown when viewed from the left side.

Magnetic fields are also shown in the diagrams.

- represents field pointing out of page.
- + represents field pointing into page.

Which diagram shows the magnetic field produced by the current flowing in the coil?

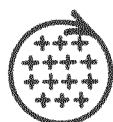

(A)

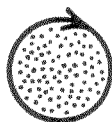

(B)

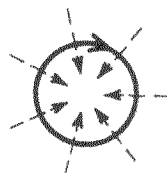

(C)

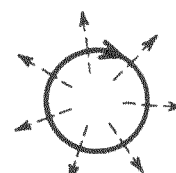

(D)

15. Which of the following is a correct statement identifying Planck's hypothesis?

- (A) Radiation emitted by the walls of a cavity is quantised.
- (B) Charged plates produce an electric field.
- (C) Electrons have wave properties
- (D) Energy is not spread out evenly over a wavefront, but is concentrated in tiny particles or photons.

Student Number

Answer Sheet
Section I
Part A

- | | | | | |
|-----|---|---|---|---|
| 1. | A | B | C | D |
| 2. | A | B | C | D |
| 3. | A | B | C | D |
| 4. | A | B | C | D |
| 5. | A | B | C | D |
| 6. | A | B | C | D |
| 7. | A | B | C | D |
| 8. | A | B | C | D |
| 9. | A | B | C | D |
| 10. | A | B | C | D |
| 11. | A | B | C | D |
| 12. | A | B | C | D |
| 13. | A | B | C | D |
| 14. | A | B | C | D |
| 15. | A | B | C | D |

SECTION B.

Student number:

Total marks 60

Attempt Questions 16 – 30

Allow about 1 hour and 45 minutes for this part.

Answer questions in the spaces provided.

Show all relevant working in questions that require calculations.

Marks

Question 16 (4 marks)

Projectile motion near the Earth’s surface can be analysed by considering velocity components of the motion.

- a) Which velocity component is changing during the flight of the projectile? 2
Explain why this component is changing.

.....
.....
.....
.....
.....
.....
.....

- b) Which velocity component is constant? 2
Explain why this component is constant.

.....
.....
.....
.....
.....

Question 17 (6 marks)

Marks

A communications satellite is orbiting the earth as shown in the diagram.

- (a) Draw and label any forces on the satellite. 2

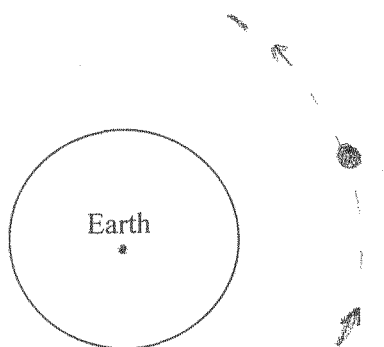

- (b) If the satellite is distant one earth-radius from the surface of the earth calculate the speed at which the satellite will be moving. 2
Radius of the earth = 6400 km. Answer to two significant figures.

.....
.....
.....
.....
.....

- (c) Given that the period of the moon is 30 days and it is 70 earth radii from the centre of the earth, calculate the period (in days) of the satellite in (b) to two significant figures. 2

.....
.....
.....

Question 18 (4 marks)

Marks

A square loop of wire with 25 cm sides is placed in a uniform magnetic field of intensity 0.5 T. A current of 2 A flows through the loop from a constant voltage source.

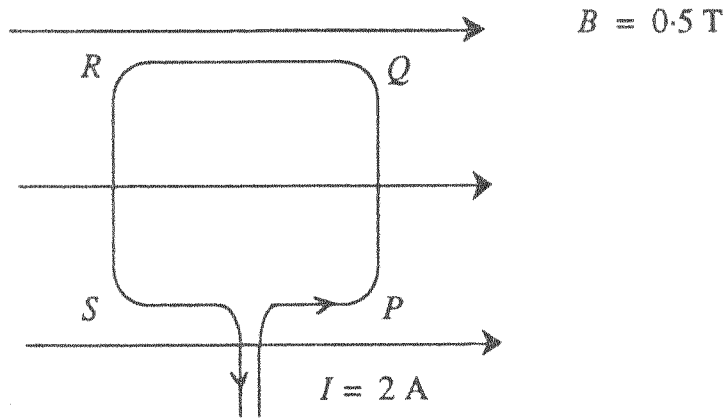

- (a) Calculate the force on the side PQ . 1

.....
.....

- (b) Calculate the maximum torque on the loop due to the field. 2

.....
.....
.....

- (c) The current flow through the loop is observed to decrease at the instant the loop begins to move. 1
Explain why this occurs.

.....
.....
.....

Questions 19 (2 Marks)

Marks

Given: Acceleration due to gravity on Jupiter = 24.8 ms^{-2}

Consider an object of 3 kg mass on Earth and another object of 12 kg mass on Jupiter.

(a) What is the ratio of the masses on Jupiter and Earth? 1

.....

(b) What is the ratio of the forces experienced by those masses on Jupiter and Earth? 1

.....

.....

Question 20 (3 Marks)

Describe the significance of the Michelson-Morley experiment.

.....

.....

.....

.....

.....

.....

Question 21 (2 Marks)

Briefly explain the contribution to rocketry of ONE of the following pioneers:

Tsiolkovsky OR Goddard OR Oberth

.....

.....

.....

.....

.....

Question 22 (3 Marks)

Marks

Assume planet Erus is in a solar system 5 light years from our own. Current space vehicle velocities are about $20,000 \text{ kmh}^{-1}$.

Is it likely that Erus could be visited by earth people in the near future?
Justify your answer with a numerical argument.

.....

.....

.....

.....

.....

.....

Question 23 (4 marks)

Major losses of electrical energy occur in transmission lines.

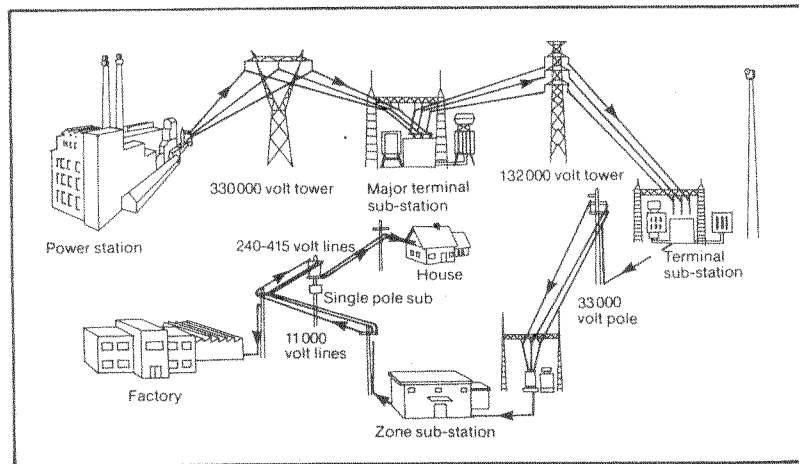

(a) Discuss the energy losses that occur as energy is fed through transmission lines from the generator to the consumer.

2

.....

.....

.....

.....

.....

Question 24 continued on next page

- (b) A transmission line has a total resistance of 200 ohms and is carrying a current of 100 A. Calculate the power lost from this line. 1

.....

.....

- (c) Describe how transmission lines are protected from lightning strikes. 1

.....

.....

Question 24 (7 marks)

Induction motors are called induction motors because of the relative motion of magnetic fields and electrical conductors induces e.m.f. and currents in the conductors.

An induction motor is made up of two main parts, the rotor and stator.

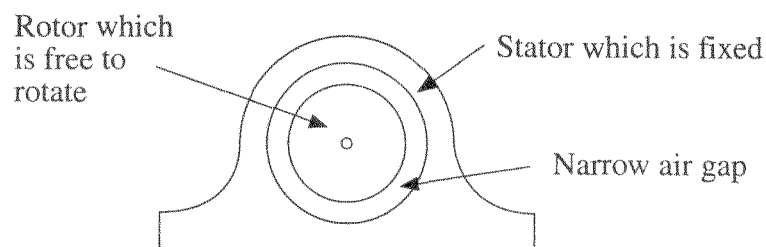

When connected to an ac supply, the stator generates a magnetic field (B) that rotates the air gap with constant speed (v).

The rotor has conducting bars and at the end of the rotor the bars are electrically connected to each other.

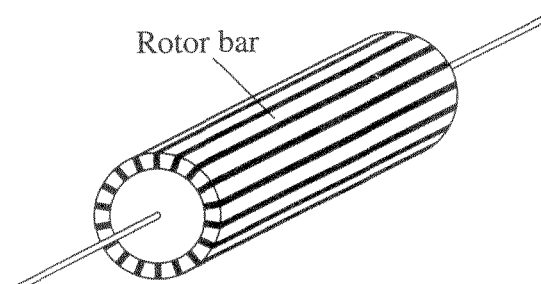

(a) Explain what causes the rotor to turn.

2

.....

.....

.....

.....

.....

.....

(b) List the main advantages of induction motors.

3

.....

.....

.....

(c) Suppose that two adjacent rotor bars are each carrying a current of 120 A in the same direction, that their centres are 15 mm apart, and that they are 20 cm long.

2

Estimate the force exerted by one bar on the other. Will it be attractive or repulsive?

.....

.....

.....

.....

.....

Question 25 (6 Marks)

(a) What is a simple experimental procedure that can distinguish between a gamma ray whose wavelength is 10^{-11} m and an electron whose De Broglie wavelength is also 10^{-11} m? 1

.....

.....

(b) An X-ray photon has a wavelength of 2×10^{-11} m. Marks

(i) Calculate its energy. 2

.....
.....

(ii) Calculate its momentum. 1

.....
.....

(c) Describe how Einstein used the photon model to explain the effect of frequency on photocurrent. 2

.....
.....
.....
.....

Question 26 (6 Marks)

Metals are sometimes compared according to their 'drift velocity'.

(a) Define 'drift velocity' 1

.....
.....

(b) List and discuss three factors that affect drift velocity. 3

.....
.....
.....
.....
.....

(c) Describe a model of metal structure that explains the good conductivity of metals.

2

.....

.....

.....

.....

Question 27 (4 marks)

(a) Draw a neat labelled diagram showing the essential components of a DC electric motor.

3

(b) Compare the function of a generator to an electric motor.

1

.....

.....

Question 28 (4 marks)

(a) Explain why a magnet is able to hover above a semi-conducting material that has reached the temperature at which it is super-conducting?

2

.....

.....

.....

.....

.....

- (b) Compare the behaviour of electrons that flow in a metal at room temperature with the electrons that flow in a superconductor below its critical temperature. 2

.....

.....

.....

.....

.....

Question 29 (5 marks)

Discuss how shortcomings in available technology led to an increased knowledge of the properties of materials with particular reference to the invention of the transistor. Include in your discussion why solid-state devices replaced thermionic devices.

.....

.....

.....

.....

.....

.....

.....

.....

.....

.....

.....

.....

.....

.....

Section II

Allow about 45 minutes for this section.
Answer this question in a writing booklet.

Question 30 – Quanta to Quarks (25 marks)

Marks

- (a) In 1913 Niels Bohr proposed a new model for the atom. He based his model on a number of assumptions.
- (i) Define Bohr's postulates. 3
 - (ii) Discuss the limitations of the Bohr atomic model. 4
- (b) (i) Explain the stability of the electron orbits in the Bohr atom using De Broglie's hypothesis. Include a diagram in your answer. 2
- (ii) Calculate the De Broglie wavelength for an electron moving at 90% of the speed of light. 2
- (c) The electron microscope is an important application of the electron waves. The Scanning Electron Microscope image below shows zinc oxide vapour deposited on the Olympic torch.

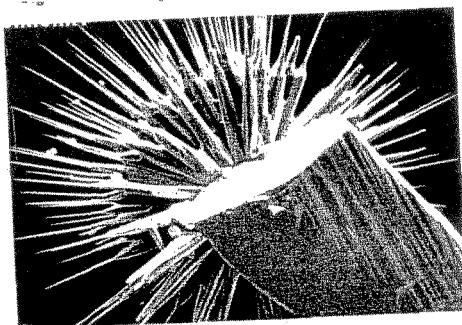

- Explain how the magnetic lenses in an electron microscope build such a picture. 3

Question 30 continued on next page

- (d) The nucleus ${}_{90}^{233}\text{Th}$ undergoes two negative beta decays in becoming an isotope of Uranium. What is the symbol of the Uranium isotope?
(Use complete notation) 1
- (e) The mass of ${}_{10}^{20}\text{Ne}$ is 19.99244 amu. 3
- i. Calculate the mass defect.
 - ii. Calculate its binding energy.
 - iii. Calculate its binding energy per nucleon.
- (f) Isotopes have been used widely in the agricultural and engineering industry. 4
For EACH of the industries listed above,
- (i) name a specific isotope that is used in the named industry;
 - (ii) describe how each isotope is used.
- (g) List the properties of the strong nuclear force. 3

End of question 30