

JAMES RUSE AGRICULTURAL HIGH SCHOOL

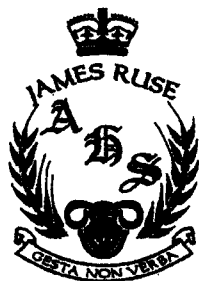

2002

HIGHER SCHOOL CERTIFICATE

TRIAL EXAMINATION

Physics

General Instructions:

- Reading time – 5 minutes
- Working time – 3 hours
- Write using black or blue pen
- Draw diagrams using pencil
- Board-approved calculators may be used
- A data sheet, formulae sheets and Periodic Table are provided at the back of this paper
- Write your Student Number at the top of pages as indicated.

Total marks - 100

Section I Pages 2 - 18

75 marks

This section has two parts, Part A and Part B

Part A – 15 marks

* Attempt Questions 1 – 15

* Allow about 30 minutes for this part

Part B – 60 marks

* Attempt Questions 16 – 27

* Allow about 1 hour and 45 minutes for
for this part

Section II Pages 21 – 23

25 marks

* Attempt Question 28

* Allow about 45 minutes for this section

- During a visit to the Moon an astronaut throws a rock vertically and it reaches a height of 20.0 m. Acceleration due to gravity on moon is 1.6 ms^{-2} .
What is the speed at which it was thrown on the moon?
 - 25.3 ms^{-1}
 - 62.6 ms^{-1}
 - 640 ms^{-1}
 - 3920 ms^{-1}
- What is the de Broglie wavelength of an electron whose speed is half of the speed of light?
 - $3.6 \times 10^{-12} \text{ m}$
 - $4.4 \times 10^{-11} \text{ m}$
 - $4.9 \times 10^{-12} \text{ m}$
 - $1.2 \times 10^{-11} \text{ m}$
- When the speed of a DC motor drops because of an increased load, there is also a drop in one other quantity. Which quantity also decreases?
 - battery voltage
 - current
 - back emf
 - armature resistance
- A rocket is to be launched to arrive at its destination, X. The relative positions of the Earth, Sun and X are shown in the diagram (not drawn to scale).

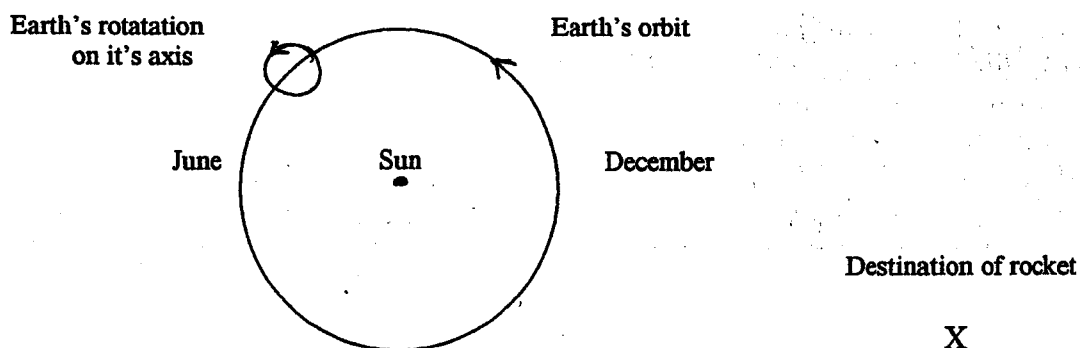

What is the best time for launching the rocket to take advantage of the Earth's motion in space?

- September at midnight
- September at midday
- November at midnight
- November at midday

5. An atom emits a photon when one of its electrons is in a particular situation. Which situation will this be?
- Electron collides with another electron
 - Electron exchanges quantum states with another of its electrons
 - Electron undergoes a transition to a quantum state of lower energy
 - Electron undergoes a transition to a quantum state of higher energy.
6. A 100% efficient transformer has 100 turns in its primary winding and 300 turns in its secondary. If the power input to the transformer is 60 W, the power output is
- 20 W
 - 60 W
 - 180 W
 - 540 W
7. A battery voltage is applied across two parallel conducting plates, d_0 and d_1 . The battery voltage is removed without discharging the plates.

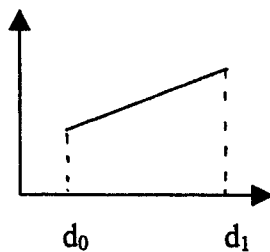
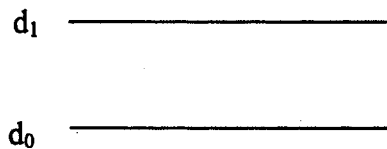

x

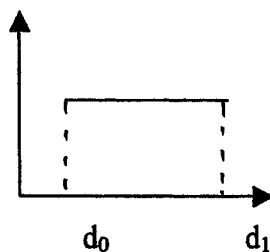

y

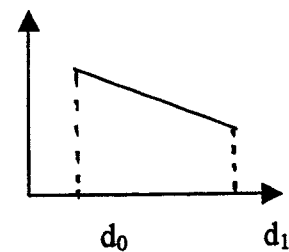

z

Which graphs best describe the variation in voltage difference between the plates and electric field between the plates?

	voltage difference	electric field
(a)	x	y
(b)	y	x
(c)	z	y
(d)	x	z

8. "It is not possible to detect uniform velocity motion while within a frame of reference without referring to another frame". Which principle correctly describes this statement?
- The principle of constancy of velocity
 - The principle of uncertainty
 - The principle of relativity
 - The exclusion principle
9. A metal ring is passed with a constant velocity v through a rectangular region enclosing a magnetic field as shown in the following diagram, beginning at W and ending at Z.

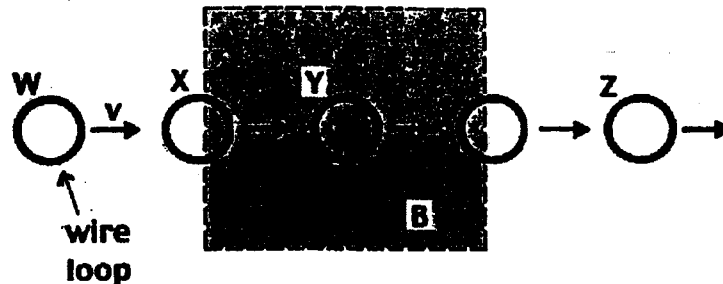

A current flows around the coil when it is in the labelled positions

- W, X, Y and Z
 - X and Y only
 - Y only
 - X only
10. In the construction of high power transmission lines which of the following is not a necessary precaution?
- Insulating the wires from supporting structures
 - Protecting the main wires from lightning strikes
 - Separating the wires by a minimum safe distance
 - Keeping the current in adjacent wires out of phase
11. Which of the following orbits is most likely to suffer from orbital decay?
- high-altitude circular orbit
 - low-altitude elliptical orbit
 - mid-altitude polar orbit
 - geostationary orbit

12. A wire 20 m long passes through the ceiling of a building carrying a direct current of 20 A from east to west. Considering the horizontal component of the earth's magnetic field at this point is 2×10^{-5} T, what is the magnitude of the magnetic force acting on the wire?



- (a) 8×10^{-3} N
(b) 2×10^{-5} N
(c) 4×10^{-3} N
(d) 1×10^{-5} N
13. An electron follows a circular path in a uniform magnetic field of strength 2.7×10^{-2} T. The speed of the electron is 5.3×10^7 ms⁻¹. After 2 complete orbits how much energy does the electron gain?
- (a) 0 J
(b) 1.28×10^{-15} J
(c) 1.79×10^{-21} J
(d) 1.43×10^6 J
14. Which statement is correct about Planck's hypothesis regarding the photoelectric effect?
- (a) Radio waves are created at a right angle to the gap in an induction coil.
(b) The charge to mass ratio of an electron is quantised.
(c) Radiation absorbed and emitted by the walls of a black body cavity is quantised.
(d) Electrons without enough kinetic energy to cross a gap in an induction coil can do so when light is incident upon the electrons.
15. The gravitational potential energy (GPE) of a mass m at a point R from a mass M is $-J$ joules. What is the ratio of the GPE of m when it is $\frac{R}{3}$ from M compared with when it is at $4R$ from M ?
- (a) $-12 : 1$
(b) $12 : 1$
(c) $3 : 1$
(d) 4

Section I (continued)

Part B – 60 marks

Attempt Questions 16 to 27

Allow about 1 hour and 45 minutes for this part.

Answer the questions in the spaces provided.

Show all relevant working in questions involving calculation.

Question 16 (2 marks)

Marks

A geostationary satellite is placed at a distance of about 36000 km from the centre of the Earth. Calculate the period (in days) of a satellite placed at 72000 km from the centre of the Earth.

Question 17 (5 marks)

Marks

Solar cells make use of the photoelectric effect.

Describe the construction of a typical solar cell, and explain how it is able to produce a photocurrent. Use a labelled diagram to aid your answer.

Question 18 (6 marks)

Marks

To reach the most distant planets such as Saturn and Uranus space probes require very great speeds. These space probes make use of the slingshot or gravity-assist effect.

(a) Explain how this slingshot effect works.

3

(b) Indicate where the extra energy comes from that allows the probe to leave the assisting planet faster than it arrived.

1

(c) Would an observer on that assisting planet agree that the probe's speed has increased? Discuss your reasons.

2

Question 19 (5 marks)

The diagram shows a single – loop generator.

Marks

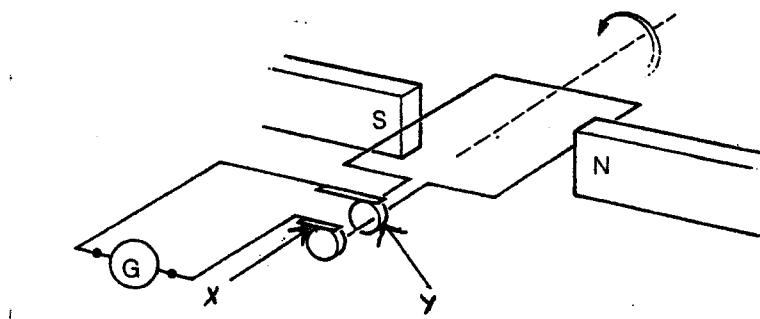

(a) Name the parts.

X _____

Y _____

1

(b) What type of generator is this? Justify your answer.

3

(c) Show on the diagram the directions of the conventional induced current flowing through the galvanometer, G.

1

(d) Draw the voltage/time trace that would be obtained on a CRO from the output of this generator.

1

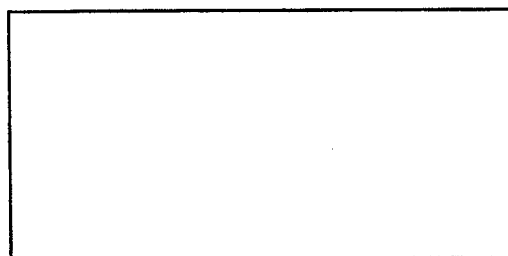

Question 20 (6 marks)

Marks

Thomson carried out an experiment to investigate cathode rays. A simplified drawing of the equipment he used is shown.

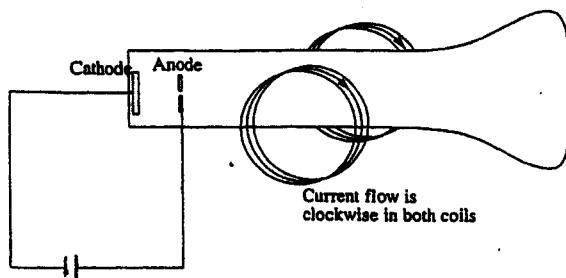

(a) What were the two main conflicting hypotheses about cathode rays that existed before this experiment?

2

(b) Referring to the diagram, in which direction will the cathode rays tend to curve as a result of the current in the coils? (Clearly indicate)

1

(c) Explain why the measurement of the radius of this curve was so important to Thomson's investigation.

2

Question 20 continued on next page

(d) What important discovery was made from the result of this experiment? 1

Question 21 (5 marks)

(a) Describe the nature of sunspot activity and explain how sunspots create problems for satellite communication. 3

(c) Explain why microwaves are preferred over radio waves for space communication. 2

Question 22 (8 marks)

Marks

(a) Outline the nature of an inertial frame of reference.

1

(b) Design an investigation to help distinguish between non-inertial and inertial frames of reference.

3

(c) Explain what results will demonstrate the differences.

2

(d) Indicate how 'reliability' could be improved in your investigation.

2

Question 23 (5 marks)

Marks

(a) Distinguish between 'force' and 'torque'

2

(b) A circular loop of wire with radius 5.0 cm is placed in a magnetic field with strength 0.5 T. A current of 1.5 A flows in the loop.

(i) Calculate the magnitude of maximum and minimum torque acting on the loop.

2

(ii) How would the torque change if the loop was replaced by 50 turns of similar wire with the same radius?

1

Question 24 (6 marks)

Marks

Currents can be carried by both metallic conductors and semi-conductors.

- (a) Describe the structure and properties of a metal that allow it to be a good conductor of electric current.

2

- (b) Describe the factors that influence the drift velocity of electrons through metallic resistors.

3

- (c) As temperatures decrease, how does the resistance to the flow of electrons in good conductors compare with the resistance to the flow of electrons in semi-conductors ?

1

Question 25 (3 marks)

Marks

A beam of monochromatic light falls onto a cold, perfect black body and imparts 0.10 mW of power to it. The wavelength of the light is 5.0×10^{-7} m.

(a) Calculate the frequency of the light.

1

(b) Calculate the energy per photon of the light

1

(c) Calculate the number of photons per second striking the black body.

1

Question 27 (3 marks)

Marks

An electric relay is a device that uses a small current in one circuit to control a large current in another circuit. For example, a large current is needed to start a car, but a small current is provided at the switch S, operated by the driver.

Use the diagram of the relay shown to explain the working of the relay R.

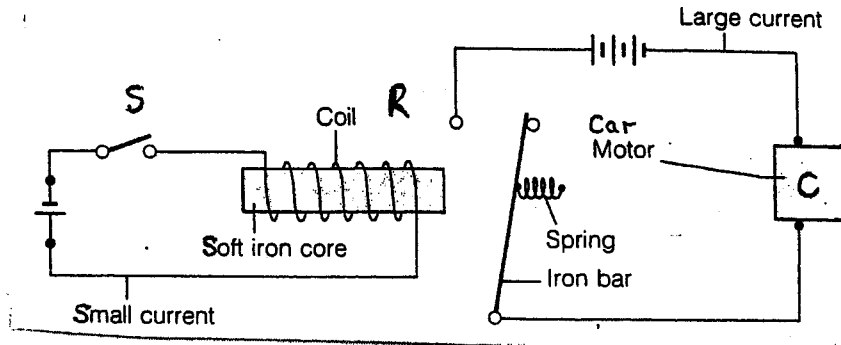

Question 28 – From Quanta To Quarks (25 marks)

Marks

- (a) Describe the similarities and differences between the Bohr and Rutherford models of the hydrogen atom. **2**
- (b) A student performed an investigation to observe the hydrogen spectrum. Describe using a diagram how the student would have set up and used the equipment to make the observations. **2**
- (c) Explain how the Davisson and Germer experiment confirmed de Broglie's proposal about the nature of electrons. **3**
- (d) Between 1934 and 1938 Enrico Fermi and his co-workers bombarded many of the elements with neutrons.
- (i) What were formed as a result of this bombardment? **1**
- (ii) Complete the equations for one of the reactions that Fermi investigated **2**
- $${}_{29}^{65}\text{Cu} + {}_0^1\text{n} \rightarrow ?\text{Cu} \quad \text{then} \quad ?\text{Cu} \rightarrow ?\text{Zn} + {}_{-1}^0\text{e}$$
- (iii) What type of decay does the resulting copper nucleus undergo? **1**

Question 28 continued on next page

(e) The photographs show rabbit sperm cells observed using three different microscopes.

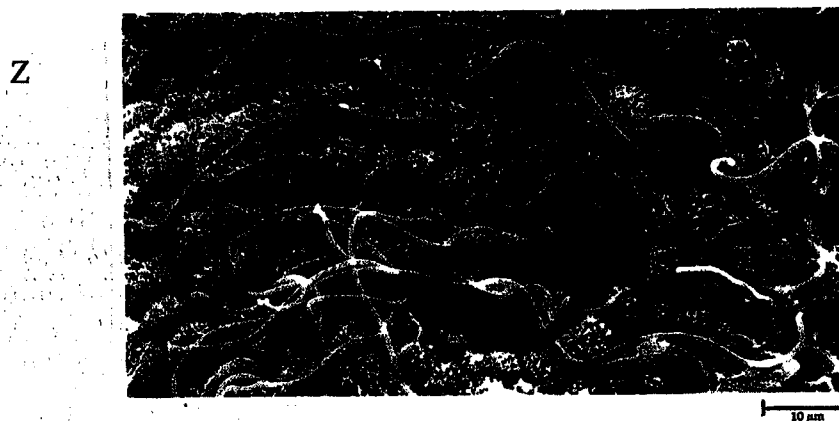
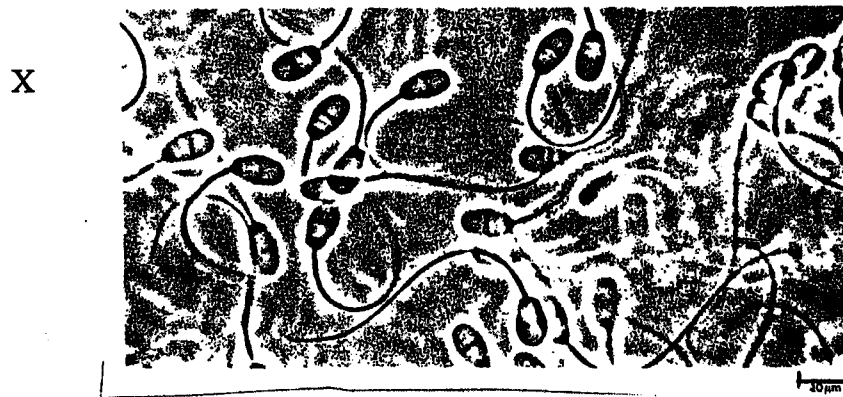

- (i) Identify the type of microscope that would have been used to obtain each of the photographs X, Y and Z. 2
- (ii) Explain why the resolving powers for microscopes X and Y are different. 2

Question 28 continued on next page

(e) A ${}_{92}^{235}\text{U}$ nucleus can undergo fission by this reaction:

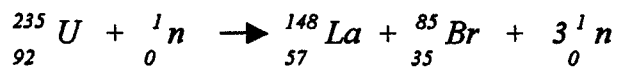

(i) What is the significance of the fact that one neutron fired in, can cause three neutrons to be released? 1

(ii) The rest masses of some quantities are listed: 2

$${}_{92}^{235}\text{U} = 235.124 \text{ u}$$

$${}_{57}^{148}\text{La} = 147.961 \text{ u}$$

$${}_{35}^{85}\text{Br} = 84.938 \text{ u}$$

$${}_0^1\text{n} = 1.0087 \text{ u}$$

Calculate the energy released, in MeV, from the fission of a ${}_{92}^{235}\text{U}$ nucleus undergoing the reaction above.

(f) Discuss the contributions of de Broglie, Heisenberg and Pauli to the development of atomic theory. 7

End of paper

JAMES RUSE AGRICULTURAL HIGH SCHOOL

2002

HIGHER SCHOOL CERTIFICATE

TRIAL EXAMINATION

Physics

Marking Guidelines

1. A	2 C	3 C	4 A	5 C	6 B
7 A	8 C	9 D	10 D	11 B	12 A
13 A	14 C	15 B			

Part B – 60 marks

Attempt Questions 16 to 27

Allow about 1 hour and 45 minutes for this part.

Answer the questions in the spaces provided.

Show all relevant working in questions involving calculation.

Question 16 (2 marks)

Marks

A geostationary satellite is placed at a distance of ~~35~~⁶⁰800 km from Earth's surface. Calculate the period (in days) of a satellite placed at 72000 km from the centre of the Earth. Radius of Earth = 6.38×10^6 m

2

$$\frac{R^3}{T^2} = k \quad \Rightarrow \quad \frac{36000^3 \times 10^3}{1^2} T = 42 \text{ days}$$

Question 17 (5 marks)

Solar cells make use of the photoelectric effect.

Describe the construction of a typical solar cell, and explain how it is able to produce a photocurrent. Use a labelled diagram to aid your answer.

- A solar cell converts radiant energy from the sun directly into electrical energy.
- Light energy is applied to the junction region of a semiconductor (p and n type Si)

- Electrons are released because of the photoelectric effect.
- The electron leaves a hole behind creating an e^- - hole pair.
- The potential barrier causes separation of these pairs, setting up an emf.
- Fine metal grid acts as electrical contacts.

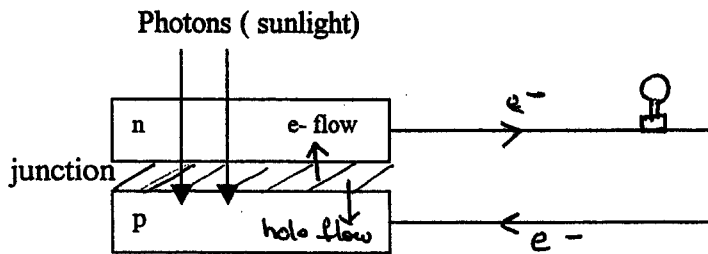

Question 18 (6 marks)

To reach the most distant planets such as Saturn and Uranus space probes require very great speeds. These space probes make use of the slingshot or gravity-assist effect.

(a) Explain how this effect works.

3

As the space probe approaches the planet, it is accelerated by the planet's gravitational attraction, causing it to speed up relative to the planet. As the probe passes the planet, its speed is reduced relative to the planet, however, its speed has increased relative to the sun.

Include diagram showing this effect.



(b) Indicate where the extra energy comes from that allows the probe to leave the assisting planet faster than it arrived.

1

Space probe picks up some of the planet's energy.

(c) Would an observer on that assisting planet agree that the probe's speed has increased? Discuss your reasons.

2

As probe passes planet, its speed is the same relative to the observer on the planet.

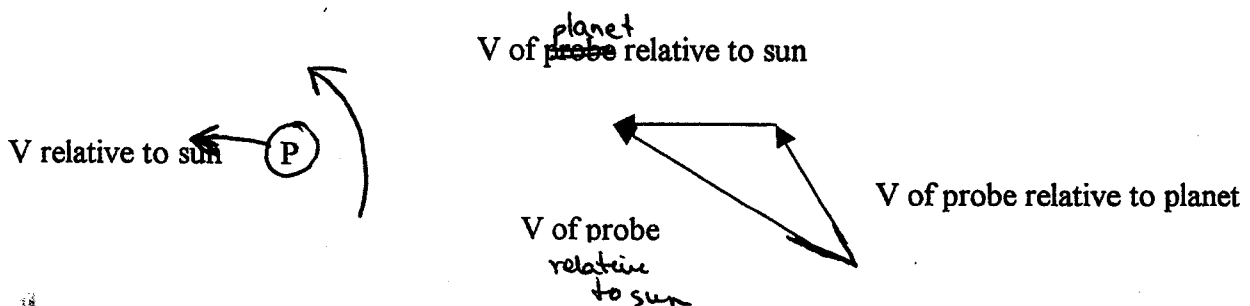

Question 19 (5 marks)

The diagram shows a single – loop generator.

- (a) Name the parts.

X Brush Y Slip ring

- (b) What type of generator is this? Justify your answer. 2

AC generator
Slip rings are connected to the coil at its ends
Brushes make the contact with these slip rings

- (c) Show on the diagram the directions of the conventional induced current flowing through the galvanometer, G. 1

From X to Y in the position shown

- (d) Draw the voltage/time trace that would be obtained on a CRO from the output of this generator. 1

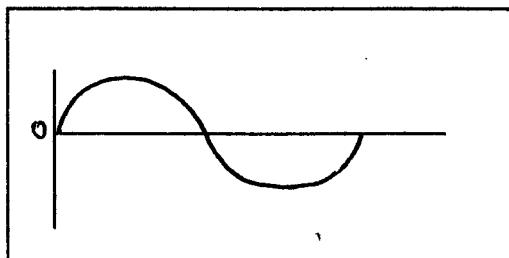

Question 20 (6 marks)

- (a) Thomson carried out an experiment to investigate cathode rays. A simplified drawing of the equipment he used is shown. 2

What were the two main conflicting hypotheses about cathode rays that existed before this experiment?

Are cathode rays particles?

Are cathode rays waves?

- (b) Referring to the diagram, in which direction will the cathode rays tend to curve as a result of the current in the coils? (Clearly indicate) 1

- (c) Explain why the measurement of the radius of this curve was so important to Thompson's investigation. 2

- The charge-mass ratio of the e⁻ was determined
- The two fields were adjusted until cathode rays were moving straight.
- $F_e = F_B$
- He could calculate E and v
- He equated $qvB = \frac{mv^2}{R}$
- He could measure r directly from the tube and then calculate q

$$\frac{q}{m} = \frac{v}{Br} = \frac{E}{B^2 r}$$

Question 21 (5 marks)

- (a) Define the term 'sunspots' and explain how sunspots create problems for satellite communication. 1

Sunspots are regions of stronger magnetic fields and cooler surface temperatures. They appear darker than the surrounding surface and seem to move across the face of the sun. Sunspots cause disruption to communication because emr is affected by magnetic fields.

- (c) Explain why microwaves are preferred over radio waves for space communication. 2

Microwaves have a frequency range 1000 – 300,000 MHz and the shorter wavelengths are more able to penetrate clouds, haze, snow. Smaller spacecraft antennae are required.

Radio waves need to be shared between FM radio stations and radio telescopes (which are very large) and interference can occur.

Question 22 (8 marks)

- (a) Outline the nature of an inertial frame of reference. 1

An inertial frame of reference is a non-accelerating frame of reference

- (b) Design an investigation to help distinguish between non-inertial and inertial frames of reference. 3

Accelerometer on trolley with masses attached or lifts accelerating up or down or rotating turntable.

Very good design must be able to distinguish clearly between the two.

- (c) Explain what results will demonstrate the differences. 2

Clear statement of result for each: inertial frame and non-inertial frame.

- (d) Indicate how reliability could be improved in your investigation. 2

Should be clearly related to the investigation designed.

Question 23 (5 marks)

- (a) Distinguish between 'force' and 'torque' 2

Force: a push or pull

Torque: the turning effect of a force applied at a distance.

- (b) A circular loop of wire with radius 5.0 cm is placed in a magnetic field with strength 0.5 T. A current of 1.5 A flows in the loop. 2

- (i) Calculate the magnitude of maximum and minimum torque acting on the loop.

$$\text{Max torque} = nBIA = 1.03 \times 10^{-2} \text{ Nm}$$

Min torque: zero

- (ii) How would the torque change if the loop was replaced by 50 turns of similar wire with the same radius? 1

$$\text{Increase 50 times (} 5.2 \times 10^{-1} \text{ Nm)}$$

Question 24 (6 marks)

Currents can be carried by both metallic conductors and semi-conductors.

- (a) Describe the structure and properties of a metal that allow it to be a good conductor of electric current. 2

Diagram or description showing cations in a metallic lattice with delocalised electrons.

- (b) Describe the factors that influence the drift velocity of electrons through metallic resistors. 3

Drift velocity of electrons in a conductor carrying constant current is inversely proportional to:

density of electrons, cross-sectional area and electronic charge.

(Description is necessary ~~and~~ just listing)

- (c) At low temperatures how does the resistance to the flow of electrons in good conductors compare with the resistance to the flow of electrons in semi-conductors? 1

In good conductors, resistance decreases with decreasing temperature.

In semi-conductors, resistance increases with decreasing temp.

Question 25 (3 marks)

A beam of monochromatic light falls onto a cold, perfect black body and imparts 0.10 mW of power to it. The wavelength of the light is 5.0×10^{-7} m.

- (a) Calculate the frequency of the light. 1

$$F = \frac{v}{\lambda} = \frac{3 \times 10^8}{5 \times 10^{-7}} = 6 \times 10^{14} \text{ Hz}$$

- (b) Calculate the energy per photon of the light 1

$$E = hf = 6.6 \times 10^{-34} \times 6 \times 10^{14} = 3.96 \times 10^{-19} \text{ J}$$

- (c) Calculate the number of photons per second striking the black body. 1

$$P = \frac{W}{t} \quad \text{No. of photons} = \frac{0.11 \times 10^{-3}}{3.96 \times 10^{-19}} = 2.5 \times 10^{14}$$

Question 26 (6 marks)

The diagram shows an induction motor

- (a) Discuss why it is important to have an electromagnet as opposed to a permanent magnet creating the magnetic field and how this magnetic field causes rotation. 4

Induction motors require AC to induce the current in the rotor. A permanent magnet will not give this ac and therefore a change in magnetic flux. The lag between current and induced ac gives the phase change. This puts the rotor out of phase with the stator. This produces the turning effect.

- (b) Explain why the motor produces a low power and therefore would be unsuitable for use in heavy machinery? 2

Low current is induced in rotor and this will give a low power. Industry requires high power i.e. high current supplied by commutator.

Question 27 (3 marks)

An electric relay is a device that uses a small current in one circuit to control a large current in another circuit. For example, a large current is needed to start a car, but a small current is provided at the switch S, operated by the driver.

Use the diagram of the relay shown to explain the working of the relay R.

Switch closes and current flows through coil. This makes the soft iron core attract the iron bar. Iron bar when attracted, completes the circuit and the car motor will now be supplied with the large emf / current

Question 28 – From Quanta To Quarks (25 marks)

Marks

- (a) Describe the similarities and differences between the Bohr and Rutherford models of the hydrogen atom. 2

QUANTA TO QUARKS

Answer Booklet

Student No.....

a) Rutherford

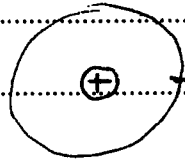

e^- revolving around
+ nucleus

Bohr

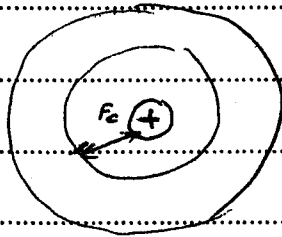

+ nucleus, with e^- orbiting in
stable orbit.
Energy of e^- remained constant
unless it jumped into an

orbit of higher or lower energy.

b)

(discharge)

H spectral tube.

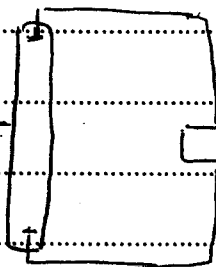

power supply

A H discharge tube
is a CRT containing

H_2 (g)

spectroscope.

Darken the room

Connect H spectral tube to power supply

when switched on, view the

radiation produced through a spectroscope

Observe the colours of the spectral lines

(and record λ)

c) In 1927, Davisson and Germer reported the diffraction of electrons.

Diffraction had been a property unique to waves until then. This was the experimental evidence that de Broglie's hypothesis needed.

Davisson and Germer were studying the reflection of e^- from a Ni target by using a narrow beam of e^- to avoid producing X-rays.

Air accidentally leaked in forming the oxide, which when heated to remove, annealed the Ni, converting it to large crystals. These crystals were larger than the width of their e^- beam.

The results were very different and they recognised that the e^- were being diffracted.

As diffraction is a property of waves, not particles, they had established that e^- had a wave nature as well as a particle nature.

d) (i) isotopes

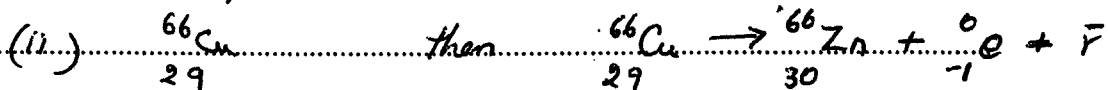

(iii) β decay

- (e) (i) X optical/light microscope
 (ii) Y TEM transmission
 (iii) Z SEM scanning

(ii) X uses light which has a much higher λ (400 - 700 nm) and has a lower resolving power. Resolving power depends on λ .
 Y uses a beam of e^- with a λ of about 10 nm with a resolution of 0.2 nm, almost 1000 times better than light microscope

(f)(i) Can produce a chain reaction which can either be controlled or uncontrolled.

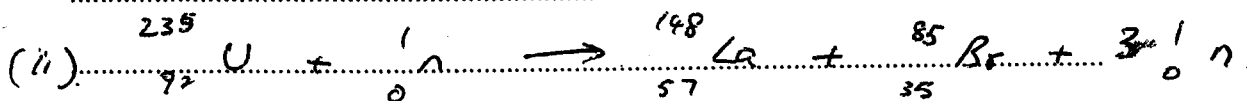

$$235.124 + 1.0087 \rightarrow 147.961 + 84.938 + 3(1.0087)$$

$$236.1327 \quad 235.9251$$

$$\text{mass defect} = 0.2076$$

$$B.E. = 0.2076 \times 931.5 = \boxed{193.4 \text{ MeV}}$$

9) De Broglie

- e^- have wave/particle duality
- $n =$ integral no. of λ
- allowed e^- orbits were those that fitted standing waves in them.

Heisenberg

- momentum and position not simultaneous \times determined accurately
- idea of probability of e^- position
- derived the same equations as de Broglie and Bohr

Pauli

- No two e^- have ^{all four} same quantum no. same
- proposed that each e^- could be distinguished from others by considering their 4 quantum no.
- This explained the arrangement of e^- around atoms in the orbits + suborbits.
- These ideas now explain most physical and chemical properties of matter.

(Overriding statements linking all contributions)